

An Analysis of the Abhidhammatthasaṅgaha

This is a transcription of a series of lectures given by an unknown author. The transcription was found in the library of Chanmay Meditation Centre in Burma by Manfred Wierich of Germany, who digitalized them.

What is presented here only covers the first chapter of the *Abhidhammatthasaṅgaha*; the remaining chapters have not yet been found. If you know who gave these talks and/or where the remaining chapters can be found, then please contact the editor of the Buddhist Publication Society, PO Box 61, Kandy, Sri Lanka.

Charts 1 and 2 are missing.

This document requires more proofreading. If you'd like to help contact the editor of the BPS.

Contents

| | |
|----------------------------------------------------------------------------------|----|
| Chapter One, Consciousness (Citta)..... | 4 |
| Introduction..... | 4 |
| Talk One (Part One)..... | 4 |
| (Talk One: Part Two)..... | 10 |
| Talk Two (Part One)..... | 16 |
| good and Bad (<i>kusala, akusala</i>)..... | 18 |
| Roots (<i>hetū</i>)..... | 19 |
| Greed (<i>lobha</i>)..... | 21 |
| Feeling (<i>vedanā</i>)..... | 22 |
| Talk Two (Part Two)..... | 24 |
| Wrong View (<i>diṭṭhi-gata</i>)..... | 24 |
| Dissociation from Wrong View, Conceit (<i>diṭṭhigatavippayutta, māna</i>)..... | 25 |
| General Characteristic, Etc. (<i>lakkhan adi</i>)..... | 26 |
| General Characteristic (<i>lakkhana</i>)..... | 26 |
| Inherent Functional Property (<i>rasa</i>)..... | 26 |
| Resultant Appearance (<i>paccupajjhāna</i>)..... | 26 |
| Concurrent Footing (<i>padatthāna</i>)..... | 27 |
| Uninstigated, Instigated (<i>asaṅkhārika, saṅkhārika</i>)..... | 27 |
| Factorial Consciousness (<i>citta</i>)..... | 27 |
| Talk Three (Part One)..... | 30 |
| Causality..... | 30 |
| Talk Three (Part Two)..... | 37 |
| Root of Hatred..... | 37 |
| Dullness and Delusion..... | 39 |
| Distraction..... | 41 |
| Causality..... | 42 |
| Talk No. 4 (Part 1)..... | 44 |
| Consciousness, Action and Resultant..... | 44 |
| Talk No. 4 (Part 2)..... | 51 |
| Talk No. 5 (Part 2)..... | 65 |
| Talk No. 6 (Part 1)..... | 71 |
| Talk No. 6 (Part 2)..... | 77 |

| | |
|----------------------------------------------|-----|
| Talk No. 7 (Part 1)..... | 84 |
| Talk No. 7 (Part 2)..... | 92 |
| Sublime Consciousness (Mahāggata Citta)..... | 92 |
| Talk No. 8 (Part 1)..... | 100 |
| Talk No. 8 (Part 2)..... | 107 |
| Talk No. 9 (Part 1)..... | 114 |
| Talk No 9 (Part 2)..... | 121 |
| Talk No. 10 (Part 1)..... | 129 |
| Talk No. 10 (Part 2)..... | 137 |
| Talk No. 11 (Part 1)..... | 146 |
| Talk No. 11 (Part 2)..... | 155 |
| Appendix | 165 |
| the Mango Simile..... | 165 |
| Charts | 167 |

Chapter One, Consciousness (Citta)

Introduction

Talk One (Part One)

1. This is the first of a series of talks in which the aim is to speak of, and to enlarge upon to some extent by way of explanation, the book entitled *Abhidhammatthasaṅgaha*. It is a book which for many hundreds of years has, in Buddhist countries of the East, been considered as the one manual which for the acquiring of a basic knowledge of the technicalities of the Buddhist Teaching should above all others be studied.

2. In the history of Buddhist literature *Abhidhammatthasaṅgaha* is a comparatively modern work in so far as it is only eight or nine hundred years old. As an important work of Buddhist scholarship, and as a manual or primer of Buddhist Teaching, it is, though, a book with a great ancestry and long lineage. As a summary of basic teaching it stands in the direct line of scriptural and exegetical material, extending from the time of the Enlightenment of the Buddha by way of his teaching to his followers, then from teacher to pupil within the monastic order and on through the centuries to the date of its composition: from there until the present day.

3. As a small and incisive source of knowledge it may therefore be considered as a kind of gem, in that within its small compass it exhibits brilliance, form and durability, wherein by its brilliance it represents the Buddha; by its form the nature and exactness of his teaching, the Dhamma; and by its durability his monastic order, the Sangha. But first to enlarge a little upon its ancestry and lineage, to show through what channels its substance has come and how those channels were formed.

4. According to Western calculations based on comparative historical research into the reign years of the ancient kings of India and Ceylon, the Buddha attained to his Enlightenment in or about the year 528 B.C. On the other hand Buddhist traditions of the eastern countries say that the Enlightenment took place at the time of full moon in the month of Vesākh, Kason (May) sixty-one years earlier than that, in the year 589 B.C. The really important feature, though, which arose out of the fact of the Enlightenment itself, is that it is from that time that the origins of our present knowledge of the Buddha's teachings emerge.

5. The ministry of the Buddha Gotama extended over a period of forty-five years, during which time he was an indefatigable teacher, moving about, it would appear, mostly in the more northerly parts of India but with local traditions of his having visited both Ceylon and Burma. His teachings have come down to us in two distinct streams, both of very ancient origin, and it is those streams which form the lineage or lineages of the book now under examination, *Abhidhammatthasaṅgaha*.¹

6. What are those two streams? The first is that of the basic scriptural texts, Pāli, from which word the West now names the language in which those scriptures, the *Tiṭṭaka*, are written. The second stream is that of the commentaries to those texts, *Atthakathā*. The basic texts themselves, i.e., *Vinaya*, the monastic rules and history; *Suttanta*, the discourses of the Buddha; and *Abhidhamma*, the teaching expressed in terms of ultimates, have come down to us preserved and checked by the six councils which have taken place. The first occurred immediately following the *Parinibbāna* of the Buddha; the most recent, the sixth at Rangoon in Burma in 1956, to celebrate the two thousand five hundredth year since the *Parinibbāna*.

¹ Ref. Chart No. 1.

Moreover, in addition to the recitations of the scriptures, it was at the fourth council during the reign of King Vattagāmini of Ceylon in the first century B.C. that the texts were officially committed to writing, consequently the author of *Abhidhammatthasaṅgaha* in the eleventh or twelfth century A.D. would in all probability have used a copy of that recension such as we too do today. That in brief is the first stream by means of which the lineage of the Buddha's teaching makes itself known.

7. The second stream, that of commentarial literature, is perhaps a little more complicated to explain, because although the occasion of its earliest appearance must have been of very early date, its origins, growth and progress through the centuries are very difficult to follow. Nevertheless, maybe a clue is given to its origin where, in a much later work called *Sāratthadīpanitīkā*, the attitude—at least of the Sangha—is shown in the following quotation: "There are indeed no items of text known as being unexplained by the Blessed One. Certainly an explanation for all was stated. From this it should be understood that the method of explanation of the three Piṭakas has indeed been taught by the Fully-Self-Enlightened-One. Commentary is therefore the various types of exposition originated by the Blessed One in this or that connection."

8. A little thought readily convinces one that the Buddha would not have taught for forty-five years only in the form of statements. Much explanation and elucidation would have been essential, particularly in connection with the positive meanings we find attached to technical terms. A great many of his immediate disciples were clearly men already most learned in Vedic matters, skilled analysts and logical disputants who, to understand fully the meaning and implication of the Buddha's word, would ask for much more detailed analysis than would appear in a basic statement. This is particularly so in the case of the strongly analytical and detailed matter of *Abhidhamma* where the whole aim is to specify fundamental principles rather than to speak in a general or illustrative manner. Without going into the question more deeply it is clear to see that whereas the Buddha's day to day teaching to the unscholarly was simple in form and readily understandable, the type of discourse he gave or discussion he had with those who at a much deeper level were intent on questions of moral principle, on the mechanics and functions of mental processes, on the nature of existence and so on, would have involved not only basic statement but would of necessity have been combined with much analysis, semantics and explanation.

9. It is, then, in this aspect of his teaching that there can be seen much of the origins of commentary. The view given in the *Sāratthadīpanitīkā*, although late, is strong, and from that it would suggest that established tradition held commentary as indeed originally based on the Buddha's own words. That expansions of meaning given by such leading disciples as Ven. Sāriputta and Ven. Mahākaccāna exist even in the Piṭakas themselves indicates clearly that learned comment existed and was made use of at that time. That Ven. Buddhaghosa lists the names of the succession of teachers (*ācariyaparamparāya*), not just reciters (*bhānakā*), who handed down *Abhidhamma* from the time of the Buddha till the third council, presupposes commentarial material by the very use of the word teacher. Such, then, would have been the origins, preservation, and growth of the most ancient commentaries.

10. But how is it known that such original commentaries existed? This is not too difficult to answer because both in ancient historical records and in the commentaries now existing they are mentioned by name; for example, *The Great Commentary*, *Mahā/atthakathā*; *The Ancient Commentary*, *Porana/atthakathā*; *The Scripture or Reference Commentary*, *Āgama/atthakathā*; though it should be mentioned that some scholars suggest these are different names for the same work. In what form have they come down to us? At the time of the third great council,

held under the Emperor Asoka in approximately 247 B.C., it is recorded in the ancient chronicles that the great Thera, Mahāmahinda, took the scriptures, the Piṭakas, to Ceylon. Further, in the introduction to the Dīgha Nikāya commentary of Buddhaghosa it is stated that he also took with him the commentaries which had been recited at the first and following councils. It also says that Ven. Mahāmahinda translated them into the Sihala language for the benefit of the islanders. From the records of a slightly later date in The Great Chronicle of Ceylon, the Mahāvamsa, it is said that at the time of King Vattagāmini both the texts and their commentaries were committed to writing. It is most unlikely that this was the first occasion on which such a thing had been done, since writing was already in regular use even before the time of the Buddha, but it may well be looked upon as the earliest written "authorized version." This would have occurred sometime during the first century B.C. Very little more seems to have been said about the old commentaries until about the fifth century A.D. when Ven. Buddhaghosa, the famous translator and scholar Bhikkhu, took these old commentaries together with additional native Sihala commentaries compiled since the time of Ven. Mahinda, and, with some compression in order to reduce repetitious matter as much as possible, translated them into the language of the scriptures (Pāli). These, with some few additions by other famous translator Bhikkhus, are the commentaries we possess today, and which together with some later sub-commentaries (*tika*), form the second stream of the lineage of the Buddha's teaching. It is, then, against the background of these two streams of lineage, the scriptures, and their commentaries, together with the very strong practical traditions existing within the Sangha of instruction and elucidation, that Abhidhammatthasaṅgaha was written. But now to turn to the origins of the book itself.

11. It was written by a Thera named Anuraddha who, it is recorded, was born in the town of Kāveri in the district of Kancipura in the Cola country of South India. It is said that he dwelt sometimes in a town, named Tañja (Taṅjore?) in the Tamba country, also in South India, and sometimes in the island of Sihala, Ceylon. He became the incumbent of the Mulasome Vihāra, an ancient monastery at Polonnaruwa, founded, according to tradition, by King Vattagamini's queen Somadevi and a minister named Mūla. It was at this monastery, at the request of one of his pupils named Namga (or Namba), that he is said to have written Abhidhammatthasaṅgaha, making use of the entire Abhidhamma Piṭaka together with its commentaries and working continuously until it was complete.

12. There seems to be some uncertainty as to the date of composition of this important manual, some saying that Ven. Anuraddha was born shortly before or early in the reign of King Parakkambāhu the Great, 1153-1186 A.D., others that it was written during the reign of an earlier monarch, King Vijayabāhu, 1070-1110 A.D. However, in view of there having been commentaries written on it by both Ven. Mahākassapa and Ven. Sāriputta during the reign of the later king it may well be that it was the earlier period that saw its advent.

13. Abhidhammatthasaṅgaha itself is a slim volume of roughly a hundred pages. In this small compass though, it compresses all the salient points of the entire seven sections of that Abhidhamma Piṭaka, thereby enlarging as an essential primer with which the earnest student of the analytical teachings of the Buddha contained in that Abhidhamma Piṭaka should become well acquainted before launching into those far more complex works.

14. At this point a question may very well rise in the mind concerning the strong emphasis so often placed on this matter of analysis. Analytical methods and analytical teaching, asking whether such a seemingly mundane and unspiritual approach is useful, or indeed even relevant, to what may seem such delicate, sensitive, and personal subjects as religion and religious

understanding. The Answer to such questionings rests on what is intended when one thinks of religion, even though this may never have really been considered in terms of actual definitions.

15. The word itself can be connected with two Latin sources, "religionum" and "relegere." The first is quite clear, it means: reverence to the gods, fear of god, consciousness of wrong, religious scruple. The second, though quite different, is equally clear, it means: to gather together, to collect, to ponder over, to give heed to, observe, care for.

16. With two equally valid, yet so very different, ways of defining religion, it is without doubt a practical thing to do to look at the Buddhist Teaching on a comparative basis to see in accordance with which definition it should be understood, and as the outcome of that how its study should be approached. What then can be said to define the characteristics of Buddhism as a religion?

17. Buddhism is a religious system which in no way seeks to discuss a relationship existing between mankind and a deity; rather it sets out to view the conditions existing both within oneself and without, examining the relationships between them, seeking to observe and comprehend in results the nature of the causes governing them and pointing to the way by which the tangle caused by ignorance may be unravelled and a stable state to view clearly and with acute penetration all that is of the mind and all that is of material qualities, and, unclouded by ignorance, to see them as they are in reality.

18. The Buddha's Teaching is therefore a process which, by a proper practice in gaining understanding of the true nature of all there is, leads to that stable state. If, as this statement makes clear, the Buddha's Teaching is shown to be the gaining of understanding of the true nature of all there is of mind and material qualities, then clearly it is the second definition of religion that is most nearly applicable to it, i.e., to gather together, collect and ponder over, to give heed to, observe and care for.

19. That, then, is why so great an emphasis is placed on examining and analysis, and why even at the time of King Asoka, only two hundred and twenty or more years after the Parinibbāna of the Buddha, the Teaching was described as Vibhajjavāda, the Doctrine of Analysis.

20. Before examining the contents of Abhidhammatthasaṅgaha itself, mention should be made of one matter, not unconnected with the very arrangement of its chapters and the terse manner of its statements. It is to prepare those who may not previously have made contact with the methods of Abhidhamma teaching, who might at this early stage and without prior guidance wonder in what possible way such seemingly scholastic material could ever be of the slightest help towards that unique teaching of the Buddha, the gaining of penetrative knowledge or Insight (*vipassanā*).

21. To dispel any such doubts or questionings it is necessary to draw attention to and emphasize the fact most strongly that there are two distinct methods by which such insight is to be arrived at. Both methods are directed to penetrative knowledge, insight, or realization of the three characteristics, i.e., impermanence, unsatisfactoriness, and absence of soul (*anicca, dukkha, and anattā*). The first is that of gaining insight specifically into those three, based on the knowledge and practice of jhāna. The second is the gaining of that very same insight but basing progress on the path of analytic knowledge. Insight gained in this second way is known as dry-insight, and its fulfillment depends much on the teaching and methods of Abhidhamma.

22. Abhidhammatthasaṅgaha, the title of the book, means: a compilation, Summary or Compendium (*saṅgaha*) of both the subject matter and the Meaning (*attha*) of the Teaching

expressed in terms of Ultimate Conditions (Abhidhamma). In order, therefore, to combine the two aspects of subject matter and meaning, Abhidhammatthasaṅgaha can be translated as "A Summary of the Substance of Abhidhamma." The book consists of two introductory verses, nine chapters and two closing verses.

23. The order of arrangement of the chapters may at first sight seem strange, but acquaintance with them will show the method to be very sound in that it makes no attempt to approach things quickly, and consequently, by mixing information, cause confusion. On the contrary, it teaches only what it is necessary to know at each stage so that knowledge and understanding may be built up steadily and logically.

24. 1) The first chapter, Consciousness (*citta*), deals exhaustively but without complication with the types and states of mind which can occur with beings.

2) The second chapter entitled Mental CONCOMITANTS (*cetasikā*) enumerates the factors which give those states of mind their particular attributes and shows in what manner they group and operate together.

3) The third chapter, SPECIAL ITEMS (*pakinnaka*), details the ancillary conditions necessary to the arising and presence of those integral states of mind together with certain aspects of their presence.

4) Having in the previous sections dealt with a static analysis of the various states, the fourth chapter entitled PROCESS (*vīthi*), shows their kinetic behaviour; that is, their mode of coming to be, progress and passing away.

5) The fifth chapter, PROCESS FREE (*vīthimutta*), closes the section concerned purely with mental phenomena by dealing with matters directly associated with them, such as planes of existence, rebirth, action, and death.

6) The sixth chapter, MATERIAL QUALITIES (*rūpa*), specifies the primary and derivative qualities of matter in accordance with the Buddha's teaching of Abhidhamma. The chapter closes with a short section dealing with the UNCONDITIONED ELEMENT, NIBBĀNA (*asaṅkhata-dhātu: Nibbāna*).

7) Chapter seven, entitled COMPOSITE GROUPS (*samuccaya*), details the collections of Abhidhamma and Suttanta terms which from their particular qualities have direct bearing on the mental and material qualities already enumerated.

8) Chapter eight, CAUSAL RELATIONSHIPS (*paccaya*), is threefold in content: (1) paṭiccasamuppāda, which states the general law of the arising of result depending on a cause, which result itself becomes the cause for the arising of a subsequent result, and so on in a twelve constituent cyclic series operating continuously until its continuity is broken by the non-arising of CRAVING (*tanhā*). (2) Patthāna, which elucidates the twenty-four conditions which in relevant selection are essential to the existence of, and uninterrupted connection between, the individual states operating within such a causal series. And (3) paññātti, the nature of concept.

9) Chapter nine, the final chapter, is called THE FUNDAMENTALS OF THE PRACTICE (*kammaṭṭhāna*) OF MENTAL DEVELOPMENT and it deals with the two basic types of MENTAL DEVELOPMENT (*bhāvanā*) and the objects associated with its practice.

25. From this it can readily be seen that the subject arrangement of Abhidhammatthasaṅgaha is strictly progressive in that it leads the student gently from the simple to the increasingly more complicated, but in such a manner that he is always prepared

for what is to come next. The teaching is not therefore directed towards producing a rapid superficial result in which knowledge is random and disconnected, but to the developing of a proper basis upon which comprehension of the subject may grow satisfactorily. For this reason it is slow and thorough, with every single sentence containing material of importance to the growth of such comprehension.

26. For centuries the practice in the East has been to learn the whole book by heart before even commencing study. This may seem to many to be taking the subject over seriously, but it is worthy of much consideration as there exists the very simple parallel of learning by heart the multiplication tables, a feat commonly considered to be quite indispensable. Why, then, should not the same attitude be taken towards the basic material upon which, after all, may well stand one's forward progress to seeing things as they really are.

(Talk One: Part Two)

27. It is the custom in Buddhist countries to prefix any book written on subjects concerned with the Teaching (*dhamma*) with the following words: NAMO TASSA BHAGAVATO ARAHATO SAMMĀSAMBUDDHASSA. Abhidhammatthasaṅgaha is no exception to this custom. What then is the meaning of this phrase, and what is its purpose?

28. As to meaning its individual words may be translated as follows: NAMO means: honor, veneration, salutation, homage or respect, TASSA means: to him. BHAGAVATO means: to the Lord, the Illustrious, the Sublime, the Fortunate. ARAHATO means: to the Perfected One, the Worthy, the One who has reached the goal. SAMMĀSAMBUDDHASSA means: to the Fully-Self-Enlightened-One, the One possessed of supreme penetrative insight.

29. Its purpose is to make known that honor, respect and veneration are due and are accorded to the Lord who is illustrious by virtue of the sublimity of his achievement; to the Perfected One who is worthy in the sense of having reached the goal; to the Fully-Self-Enlightened-One who, by virtue of having achieved by his own effort supreme penetrative insight with full knowledge, understanding and faultless ability, makes known the Truths and Characteristics of existence. Therefore it is said:

VENERATION TO HIM, THE LORD, THE PERFECTED ONE, THE FULLY-SELF-ENLIGHTENED-ONE.

30. The text to be used throughout this series of talks was published by the Union Buddha Sāsana Council of Burma in 1970. It is in the Pāli language and is printed in Burmese characters. In the course of preparing the talks in written form the transliteration of the Burmese characters into roman will be done strictly in accordance with that text, but in order to make the component parts of the Pāli words more apparent they will be hyphenated where it is suitable, and a dot used where it may be helpful to show that there is a junction within a word where a vowel has been assimilated, or where conjunct consonants are not normally separated in Eastern orthography.

31. When translating from Pāli into English the following procedure will be adopted. The Pāli words from the original text will be bracketed and in lower case letters. They will be preceded by their direct or near English equivalents in capital letters. Where meaning can be clarified by using extra English words these will be added in unbracketed lower case letters. This method is being used because the word order in Pāli sentences is very different from that of English.

VERSE 1.

32. Abhidhammatthasaṅgaha opens with a short introductory stanza, or "Prologue to the Work," wherein salutation is first made to the Buddha, the Dhamma, and the Sangha, followed by a statement in which the purpose of the whole work is put forward. The Pāli is as follows:

SAMMĀ-SAM-BUDDHAM ATULAM
SA SADDHAMMA GAN UTTAMAM
ABHIVĀDIYA EHĀSISSAM
ABHIDHAMMATTHA-SANGAHAM

By rearranging the word order to suit English syntax this verse can be translated as follows:

SALUTING (*abhivādiya*) THE INCOMPARABLE (*atula*) THE FULLY (*sammā*) SELF (*sa*) ENLIGHTENED-ONE (*buddha*) TOGETHER WITH (*sa*) THE TRUE TEACHING (*saddhamma*) and

THE EXALTED (*uttama*) ASSEMBLY (*gana*) I SHALL DECLARE (*bhāsissam*) A SUMMARY (*saṅgaha*) of THE SUBSTANCE (*attha*) of ABHIDHAMMA (Abhidhamma).

33. To explain this stanza a little more fully it should be said that the expression “the True Teaching” refers not just to the Teaching as it exists in books, or as it is taught in a general way, but to the Teaching spoken by the Buddha himself, leading to the non-arising of CRAVING (*tanhā*) and thereby to the CESSATION OF SUFFERING (*dukkha-nirodha*). The expression “the Exalted Assembly,” refers not just to the Sangha as a whole, but to the Ariya Sangha, or Noble Order of Bhikkhus, who by virtue of their practice of the True Teaching of the Buddha have encompassed the non-arising of craving, and have come thereby to that Cessation of Suffering.

VERSE 2

34. Before looking at the text of the second stanza there is one Pāli word which needs to be thought about a great deal, because although its use is infrequent, an understanding of its meaning is presupposed from the very beginning of Abhidhammatthasaṅgaha. The word is PARAMATTHA. It occurs in this second verse, but the sense of its meaning pervades, and is essential to not only this particular book but to every aspect of Abhidhamma studies.

35. When comparing the dialogues of the Suttantapiṭaka with the very terse and technical style of the Abhidhamma Piṭaka, two things are immediately apparent. First is that the dialogues are easy to read and relatively clear in their meaning. This is so not only because of the use of much pictorially descriptive matter and explanations at a personal level, but because the Buddha himself sifts and graduates the points at issue, and refines the manner in which those points should be viewed. In strong contrast to this it is seen that the texts and methods of Abhidhamma Teaching are in every way the reverse of the Suttanta method, in that there is no narrative material, no discussion, and no direct suggestion as to the way a point should be viewed. Certainly there are questions and answers, but these are framed in such a way that it can be suspected with some reason that the purely hypothetical questioner already knows a great deal, in as much as the questions themselves are clearly defined and precisely to the point. In what way then can these differences be resolved?

36. To explain it in the simplest way is to say that in Sutta the Buddha was using words largely in their everyday sense, employing many words to express a particular idea. On the other hand, in Abhidhamma he used words in a special or technical sense, as having exact, specific, or definitive meanings. He used those terms in what one might call their philosophical aspect; that is, taken away from their pictorial surroundings and personal connotations, so that their meanings could be understood as being so basic or fundamental as to remain quite unchanged in whatsoever context they appeared. In Suttanta, therefore, it can be said that words were used in an “ordinary” way; in Abhidhamma in a “particular” way, or, to be more specific, in their definitive, as contrasted with their conventional sense. In Abhidhamma Teaching though, the word “definitive” still does not go quite far enough, for there the Buddha expressed his Teaching in terms of ULTIMATE TRUTH (*paramattha-sacca*) as contrasted with CONVENTIONAL TRUTH (*sammuti-sacca*).

37. It has been said that the aim and purpose of the Teaching of the Buddha is to so clear the mind of FALSE VIEW (*micchā-diṭṭhi*) as to be able to have KNOWLEDGE OF THINGS AS THEY ARE IN REALITY (*yathābhūtanana*). In what way can this be explained?

38. The classical explanatory example is given in an ancient popular Buddhist book entitled THE MILINDA QUESTIONS (Milinda-panha), where a discussion is recorded between King

Milinda² and the Arahanta Nāgasena. Here the King accuses Ven. Nāgasena of speaking falsehood when saying that although he is called Nāgasena, there is in reality no Nāgasena, only the FIVE AGGREGATES (*pañca khandhā*) of existence, none of which is itself Nāgasena. Ven. Nāgasena then explains to the King, using the simile of the chariot, that it can be shown that in the ultimate sense of real, intrinsic existence there can be said to be no such object as a chariot apart from its component parts; shaft, wheels, axle, body, flagstaff, yoke, reins and goad; yet none of these is “chariot” either. From which it may be seen that the existence of “chariot” is only a conventional truth, a mode of expressing the function of a number of parts when operating together within a specific context or framework of VIEW (*diṭṭhi*). The definition of an object, quality, or state in ultimate terms is, then, that which specifies its true value when removed from any context or view. Thus Ven. Nāgasena spoke in accordance with the Teaching when saying “chariot” did not exist in an ultimate sense, but only in a conventional sense, it being merely the contextual name for an assemblage of components. In the same way “Nāgasena” could not be said to exist in an ultimate sense but only in the conventional sense as the contextual name for an assemblage of component parts; the five aggregates, which could indeed be expressed in terms of ULTIMATES (*paramattha*).

39. It is a feature of Abhidhamma that lengthy explanations of the meaning of particular words is often necessary, especially in the case of those intended to be understood in this ultimate sense. The study of the meaning of words, semantics, becomes therefore an integral part of Abhidhamma studies in that by grasping their meaning the Teaching of the Buddha becomes apparent. Consequently, as the outcome of just such study, the word paramattha should be understood as meaning ULTIMATE THING (*parama + attha*), that is, something which cannot be further broken down and expressed in terms of component parts; something which, in whatever context it is present, exhibits the same attribute.

40. The Pāli of the second stanza is:

TATTHA VUTT-ABHIDHAMM-ATTHA
CATUDHA PARAMATTHATO
CITTAM CETASIKAM RUPAM
NIBBĀNAM ITI SABBATHA

Which translated is:

The ABHIDHAMMA CATEGORIES (*Abhidhamma + attha*) STATED (*vuttā*) THEREIN (*tattha*—i.e. in the Abhidhammapīṭaka) are FOURFOLD (*catudhā*) IN TERMS OF ULTIMATES (*paramatthato*): COLLECTIVELY THUS (*iti sabbathā*), CONSCIOUSNESS (*citta*) MENTAL CONCOMITANTS (*cetasika*) MATERIAL QUALITIES (*rūpa*) NIBBĀNA (*Nibbāna*).

From which it may be seen that basically there are four mutually exclusive groups, each of which is ultimate in the sense that it can neither be further broken down into component parts nor expressed in terms of any of the other groups. Thus CONSCIOUSNESS (*citta*) in its ultimate usage means: just to be aware (of an object), awareness—nothing more, nothing less. MENTAL CONCOMITANTS (*cetasika*), referring to the Commentary Attasālini means: that which is “joined inseparably with consciousness.” It refers thereby to a number of separate and distinct qualities which, though themselves in no way identifiable as being consciousness, nevertheless arise, exist and pass away together with it, imparting as is suitable various attributes to produce integral states classifiable according to those attributes. MATERIAL QUALITIES (*rūpa*) means: that which is matter, material, material substance, material qualities, and which thereby is not

² The Graeco-Bactrian King Menander, ca. 165-130 B.C.

consciousness, not mental concomitants, not Nibbāna. NIBBĀNA, being a very difficult word for which to find any suitable English equivalent, is customarily left untranslated. As explanation of its nature though, the Commentary Atthasālini, when likening CRAVING (*tanhā*) to a JUNGLE (*vāna*, meaning both craving and jungle) says that to have GOT AWAY (*ni + ggata*) from that jungle is the meaning of NIBBĀNA (*ni + vāna*). Freedom from craving being the criterion, the absolute realization of Nibbāna means therefore: knowledge and awareness of that which consciousness takes as object at the time of its becoming utterly freed from craving. Nibbāna is also known as that from which there is NO PASSING AWAY (*accuta*), as SUPREME COMPLETION (*accanta*), as UNCONDITIONED (*asaṅkhata*), as NOT SURPASSABLE (*anuttara*).

41. Referring again to the four categories of ultimates another point arises. Among the descriptive terms for Nibbāna it was defined as UNCONDITIONED (*asaṅkhata*). Two questions arise out of this; the first is, what is meant by unconditioned; the second, are the other three, that is, consciousness, mental concomitants and material qualities, able to be defined by that same term? In order to answer these two questions satisfactorily it would be better to approach the second one first, and the answer to that is "no." Consciousness, mental concomitants and material qualities can in no way be classified as being unconditioned. How is this so? They come to be only by virtue of there being suitable causes, therefore they cannot be said to be uncaused. For example, consciousness and its associated mental concomitants occur only in the presence of certain essential prerequisites such as an object, the appropriate organ of sense, suitable conditions such as light in the case of visual objects, and the appropriate type of contact between the sense organ and the object; then only can awareness and such other concomitant qualities as feeling, perception, etc., occur with regard to that object. Consequently consciousness and mental concomitants can only be said to arise by virtue of the presence of suitable conditioning features. Regarding material qualities it is abundantly evident that they are greatly affected by many causes, natural causes such as heat, cold, wind, rain, nutrients, time and so on. As the result of this; they are said to be conditioned by such forces. The answer to the second question is, therefore, that consciousness, mental concomitants and material qualities are CONDITIONED (*saṅkhata*) and are consequently never to be considered as UNCONDITIONED (*asaṅkhata*).

42. In answer to the first question then, "what is the meaning of unconditioned?," it may be said by way of sharp contrast that Nibbāna, not being associated with any cause, is thereby not subject to change, consequently it cannot be said that it is influenced in any way whatsoever by conditioning forces; therefore it is said of Nibbāna not that it is conditioned but that it is unconditioned.

43. It is this difference between the conditioned and the unconditioned that affords a glimpse of the three salient characteristics of Buddhist Teaching, IMPERMANENCE (*anicca*), UNSATISFACTORINESS (*dukkha*), and ABSENCE OF SOUL (*anattā*). That which is conditioned by causes upon which it is dependent cannot be other than IMPERMANENT (*anicca*). If it be impermanent it cannot be anything steadfast and to be relied upon. To that extent it is UNSATISFACTORY (*dukkha*). In addition to this, if impermanent and therefore intrinsically incapable of permanence, it cannot from that very fact be said to possess any permanent and enduring SOUL or SUBSTANCE (*atta*); therefore in speaking of conditioned things the Buddha always stressed these THREE SALIENT CHARACTERISTICS (*tilakkhanā*), Impermanence, Unsatisfactoriness and Absence of Soul.

VERSE 3.

44. With the third verse comes the true beginning of Abhidhammatthasaṅgaha, because it is from this point that an actual examination takes place of the four ultimates of the immediately preceding stanza. The examination occupies the initial five chapters, and commences with consciousness. The Pāli of verse three is as follows:

TATTHA CITTAM TĀVA CATU BBIDHAM HOTI KĀM
ĀVACARAM RŪPĀVACARAM ARŪPĀVACARAM LOK
UTTARAN CE TI

Meaning:

IN THAT CONNECTION (*tattha*) CONSCIOUSNESS (*citta*) IS (*hoti*) FIRST (*tāva*) and has FOUR (*catu*) DIVISIONS ((b)*bidha* = *vidha*) THUS (*iti*), consciousness CHARACTERISTIC OF THE PLANE OF (*āvacara*) SENSE DESIRE (*kāma*), CHARACTERISTIC OF THE PLANE OF FORM (*rūpa* + *āvacara*), CHARACTERISTIC OF THE FORMLESS PLANE (*arūpa* + *āvacara*) AND (*ca*) SUPRAMUNDANE (*loka* + *uttara*).

45. Following this verse a certain amount of explanation may be helpful. For example it will shortly be necessary to speak of many states of mind, all of which comprise both CONSCIOUSNESS (*citta*) and MENTAL CONCOMITANTS (*cetasikā*) yet which in this manual are still referred to just as consciousness. In the books of the Abhidhammapiṭaka though, such compounded structures are generally known as "CITTA-CETASIKĀ-DHAMMA," which means literally "STATES comprising CONSCIOUSNESS and MENTAL CONCOMITANTS," To use such a term is undoubtedly clear and unambiguous, particularly as it allows the individual terms still to show their ultimate nature; since, however, in Abhidhammatthasaṅgaha consciousness is used in both ultimate and compound senses, it has been thought useful here to differentiate between them by referring to consciousness in its ultimate sense as FACTORIAL CONSCIOUSNESS and in its compounded usage as INTEGRAL CONSCIOUSNESS or INTEGRAL STATES.

46. And now the three items: Consciousness Characteristic of the Planes of Sense Desire, Form, and the Formless. Integral states are frequently grouped in accordance with a characteristic most generally apparent or associated with their coming to be. Thus in the case of Integral States Characteristic of the Plane of Sense Desire the feature most readily recognizable as being fundamental to them is the innate need for stimulation and feeling of satisfaction by way of the five organs of sense in the form of sights, sounds, smells, tastes and touch. The need for stimulation of this kind is called SENSE DESIRE (*kāma*), and is the basis of one group of integral states, a group which in general represents the states of mind which arise in the course of ordinary everyday mundane or worldly existence; therefore it is known as Integral Consciousness CHARACTERISTIC OF THE PLANE OF SENSE DESIRE (*kāma* + *āvacara*).

47. The second group, Integral Consciousness Characteristic of the Plane of Form, represents a very different category of integral states, because here, instead of the wild and almost random seeking for sense stimulation as in the class just mentioned, there is determined effort directed towards the calming, stabilizing and strengthening of mental activity by the systematic inhibition of factors hindering such achievement. Nevertheless, even with the refining and purifying of mental states by strict control of sense stimulation, use is still made in a finer and more tenuous sense—of material substance or materiality as the initial object of consciousness upon which to build and develop mastery over unwanted factors. Despite this refining though, since MATERIAL QUALITY or FORM (*rūpa*) is indeed the object upon which such states are

initiated, they are grouped together as Integral Consciousness CHARACTERISTIC OF THE PLANE OF FORM (*rūpa + āvacara*).

48. Consciousness Characteristic of the Formless Plane is to be regarded as an even more refined and therefore a higher degree of development than that of the previous group, in as much as its practice considers even the most tenuous aspect of material quality as being far too coarse a basis or support for the most refined and lucent states of consciousness. Consequently, since further development rejects materiality, adopting NON-MATERIAL (*arūpa*) concept in its stead, this grouping is known as Integral Consciousness CHARACTERISTIC OF THE FORMLESS PLANE (*arūpa + āvacara*).

49. Throughout these groupings the phrase “characteristic of the plane of” has represented the Pāli word “*āvacara*,” literally, though, it means: to move about in, to be familiar with,—or, by association of ideas—related to, supported by, dependent on, contingent upon. In the context of grouping states of mind in the above manner, any or all of these definitions are adaptable to the sense in which *āvacara* is intended. However, for reasons arising out of a far wider scope of meaning which will become apparent at a later stage, the use of any such values as those mentioned above may well prove restrictive, consequently the already well established and much broader equivalent “characteristic of the plane of” is used.

50. The final group of four, comprising consciousness, is that known as Supramundane. SUPRAMUNDANE (*lokuttara*) Consciousness refers to those integral states which take as their object that which is BEYOND (*uttara*) the WORLD (*loka*). This can by definition refer to one object of consciousness only—Nibbāna—the unconditioned element. Consequently only those who by their degree of realization have permanently cast away certain fetters (*saṃyojanāni*) binding them to mundane thought and practice, can be said to take Nibbāna as the object upon which consciousness arises.

51. Verse three, therefore, defines the basis upon which the many and varied integral states can arise, and it is on this same basis that there follows in this first chapter of Abhidhammatthasaṅgaha a full statement and simple system of arrangement of all possible states. Bearing in mind that the method of Abhidhamma is directed not just to study, but essentially to practice, this statement and arrangement is designed for use as a yardstick, or map, against which to check the character of one’s own states of mind and thereby observe their quality as to whether they are UNSKILFUL (*akusala*) or SKILFUL (*kusala*), and from that to decide whether such thought and subsequent action is leading away from or towards a KNOWLEDGE OF THINGS AS THEY ARE IN ULTIMATE REALITY (*yathā-bhūtonana*).

Talk Two (Part One)

52. Before embarking upon the fourth verse it would be helpful to deal with a number of rather special points. The need for this arises out of the structure and arrangement of Abhidhammatthasaṅgaha itself, which, being so terse in its statements, is best looked upon as a most valuably arranged series of facts and notes for learning and reference rather than as a book to be read. Because of this very feature, though, there is a necessity for it to be expanded with a great deal of background material and explanation in order to bring the bald statements to life, and thereby show their applicability to everyday experience.

53. For example, bearing in mind the four categories of verse three (*kāmāvacara*, *rūpāvacara*, *arūpāvacara*, *lokuttara*), consider just the opening words of verse four, they are:

TATTHA KATAMAM KĀMĀVACARAM

Meaning:

WHICH (*katama*) OF THESE (*tattha*)³ are CHARACTERISTIC OF THE PLANE OF SENSE DESIRE (*kāmāvacara*)?

To make this rather clearer, some expansion may help, for in effect it means:

“Which among the many integral states are those characterized by having an innate need and feeling of satisfaction for stimulation by way of the five doors of sense?”

In other words, which integral states are classifiable as being Characteristic of the Plane of Sense Desire? Phrased as it is, such a question does not give any indication of the method or basis upon which these Kāmāvacara states may be isolated from the other three groupings, consequently some background material is necessary. To find this the best place to seek is somewhere in the original books of the Abhidhammapiṭaka itself, because these are the ultimate source of any such supporting material.

54. At the very beginning of that Piṭaka, in that book entitled Dhammasaṅgani,⁴ there exists a short but very important section known as *mātikā*. This word “*mātikā*” is frequently used in the sense of being just an index or table of contents; in Dhammasaṅgani though, it plays a much more important role, for here it is the matrix (cp. *mātikā*), or mould, from which the whole of the Abhidhammapiṭaka takes its internal structure. Moreover, in the sense that the word “*mātikā*” can be interpreted as “like a mother” (*mata + viya*, ref. Abhidhānappadipikasuci), so the Mātikā of Dhammasaṅgani may be said to be as a MOTHER (*mata*) to the whole Abhidhammapiṭaka in that the contents of that Piṭaka originate and grow from that same Mātikā, and are beholden to it at all times.

55. At this stage there is no need to discuss this important introductory section in detail, it being sufficient to say that in the main it consists of twenty-two groups of threefold classifications and one hundred groups of twofold classifications, each of which, according to its particular scope, constitutes a systematic means of examining all that is included in the fields of MENTAL QUALITIES (*nāma*) and MATERIAL QUALITIES (*rūpa*). However, the reasons for speaking of Dhammasaṅgani Mātikā at all at this stage are of considerable importance quite apart from its position as being the authentic background for much of the terse statement of Abhidhammatthasaṅgaha. The first, of these reasons is to emphasize that it is not from any external or later source that the structure upon which the method of Abhidhamma analysis is based and is to be found, but from the very beginning of this book Dhammasaṅgaṇī. Here is made plain by means of the Mātikā the entire basis upon which any really exhaustive

³ Lit. THEREIN, i.e. among conscious states.

⁴ Buddhist Psychological Ethics, P.T.S. 3rd edition, 1974.

consideration of mental and material phenomena should be conducted, so that they may be viewed in terms of ultimates. The second reason is to show that when the author of Abhidhammatthasaṅgaha devised his particular method for displaying the many integral states, he did so not in any random manner but by choosing carefully from that same series of special categories already laid down by the Buddha as the proper basis for any such exposition.

56. In this connection then the classifications selected from the Dhammasaṅgani Mātikā, which Ven. Anuruddha uses in conjunction with one another, are as follows:

First whether a state is:

57. 1) GOOD (*kusala*), sometimes called skilful or wholesome.
2) BAD (*akusala*), sometimes called unskillful or unwholesome.
3) NOT DESIGNATED (*abyakata*), i.e., not classifiable under either of the above groups.

Second, whether a state is associated with:

- 4) PLEASURE (*sukha*).
5) PAIN (*dukkha*).
6) HEDONIC NEUTRALITY (*upekkhā*).

Third, whether as a state it is:

- 7) RESULTANT (*vipāka*).
8) -
9) -

Fourth, whether as states they are:

- 10) ROOTS (*hetu*).
11) -

Fifth, whether they are:

- 12) ACCOMPANIED BY ROOTS (*sahetuka*).
13) NOT ACCOMPANIED BY ROOTS (*ahetuka*).

For reference purposes the appropriate groupings from the actual text of the Tika and Duka Mātikā are quoted in full as follows:

From the TRIPLE MATRIX (*tika mātikā*):

- 1) Kusalā dhamma.
2) Akusalā dhamma.
3) Abyakatā dhamma.
4) Sukhāya vedanāya sampayuttā dhammā.
5) Dukkāya vedanāya sampayuttā dhammā.
6) Adukkhamasukhāya vedanāya sampayuttā dhamma.
7) Vipāka dhamma.
8) Vipāka-dhamma-dhammā.
9) Neva-vipāka-na-vipākadhammadhammā.

From the DUAL MATRIX (*duka mātikā*):

- 10) Hetu dhammā.
11) Na hetu dhammā.
12) Sahetuka dhammā.
13) Ahetuka dhammā.

58. In this way Ven. Anuruddha, by selecting eleven suitable items from five Mātikā categories, together with occasional essential additions from other groups, was able to arrange his own system of classification in a simple but clear and compressed manner.

59. But what of these various categories so far as meaning is concerned, because in being selected from the classifications of the Mātikā they involve four completely dissimilar modes of approach, i.e., Ethical Values; Feeling; Resultant States and Roots? For the moment an explanation of Resultant States can be postponed, but the other three need some qualification because they are directly concerned in the initial group of integral states about to be discussed.

GOOD and BAD (*kusala, akusala*).

60. From the first group of three how are GOOD (*kusala*) and BAD (*akusala*) to be assessed ethically? Put in its most simple form the Teaching of the Buddha is directed specifically to the overcoming and destruction of IGNORANCE (*avijjā*) and CRAVING (*tanhā*). This is achieved by means of practice along the clearly defined paths of MORALITY (*sīla*), MENTAL DEVELOPMENT (*bhāvanā*) and the attaining of PENETRATIVE WISDOM (*paññā*). Having this in view, "bad" may thereby be defined as that which is most nearly associated with ignorance and craving, whereas "good" is that most nearly associated with the gaining of understanding and penetrative wisdom. From this it may be seen that there exists a scale of readily identifiable values ranging from the very lowest—i.e., from evil bad states associated with the deepest and most overwhelming ignorance—to the most high—i.e., to faultless good states associated with supreme penetrative wisdom.

61. Practice of the good is therefore that which lifts one up the scale from states dominated by ignorance and craving to those characterized by wisdom and understanding. Conversely, practice of the bad is that which, by associating itself ever more deeply and more intimately with ignorance and craving, descends the scale of progress. Practice, though, is of three different types; of thought, of speech and of action. Consequently good practice is wholly concerned with healthy, faultless, blameless, and skilful thought, speech, and action. Such practice strives always to be away from and ultimately to destroy ignorance and craving, and at the same time to approach nearer to the acquiring of wisdom. Effort of this kind is always productive of helpful and happy resultant, progressive in that it leads towards the goal. Opposed to this is bad practice; unhealthy, faulty, blameworthy and unskilful thought, speech and action, that never strives to be away from but always consorts with ignorance and craving, sinking more and more deeply into its association with them. Such practice can never be productive of helpful, happy resultant, or be progressive towards better states, it will always result in loss, and the diminution of any gain previously made.

62. The Commentary,⁵ as the first of several derivations, explains that "kusala" is so called because it causes CONTEMPTIBLE (*KUcchita*) states to SHAKE (*SALAyati*), to tremble, waver, and be destroyed. It lists its equivalents as: HEALTHY (*ārogya*), FAULTLESS, BLAMELESS (*anavajja*), SKILFUL (*cheka*), and HAPPY IN RESULTANT (*sukha-vipakesu*). Apart from these it is also frequently translated as moral, good and wholesome. Any of these many values may therefore be used according to their immediate suitability.

63.⁶ To return now to the text of Abhidhammatthasaṅgaha. Initially the division of Integral States Characteristic of the Plane of Sense Desire is threefold, as BAD STATES (*akusala dhammā*), STATES WITHOUT ROOTS (*ahehetukā dhammā*) and SHINING or BEAUTIFUL STATES (*sobhanā*

⁵ Expositor pp. 48-50.

⁶ See chart 3.

dhammā). In view of what has just been said, of the selection of groupings from the Mātikā, why has this seemingly irregular choice been made? The clue is to be found in the group called “States Without Roots.” It is here that the category of ROOTS (*hetū*), mentioned earlier as coming from Dhammasaṅgani Mātikā, is first brought into use; and it is by subdividing the three groups given above, in terms of appropriately chosen roots, that a great number of integral states can be dealt with, and their relationships with each other very readily shown. What then are roots?

ROOTS (*hetū*).

64.⁷ The idea of roots arises from a knowledge of plants, wherein it is evident that a plant grows strongly and fully by virtue of its having an adequate root structure; moreover, that the root is ultimately dependent on there having been a seed from which not only the plant with its flowers and fruit has sprung, but also the very root itself supporting those flowers and fruit and by which all are characterized. In a comparable way it may be said of beings. They come to be as the resultant of their past bodily, verbal, and mental actions, and it is these which are the seeds from which the being, together with the root structure supporting it, ultimately arises, and by which both are characterized. Such past action will itself have originated among, and have been appropriately nourished by, GOOD ROOTS (*kusalā hetū*) and BAD ROOTS (*akusalā hetū*), which, supporting a being as its flower, will have resulted in the seed from which a later being springs—together with its supporting roots, which are:⁸

BAD ROOTS (*Akusalā hetu*):

THE BAD ROOT OF GREED (*lobho akusala-hetu*).

THE BAD ROOT OF HATRED (*dosa akusala-hetu*).

THE BAD ROOT OF DULLNESS AND DELUSION (*moha akusala-hetu*).

GOOD ROOTS (*kusala hetu*):

THE GOOD ROOT OF ABSENCE OF GREED (*alobho kusala-hetu*), i.e., generosity.

THE GOOD ROOT OF ABSENCE OF HATRED (*adoso kusala-hetu*), i.e., loving kindness.

THE GOOD ROOT OF ABSENCE OF DULLNESS AND DELUSION (*amoho kusala-hetu*), i.e., wisdom.

65. With these ideas in mind, and viewing Buddhist Teaching as a system of training and practice wherein RIGHT EFFORT (*sammā-vāyāma*)—the sixth item of the NOBLE EIGHT-CONSTITUENT PATH (*ariya atthangika magga*)—is all important, it is useful to see what is intended by that training. Referring to The Book of Analysis,⁹ it says:

“Therein what is right effort? Herein a Bhikkhu engenders wish, makes effort, arouses energy, exerts the mind, strives for the non-arising of evil bad states that have not (already) arisen ... strives for the abandoning of evil bad states that have arisen ... strives for the arising of good states that have not (already) arisen ... strives for the stabilizing, for the collocation, for the increase, for the maturity, for the development, for the completion of good states that have arisen. This is called right effort.”

From this it can readily be appreciated that striving for the non-arising and for the abandoning of evil bad states is a fundamental of proper practice, because these are the lowest, the most harmful, the most dangerous, and the most inhibiting to forward progress. Because of this, to

⁷ See chart 3.

⁸ See Book of Analysis (translation of Vibhaṅgapali, P.T.S. 1969, p. 515, par. 984).

⁹ P. 309, par. 487.

define them before any others is the initial task of Abhidhammatthasaṅgaha, and it is in verse four that this is done.

VERSE 4

66.¹⁰ Being the opening statement of INTEGRAL STATES CHARACTERISTIC OF THE PLANE OF SENSE DESIRE (*kāmāvacara cittāni*) the verse opens with the question quoted earlier:

TATTHA KATAMAM KĀMĀVACARAM

Of which the translation is repeated:

WHICH (*katama*) OF THESE (*tattha*) are CHARACTERISTIC OF THE PLANE OF SENSE DESIRE (*kāmāvacara*)?

67.¹¹ Following this, comes the actual first statement of Integral States, of which the initial category is of those rooted in GREED (*lobha*). The Pāli is as follows:

SOMANASSA-SAHAGATAM DITTHIGATA-SAMPAYUTTAM
ASANKHĀRIKAM-EKAM (1) SASANKHĀRIKAM-EKAM (2)
SOMANASSA SAHAGATAM DITTHIGATA VIPPAYUTTAM
SANKHĀRIKAM-EKAM (3) SASANKHĀRIKAM-EKAM (4)

UPEKKHĀ-SAHAGATAM DITTHIGATA-SAMPAYUTTAM
ASANKHĀRIKAM EKAM (5) SASANKHĀRIKAM EKAM (6)
UPEKKHĀ-SAHAGATAM DITTHIGATA-VIPPAYUTTAM
ASANKHĀRIKAM EKAM (7) SASANKHĀRIKAM-EKAN-TI (8)
IMĀNI ATTHA-PI LOBHA-SAHAGATA-CITTĀNI NĀMA

68.¹² Which means:

There are two greedy integral states wherein factorial consciousness is:

ACCOMPANIED BY (*sahagata*) MENTAL PLEASURE (*somanassa*) and ASSOCIATED WITH (*sampayutta*) WRONG VIEW (*diṭṭhi-gata*) of which ONE (*eka*) is UNINSTIGATED (*asaṅkhārika*) and ONE (*eka*) is INSTIGATED (*asaṅkhārika*);

Also two

ACCOMPANIED BY (*sahagata*) MENTAL PLEASURE (*somanassa*) but DISSOCIATED FROM (*vippayutta*) WRONG VIEW (*dijjhi-gata*) of which ONE (*eka*) is UNINSTIGATED (*asaṅkhārika*) and ONE (*eka*) is INSTIGATED (*asaṅkhārika*);

Then two

ACCOMPANIED BY (*sahagata*) NEUTRAL (*upekkhā*) feeling, and ASSOCIATED WITH (*sampayutta*) WRONG VIEW (*diṭṭhi-gata*) of which ONE (*eka*) is UNINSTIGATED (*asaṅkhārika*) and ONE (*eka*) is INSTIGATED (*asaṅkhārika*);

Finally two

ACCOMPANIED BY (*sahagata*) NEUTRAL (*upekkhā*) feeling, but DISSOCIATED FROM (*vippayutta*) WRONG VIEW (*diṭṭhi-gata*) of which ONE (*eka*) is UNINSTIGATED (*asaṅkhārika*) and ONE (*eka*) is INSTIGATED (*asaṅkhārika*). THESE (*imāni*) EIGHT TOGETHER (*attha pi*) ARE

¹⁰ See Chart No. 4.

¹¹ See chart 4.

¹² See chart 4.

KNOWN AS (*nāma*) Factorial CONSCIOUSNESS ACCOMPANIED BY GREED (*lobha-sahagata-cittāni*).

GREED (*lobha*).

69. Within these eight types of greedy integral states it can be seen that greed is the one quality which each individual state has in common with the others; which is the root from which all stem; which supports and nourishes them and is the cause of their becoming great and producing plentiful fruit. In what way therefore can greed itself be described? In *Dhammasaṅgaṇī*¹³ the basic description is very simple and straightforward:

"Greed, being greedy, state of being greedy, infatuation, being infatuated, state of being infatuated, covetousness, the bad root of greed."

This, however, gives a rather unsubtle view of a very important root condition, in as much as from the terms used it would appear to describe only its baser aspects. Later in the same work, though,¹⁴ and in *Vibhaṅga*,¹⁵ a much more extensive list is given wherein there are more than one hundred synonyms, thereby clearly demonstrating the wide range of meaning to be included within that single word. Here are some extracts from that list: "Greed is that which is seduction, yearning, hankering, wishing, imploring, clinging, intimacy, fondness, wanting sights, sounds, odours, savours, tangibles, wanting sons, wanting life, self-indulgence, desire for the nicer, liking, craving for becoming, craving for non-becoming ..."

70. That is a statement of allied qualities, all of which in an ultimate sense are greed. What the list does not show, though, is that each separate item is able to be exerted from the slightest, most tentative degree, to the most overwhelming flood of lust, passion, and avarice, sweeping all before it to gain its greedy goal. The words "greed" and "lust" have a connotation suggesting nothing but power and violence; this is so, but it should at all times be appreciated that this same greed and lust can appear in an utterly different guise. It can be subtle, pleasing, delicate, tender, refined and gentle, it can appear sympathetic and compassionate, but beneath its external form striving always, in one way or another, to satisfy its fundamentally grasping nature.

71. The Buddha himself once said:¹⁶

"Bhikkhus, I know of no other single thing of such power in causing the arising of wish for sense pleasure that has not already arisen, or causing the becoming more or increase of sense pleasure that has arisen, than the feature of beauty in things."

The Buddha also said:¹⁷ "I know of no other single thing as intractable as the untrained mind. The untrained mind is indeed an intractable thing."

72. Bearing in mind both these extracts from the Suttas, it is apparent that two things are of great and continuing importance. First of all is the need to be aware of, and to be able to recognize, the nature of greedy states, not only when they have already arisen in oneself but also when they are liable to arise. The second is that the mind should be trained in its way of working so that it may become tractable and thereby capable of being correctly orientated, not

¹³ See also *Buddhist Psychological Ethics*, p. 94, par. 389.

¹⁴ See also *Buddhist Psychological Ethics*, p. 254, par. 1059.

¹⁵ *Book of Analysis*, par. 909.

¹⁶ *Āṅguttara Nikāya*, Sutta No. 2, *Gradual Sayings*, Vol. 1, p. 2.

¹⁷ In Sutta No. 4 of the same collection.

only to the recognition and elimination of bad unskilful states, but to the stimulation and support of states that are skilful and good.

73. The study of Abhidhamma is a precise and comprehensible method by which knowledge of all such states can come to be known, and how the workings of the mind take place. Armed with such knowledge, its application, and practice is the purpose of the Buddha's exhortation later in the two Suttas just quoted.

74. Regarding greed itself, the Commentary¹⁸ shows its General Characteristic to be the cleaving to an object of sense in the manner of the stickiness of a spider's web; its inherent functional property as adhering like a slice of meat thrown into a hot frying pan; its Resultant Appearance being that of not letting go, like the taint, colour or stain of lamp black; its Concurrent Footing, the seeing of enjoyment in states connected with fetters.

75.¹⁹ While dealing with the bad root of greed it is important to appreciate that, as with all bad unskilful states, it is not only from the root by which they are known and named that they arise, but from the root of DELUSION (*moha*) also. Greed cannot act by itself, it can do so only in the presence of dullness, ignorance, and delusion. It is the activity of delusion that is detectable in the very presence of WRONG VIEW (*diṭṭhi*). The truly basic root of evil, the father of all bad states, is indeed IGNORANCE (*avijjā*), but here manifesting itself as DULLNESS and DELUSION (*moha*). Its General Characteristic is that of be mentally blind, of opposition to knowledge. From this can be deduced its inherent functional property is an absence of penetration, and of obscuration of the true nature of an object. This again is demonstrated in its Resultant Appearance as an absence of right practice, conduct, or disposition, of mental blindness, darkness, and bewilderment. All of which qualities, from the General Characteristic onwards, being based upon its Concurrent Footing of improper attention to what is right, correct, or ultimate truth.

76. Returning now to the complete collection of greedy states, wherein the text details a total of eight, four being accompanied by feelings of mental pleasure, four by neutral feeling, and where, within both groups of four, two are associated with wrong view and two dissociated from wrong view. It will have been noticed during the detailing of those states that certain additional qualifying terms have appeared, terms such as WRONG VIEW (*diṭṭhi-gata*), UNINSTIGATED and INSTIGATED (*asaṅkharika*, *sasaṅkhārika*). These are new words, each of which needs some explanation; this will be given, but first, before discussing them, a few words need to be said about FEELING (*vedanā*), because feeling is, without exception, present in every integral state.

FEELING (vedanā)

77. In Integral States Characteristic of the Plane of Sense Desire the nature of feeling is categorized as being of five kinds, distinct gradings which do not overlap each other. They are:

- 1) Bodily PLEASURE (*sukha*), including all forms of bodily pleasure, comfort, and ease.
- 2) Bodily PAIN (*dukkha*), comprising all aspects of bodily pain, discomfort, or uneasiness.
- 3) MENTAL PLEASURE (*somanassa*), including all forms of mental pleasure, happiness, joy, and ease.
- 4) MENTAL PAIN (*domanassa*), comprising all aspects of mental pain, displeasure, unhappiness, sorrow, and uneasiness.

¹⁸ See also Expositor, p. 332.

¹⁹ See chart 3.

5) (Hedonic) NEUTRALITY or INDIFFERENCE (*upekkhā*), being the midpoint between pain and pleasure.

78. A point of which to be especially careful when using this English word "feeling" in a Buddhist context is to appreciate that it is being made use of merely as a near equivalent for the Pali word "vedanā" and must therefore be thought of and used only in terms of the fivefold group just given. It should never include the alternative usages so frequently employed in English wherein it refers to aspects of emotion, sentiment, affection, sympathy, or tenderness. These latter, in Buddhist terminology, are never directly associated with the word "vedanā," they have their own special words, several of which will be encountered later on. "Feeling," therefore, refers only to pleasant, painful, or neutral feeling as it arises in connection with mental or physical states.

79. To digress for a moment or two in order to return to the uncertainties experienced in searching for really suitable English equivalents for Pāli words. Equivalents are rarely exact, but there is one way of overcoming the difficulty which is much to be recommended. It is to make frequent and regular use of the Pāli words themselves. In this way one gradually builds up a personal vocabulary in which the connotations are purely Buddhist, and not coloured by any background of customary Western usage. Thus one would then think naturally of "vedanā" with its five categories, rather than of "feeling."

Talk Two (Part Two)

80. Returning again to the five types of feeling, the meanings of the first four are quite straightforward; the fifth, though, here called "neutral," does need some additional explanation, but this time because of the difficulty of finding a really suitable equivalent for the Pāli term "upekkhā." In the present context the idea it is intended to convey in "neither-painful-nor-pleasant," an almost literal translation of the Pali "*adukkham-asukha*" Throughout the texts of Abhidhammatthasaṅgaha this latter is a term used very frequently to express the nature of feeling experienced at that point which is precisely midway between being just painful or just pleasant. It is an aspect of feeling wherein, however carefully it is examined, it cannot be said to be either unpleasant or pleasant; a-dukkha, meaning "not-pain;" a-sukha, meaning "not-pleasant."

81. Sometimes "upekkhā" is rendered "indifference," sometimes "hedonic indifference;" the inclusion of "hedonic"—in its psychological sense of dealing with both pain and pleasure—being very suitable where it is coupled with "indifference" as it emphasizes this direct association with pain and pleasure. However, the two words together are rather long and do not combine well when FEELING (*vedanā*) has also to be used; so except when it is particularly necessary to emphasize the pain and pleasure aspect, "neutral" or "neutrality" is employed here, but with the proviso that it be understood as meaning "hedonically neutral" or "hedonic neutrality."

82. But to continue with an explanation of meanings of new words. The expressions ASSOCIATED WITH WRONG VIEW (*diṭṭhi-gata-sampayutta*) and DISSOCIATED FROM WRONG VIEW (*diṭṭhi-gata-vippayutta*) are manifestly closely associated, for although as terms they are mutually exclusive the integral states in which they occur both arise in connection with the BAD ROOT OF GREED (*lobho-akusala-hetu*). There are, however, very different reasons for their occurrence. Put in an elementary way these differences lie basically in the level of knowledge and understanding of the individual.

83. In the case of "associated with wrong view," action will be performed almost automatically with the arising of a greedy wish. Although such action is fundamentally morally bad, the doer will not look upon it in this way because of the overwhelming nature of his ignorance. His appreciation of any difference between bad and good will be so muddled and deluded as to utterly preclude any abstention from the performance of a deed that is in accord with his greedy wish.

84. The case of "dissociated from wrong view" is quite different, because here the doer knows very well that the greedy wish is both bad and unskillful, and will produce unhelpful resultant that will retard his progress upward in the scale of advancement. Despite this, though, because of the strength of his wish to enjoy, or his desire for the approbation of others, his personal conceit will override any such thoughtful considerations and will seek some justification for performance of the action. Where greed is present but wrong view is not, another factor takes its place and will be explained shortly; nevertheless, because of DELUSION (*moha*) his thought is still dull but differently so from one who is obsessed by completely wrong view. But now to examine the terms a little more closely.

WRONG VIEW (*diṭṭhi-gata*)

85. The Pāli word "diṭṭhi-gata," customarily translated "wrong view," means more literally RESORTING (*gata*) to WRONG VIEW (*diṭṭhi*). Strictly speaking "diṭṭhi" means just "view;" when, though, it is used by itself without either prefix or suffix, it is usually understood to be

“Wrong View” as opposed to RIGHT VIEW (*sammā-ditṭhi*). In the way in which it is used in connection with greed it refers to any kind of opinion based upon which there seems to be justification for thought, speech, or action, accompanied by greed, to take place. This is more subtle than would appear at first sight; for when it is appreciated that here it is a question of WRONG VIEW (*ditṭhi*) as opposed to RIGHT VIEW (*sammā-ditṭhi*), where right view in its ultimate sense means seeing things as they really are, it infers that in this absence of any proper comprehension of the THREE CHARACTERISTICS: IMPERMANENCE, UNSATISFACTORINESS and ABSENCE OF SOUL (*ti-lakkhana: anicca, dukkha, anattā*) a very high proportion of one’s thought, speech and action is by definition firmly rooted in GREED (*lobha*), and is therefore manifestly UNSKILFUL (*akusala*).

86. An explanation taken from the Commentary²⁰ is that the origin of “wrong view” lies in the hearing of incorrect doctrines, having unsuitable friends, a lack of desire to see NOBLE ONES (*ariyā*) and improper attention to what is right. Examining “wrong view” when isolated from other considerations it is seen to possess four specific qualities: the General Characteristic of IMPROPER INCLINATION (*ayoniso abhinivesa*); the inherent functional property of PERVERSION (*parāmāsa*); the Resultant Appearance of FALSE CONVICTION (*micchā abhinivesa*) and the Concurrent Footing of LACK OF DESIRE TO SEE NOBLE ONES (*ariyanam adassana-kamata*).

DISSOCIATION FROM WRONG VIEW, CONCEIT (*ditṭhigatavippayutta, māna*).

87.²¹ As has already been seen and to some extent discussed, greedy integral states do not always arise in association with wrong view, for there are those persons who are quite without the view of there being any permanent self or soul, and yet who perform actions which are clearly rooted in greed. The Commentary,²² still speaking of wrong view, says it should be looked upon as the highest fault. This is not said lightly and just on account of its being associated with greed, but because in such greedy states there occurs this particular additional concomitant feature: a complete lack of understanding of the true nature of things. This itself is, indeed, the highest fault, and when coupled with greed forms the most undesirable combination. Where such fault is not present, i.e., in states dissociated from wrong view, it means that the being concerned is not influenced by incorrect doctrines, unsuitable friends or by lack of desire to see Noble Ones, consequently greed does not arise in association with views drawn from such sources, but is differently based. It arises largely because of the wish for existence and the pleasure which occurs purely by way of sense experience, i.e., delight in pleasant sights, sounds, scents, flavours, tangibles and ideas. As such it is to be regarded as greed based on vain imaginings as to the desirability and appropriateness of sense pleasure, and this, moreover, in the face of an actual understanding of their true nature. To act in such a way is clearly unskilful, but it can at least be said not to be influenced by wrong view. By what then is it influenced?

88.²³ If a person stimulates greed in a manner contrary to his knowledge of truth, it occurs for two reasons. First, is vain imagining; second, an exaggerated opinion of himself. The English word which includes both these meanings is CONCEIT (*māna*), and it is this that is present when greed arises dissociated from wrong view. Its General Characteristic is LOFTINESS (*unnati*), that is, “holding oneself above proper considerations;” with the quality of SELF-PATRONAGE

²⁰ See also Expositor, pp. 330-336.

²¹ See chart 4.

²² Expositor, p. 331.

²³ See chart 4.

(*sampaggāha*) as its Inherent Functional Property; the Resultant Appearance of SELF-ADVERTISEMENT (*ketukamyata*), with all three having their Concurrent Footing in the existence of GREED UNACCOMPANIED BY WRONG VIEW (*diṭṭhi-vippayutta-lobha*). Basically "conceit" is considered as a form of MADNESS or MENTAL ABERRATION (*ummada*).²⁴

GENERAL CHARACTERISTIC, ETC. (*lakkhan adi*)

89.²⁵ It will have been noticed in the course of explaining the meanings of the several preceding terms that four particular methods of describing their attributes have been used, they are:

General Characteristic.
Inherent Functional Property.
Resultant Appearance.
Concurrent Footing.

Strictly speaking these four are not specifically mentioned until chapter nine of Abhidhammatthasaṅgaha; however, as a method of showing the main features of individual states they are in general use throughout the Commentaries, and occur in much earlier works such as Nettipakaraṇa. They are of great help towards gaining an understanding of the nature of states, and often of distinguishing between them, so it is useful to examine their mode of inquiry.

GENERAL CHARACTERISTIC (*lakkhana*).

90.²⁶ This is the primary sign or feature, the most elementary distinguishing mark by which the particular state may be recognized. It displays the GENERAL NATURE (*samanna-sabhāvo*) of that state in its most simple form. It is known as "lakkhana" and is here translated as GENERAL CHARACTERISTIC; it is also frequently known just as "Characteristic."

INHERENT FUNCTIONAL PROPERTY (*rasa*).

91.²⁷ This shows the unique innate attribute of the state, rather as the intrinsic flavour of a substance might be described as being either salt, sweet or sour; as the active principle in a herb or plant might be pointed out, or as the property of a particular medicine might be specified as being either purgative or soothing. It is known as "rasa" (lit. "flavour"), and is here translated as INHERENT FUNCTIONAL PROPERTY, It is often known as "function."

RESULTANT APPEARANCE (*paccupajjhāna*).

92.²⁸ This attribute is a resultant, or fruition, and represents the manner in which the inherent functional property manifests itself to become apparent to an observer. It demonstrates the fully mature appearance of the state as contrasted with its simple General Characteristic. From this appearance being due to its resultant origin it is known as "paccupaṭṭhāna" (lit. reappearance), and is here translated as RESULTANT APPEARANCE. It is often known as "manifestation."

²⁴ Expositor, p. 340.

²⁵ See chart 5.

²⁶ See chart 5.

²⁷ See chart 5.

²⁸ See chart 5.

CONCURRENT FOOTING (*padatthāna*).

93.²⁹ This final attribute is the ground structure upon which stand the three preceding qualities. It is frequently known as "Proximate Cause." However, since "proximate" has a more or less sequential connotation, the incorrect impression can be created of an immediately preceding condition, whereas being an actual attribute of the very state in question it should be looked upon as occurring together with the other three. Nor can it be said to be a cause in the true sense, but should rather be thought of as the starting point, the basis, the standing ground, the floor, that upon which the others stand and are supported, much as the wall of a house is supported by its footing and could not be erected without it. "*Padatthana*" means literally "a foot place, or footing," and although "footing" is a rather clumsy word for philosophical use it has seemed, in view of its meaning, the most suitable to use here. Nevertheless, to give it the sense of being co-existent and taking effect with the other three, yet even so being their standing ground, it is here translated as CONCURRENT FOOTING.

UNINSTIGATED, INSTIGATED (*asañkhārika, saañkhārika*).

94 Reverting now to the translation of the text to make a short note on the difference between greedy integral states designated as UNINSTIGATED (*asañkhārika*) and INSTIGATED (*sasañkhārika*). How should this difference be interpreted? In this instance the meaning of "*sañkharika*" has to do with the making of effort or EXERTION (*sappayoga*), or of having a plan, method or way of doing, of strategy or EXPEDIENCY (*saupaya*). From this, two things emerge; first that UNINSTIGATED (*asañkharika*) must therefore mean without effort, exertion, expedience or special plan; second that INSTIGATED (*sa-sañkherika*) will consequently mean with effort, exertion, expedience or special plan.

95. Reducing these explanations to the way in which things operate in practice, it shows that if an action is uninstigated it is performed quite voluntarily, that is, entirely on one's own volition, without hesitation and without instigation or prompting; it is an action entirely personal and self-originated. On the other hand, if it is instigated the action is not completely voluntary, there is hesitation so that either special self-effort or self-instigation has to be made from there being some secondary reason or stimulation; or, alternatively, there is the need for external instigation or prompting. Not a great distinction between these two, but, as will be seen in a later chapter, one necessitating a slight difference in structural make-up.

FACTORIAL CONSCIOUSNESS (*citta*).

96. In concluding what has been said about greedy states it would be well to return to the most important component quality of all, consciousness; on this occasion, though, to consider it in its purely ultimate sense as factorial consciousness. So far, in dealing with the eight types of greed, the consideration has been of integral states; however, it should not be forgotten that the expressions "integral states" and "integral consciousness" have been adopted largely for the purpose of examining complex mental states wherein so-called "factorial consciousness" is acting together with certain additional factors called "mental concomitants," a combination which is expressed by the Pāli term "*citta-cetasikā-dhamma*." It is also being used for the specific purpose of differentiating between those complex states and that which is just basic awareness, the single property of having thought of an object, of being conscious of that object. As explained at an earlier stage,³⁰ basic awareness, FACTORIAL CONSCIOUSNESS (*citta*) is one of

²⁹ See chart 5.

³⁰ See pars. 40 & 45.

the FOUR ULTIMATES (*catu paramattha*³¹), and is the innate constituent of every INTEGRAL STATE (*citta-cetasika-dhamma*). It is axiomatic to say that no mental concomitant arises without the presence of consciousness. The Commentary³² gives its General Characteristic as AWARENESS (*vijānana*), its inherent functional property as GOING BEFORE, LEADING, of being FOREMOST (*pubbaṅgama*), its Resultant Appearance as CONNECTING (*sandahana*), and the Concurrent Footing as MENTAL AND MATERIAL QUALITIES (*nāma-rūpa*).

97. Consequently, where there is to be the examination of an integral state the primary constituent to be borne in mind is factorial consciousness, because from the statement of its General Characteristic as “awareness” a quality is thereby declared which is clearly intrinsic to every integral state also. Awareness of its object is the dominant feature of any conscious state, whatever its attendant qualities may be.

98. To establish even more strongly this dominant position, the inherent functional property should also be studied. “Going before, leading and being foremost” are not meant with reference to time, but in the sense of factorial consciousness having the attendant qualities around it and being chief among them so that they arise when it arises, are present when it is present and cease when it ceases. Among them consciousness is foremost, and in the sense that it dominates them is their chief; moreover, inasmuch as they cannot arise or function without it, they are originated by consciousness. Here it is worth noting that the opening words of Dhammapada are a direct statement of the inherent functional property of consciousness: “*Mano-pubbaṅgama dhammā: mano-setthā mano-maya.*”

99. To recognize the implications of “connecting” as the resultant appearance, or manner in which consciousness can be observed to operate, is of supreme importance to the serious student of Buddhist Teaching. Why is this so? In the course of existence beings tend to look upon consciousness as a permanent enduring thing, they are confused, and being filled with WRONG VIEW (*diṭṭhi*) think: “The essential me is consciousness; when at death I am separated from my body it is consciousness that will go on because it is the self that endures and will continue to enjoy the pleasures of the next world.” As their training and knowledge of the nature of phenomena develops, they learn that consciousness is not an enduring thing but consists of nothing more than a dependently associated series of separate momentary states, individually coming to be and passing away in rapid succession from the instant of conception to the moment of death. However, because of the presence of their continued and powerful CRAVING FOR EXISTENCE (*bhava-tanhā*), even the possession of such knowledge does not necessarily quell their great doubt and uncertainty, and on this account there is frequent rejection of that knowledge as being truth. When, though, through hard practice directed to the gaining of understanding, that knowledge is transcended and becomes penetrative insight, it is then that this knowledge of “connecting” as the resultant appearance of consciousness is fully comprehended and becomes a basis for true realization of the THREE CHARACTERISTICS: IMPERMANENCE, UNSATISFACTORINESS and ABSENCE OF SOUL (*ti-lakkhana anicca, dukkha, anattā*).

100. Consequently, to grasp the significance of this feature of “connecting” as it occurs linking the serial instants of consciousness, so that they appear to flow like a river, is indeed very important, because quite apart from any ultimate realization of the true nature of things it is some small understanding of this very “connecting” that can on occasions give to a person his first intimation that consciousness is not what it has seemed to be, something permanent and

³¹ See Chart No. 2.

³² Expositor, p. 148.

enduring, but that it is a phenomenon, momentary and fleeting, and is therefore not tenable as a solid and lasting basis to be grasped after,

101. What is it that is important to take notice of when considering the Concurrent Footing upon which the preceding qualities stand? It is to observe that when, as in the case of factorial consciousness this footing is stated to be MENTAL AND MATERIAL QUALITIES (*nāma-rūpa*), it is referring to the basic principle that consciousness, whether considered as factorial or integral, can come to be only provided there is a suitable object of which it can be conscious. If that object be a MATERIAL QUALITY (*rūpa*) it is to be understood that consciousness is caused to arise, takes as its object either something that has the property of being visible, or of being audible, of being odiferous, sapid or tangible, meaning that as an object it is a quality cognizable only by way of one or other of the five organs, or doors, of sense. If the object be a MENTAL QUALITY (*nāma*), consciousness takes it not through the five doors of physical sense but as an ideational impression arising by way of the so-called mind door. Thus in these ways it is to be seen that only by participation of one or other of the six avenues can consciousness ever be caused to arise. What then is to be learned from this?

102. It is that it should be recognized as demonstrating our own basic condition, or predicament; that of existing as beings in a state of which it is said "CONSCIOUSNESS IS CHARACTERISTIC OF THE PLANE OF SENSE DESIRE (*kāmāvacara citta*)."
It is a condition wherein CRAVING (*tanhā*) grasps incessantly after mental and material objects as its nutriment, where it is unceasingly fed and where in return, but strictly in accordance with that process, it maintains us in the constant round of existence and rebirth. It is there that we shall remain until properly directed effort is made towards release. Such is the work of craving, so strongly embodied in greedy states, and where it shows itself in its least subtle form as the BAD ROOT OF GREED (*akusala-lobha-mūla*). Greed, and therefore craving, is exceedingly difficult to conquer, but the Buddha in two short verses has given a key to the practice to be followed. They are Nos. 360 and 361 of Dhammapada, and as a guide are very straightforward and therefore most valuable to commit to memory.

103. "With the eye restraint is good,
Good is restraint with the ear,
With the nose restraint is good,
Good is restraint with the tongue.
With the body restraint is good,
Good is restraint with speech,
With the mind restraint is good,
Good is restraint throughout all.
The Bhikkhu restrained in all ways from every sorrow is freed."

Talk Three (Part One)

104. Before proceeding with a description of the second group of BAD STATES (*akusala dhamma*), comprising those arising from the BAD ROOT OF HATRED (*dosa-akusala-hetu*), some further points concerning the way in which greedy states come to be should first be mentioned. The reason for this is to make apparent certain laws, and show that although in their outward behaviour greed and hatred appear very different from each other, closer examination shows that the background from which each ultimately arises is indeed the same, as is the case for many other states also.

105. Previously it has been said that restraint is good, not only in respect of the five doors of sense, but of the mind door also. Why is restraint good? Why should not all the six senses (five physical plus ideational) be given free rein and thereby take in impressions from every possible field? Can it not be said that to exercise such complete freedom and absence of restraint is the very way by which a full and enjoyable life is to be realized, a life quite untrammelled by restriction and thereby capable of self-expression to its most lavish degree? At first sight this attitude may well appear to be correct; moreover, it is the one acceptable to many, in fact to a greater or lesser degree by the vast majority of beings. Indeed, it might even well seem to be a reasonable attitude to take but for the single principle which stands quite in the way of its being a valid course to follow. The Buddha taught that nothing in this conditioned existence happens other than by way of cause. This is axiomatic, and examination will show that because of its being so, all qualities, mental and material, are in one way or another causally related to each other.

CAUSALITY

106. In mode of operation a causal relationship of this kind is neither sporadic nor of a random nature; on the contrary, it behaves in a regular and strictly serial manner wherein every class of activity produces its own especial and perfectly natural resultant condition. In this particular case, though, because of the very nature of the resultant itself, it possesses the innate property of then functioning as an origin or cause, the outcome of which is a yet further resultant condition having this same quality of then manifesting itself as a cause. Such a type of activity can clearly become a continuous series, something that can go on and on. This is truly so, and, because of the close interconnection and specific relationship between the elements of the series, it constitutes a law so fundamental that it may be said to be the very groundwork or pattern of existence.

DEPENDENT ORIGINATION

107. In its entirety this law of THE ARISING OF RESULT DEPENDING ON A CAUSE (*paṭiccasamuppāda*) is deep, subtle, complex, and difficult to comprehend, but since, as a separate subject, it is not introduced formally until the eighth chapter of Abhidhammatthasaṅgaha it cannot therefore be discussed here in detail. In spite of this, though, certain aspects are of particular relevance to that which occurs when the five physical senses and mind are unrestrained; consequently it can to some limited extent be considered at this juncture, particularly in view of its being of paramount importance to those who would wish to gain some control over the means by which the course of their existence is otherwise invariably directed.

108. When, in the case of greedy integral states, an object that is to prove desirable presents itself within the field of activity of the six organs or BASES OF SENSE (*salāyatana*), then, according to whether that object is visible or audible, odiferous or sapid, tangible or ideational, the appropriate BASE (*āyatana*) will receive a stimulus. Provided that at that instant the attendant conditions are suitable, and as the result of the presence of that stimulus at the appropriate base there is the arising of consciousness, it is then said that CONTACT (*phassa*) has taken place between the ORGAN OF SENSE (*āyatana*), consciousness, and the OBJECT (*ārammana*).

109. Stating such a relationship the Buddha said, "BECAUSE OF THE SIX BASES CONTACT ARISES (*salāyatana-paccaya-phasso [sambhavati]*).³³"

110. Putting on one side for the time being any analysis of the actual working structure of the course of CONSCIOUS PROCESS (*citta-vīthi*) that takes place following the moment of contact, the immediate outcome is that because of a recognition of the General Characteristic of the object, it will, before anything else, be experienced in terms of feeling that is either pleasant, unpleasant or hedonically neutral.

111. In order to show the causal connection between contact and feeling the Buddha said, "BECAUSE OF CONTACT FEELING ARISES (*phassa-paccaya-vedanā-sambhavati*).³⁴"

112. Let's consider now this last occurrence, purely from the point of view of greed. If the object was recognized with pleasure it can very naturally be inferred that, in a conventional sense, it was likeable or attractive; here, though, in the deeper sense of Abhidhamma teaching it should be observed that it is not the object itself that is liked or considered attractive, but only the pleasurable feeling that arises consequent upon its presence. Conventionally a material object may be said to be beautiful; intrinsically, though, it possesses no such quality. On the other hand, beings seek almost all the time for the experience of pleasure in one form or another, whether by way of the five physical senses or the mind. This is due to the presence of the root characteristic of GREED (*lobha*) and to that of the even more universal and fundamental quality, CRAVING (*tanhā*), and because of its presence when pleasure is experienced, there arises immediately the desire, the strong desire, the greed, the craving for more.

113. In using the word "craving" as an equivalent for "*tanhā*" it is looked upon by many as a term much too harsh for the outcome of so simple a state as feeling, and this is particularly so among those who hear it for the first time and are therefore not familiar with its usage. One of the meanings of *tanhā* is thirst. Where thirst exists it proclaims itself as anything from a slight dryness of the throat to a severely parched condition of the body. Both of these states and anything in between are temporarily assuaged by water; so whether as the result of moderately unpleasant dryness one says, "I should like a drop of water," or in the agony of the last stages of dehydration, with swollen tongue and cracked lips, one croaks, "Water," we use the single word "thirst." In like manner, where by way of the five senses and mind there has been deprivation of the water—or rather, in Buddhist terminology, of the FOOD (*āhāra*)³⁵ of contact—and thereby of any such outcome as pleasant feeling, there arises a "thirst," slight or violent according to the nature and magnitude of that deprivation. As a being thirsts for water, so also does *tanhā* thirst for the arising of pleasant feeling. Under these latter circumstances, though, the word "thirst" is not usually considered quite appropriate for use as a technical term; however, provided always

³³ Sutta 1 of Nidānaṣaṃyutta, Kindred Sayings Vol. II; also Vibhaṅgapāli, paṭiccasamuppādavibhaṅga, The Book of Analysis, par. 225.

³⁴ Same refs. as previously.

³⁵ In Buddhist Teaching, CONTACT (*phassa*) is grouped as one of the four NUTRIENTS (*āhāra*).

that the breadth of application of thirst is fully appreciated, its alternative, craving, can as a general term very well fit the meaning of *tanhā*.

114. Proclaiming the relationship between feeling and craving the Buddha said, "BECAUSE OF FEELING CRAVING ARISES (*vedanā-paccaya-tanhā [sambhavati]*).³⁶"

115. If craving is that which everlastingly hankers after pleasant feeling, and is thereby always intent upon gathering—like a greedy mouth ever taking in food, and bent upon nothing but the sweet and toothsome—is this the end to which all such activity is directed? In one sense yes; for craving, arising out of and being co-existent with IGNORANCE (*avijjā*), with its absence of knowledge of the true nature of things, is completely oblivious of the SUFFERING (*dukkha*) which results from its activity. In another sense the answer is very clearly no; for that which craving hankers to obtain, ATTACHMENT (*upādāna*) strives to retain. Craving is, as it were, the hand that stretches out to receive; attachment the hand that closes to keep.

116. In teaching the connection between these two the Buddha said, "BECAUSE OF CRAVING ATTACHMENT ARISES (*tanhā-paccayā-upādānam [samchavati]*).³⁷"

117. It has been said that ATTACHMENT (*upādāna*) arises in respect of the pleasant feeling that CRAVING (*tanhā*) ever seeks to enjoy. It is much more than that, though, for attachment seeks not only to retain such pleasure, but also the object thought to have been its cause. Attachment, however, despite its having been compared with the closing of the hand, which as craving was open and reaching out, is as it stands just an attitude, a potential condition, one as yet unmanifest as direct action. What then is the outcome of such potentiality, how does it become manifest?

118. If there is attachment with regard to an object, there follows as a natural outcome MENTAL ACTION (*mano-kamma*); that is, positive thought about how to obtain or retain the object. Following such thought arises VERBAL ACTION (*vāci-kamma*) and BODILY ACTION (*kāya-kamma*) directed specifically towards that obtaining or retaining. Thus there will be seeking, pleading and cajoling; opposition, deceit, aggression and every kind of unskillful, BAD ACTION (*akusala-kamma*) which at that time is considered appropriate to the attaining of one's end. However, because of the ever operative law of causality, THE ARISING OF RESULT DEPENDING ON A CAUSE (*paṭiccasamuppāda*), mental, verbal, or bodily action directed to some such end invariably produces an outcome that reflects directly back upon the doer.

119. Stated very briefly and without detail, such outcome strengthens not only the tendency towards repetition of the type of state that produced it, but also a different and still stronger potentiality, one directed towards perpetuation of the doer himself, as is represented in that whole continuity of process we call existence.

120. To find a single English word capable of expressing properly the seemingly dual nature of this "potentiality" would indeed be difficult, for in effect the need would be, first to indicate the heaping up of that potentiality in the form of "resultant of action," then to show that very resultant manifesting itself as a potentiality or "tendency towards rebirth" in the one responsible for the action. From this it may be seen that whereas its initial aspect is that of "action cumulative of resultant," it manifests as "resultant tending towards rebirth." Combining these two aspects as the single phrase "action cumulative of resultant tending towards rebirth" attempts to show the composite meaning of that next step of which ATTACHMENT (*upādāna*) is the immediate cause. In spite of the difficulty, though, of finding a single English word for this

³⁶ Same refs. as previously.

³⁷ Same refs. as previously.

stage in the causal series, the Pāli word “*bhava*” when applied in its technical sense has just such a connotation.

121. Basically, in dictionary translation, “*bhava*” means, “being, existing, increasing or becoming,” and in the context of the causal series it is that final term “becoming” which in translation is customarily employed to express the condition of “tendency towards rebirth.” However, in its position of following attachment its purpose is to represent the two aspects of becoming, i.e., ACTION CUMULATIVE OF RESULTANT (*kamma-bhava*) and RESULTANT TENDING TOWARDS REBIRTH (*upāpatti-bhava*). BECOMING (*bhava*), therefore, however inadequate it may seem as a word describing such a complex condition, is at least a literal translation of the Pāli, and until something more suitable can be suggested it is the single term by which both these aspects are represented. In the context of the causal series, therefore, it should be understood as meaning, “action as the result of which there is a heaping up of those conditions responsible for the perpetuation of the causal process;” that is, the entire causal process together with the phenomena associated with it, not just the five steps dealt with here, but in other words THE WHOLE ROUND OF CONTINUED AND RECURRENT BIRTH, AGEING AND DEATH (*saṃsāra*).

122. In formulating the relationship between attachment and becoming the Buddha said, “BECAUSE OF ATTACHMENT BECOMING ARISES (*upādāna-paccaya-bhāvo* [*sambhavati*]).³⁸”

123. For the present purpose it is not necessary to enquire either into what follows “becoming” or what preceded “contact,” the intention having been just to examine the more or less immediate outcome of contacting an object which initially gave rise to pleasant feeling.

124. Following the process through the phases of contact, feeling, craving and attachment to the point where the need to gain the object gives rise to ACTION CUMULATIVE OF RESULTANT (*kamma-bhava*), it is clear to see that the apparently simple occurrence of contacting can, even in the case of a so-called pleasant object, result not only in such greedy states as seeking, pleading and cajoling, but, with the process of gaining that object, in hateful action also; action such as opposition, deceit and aggression. All this just because of CRAVING (*tanhā*) being quite automatically followed by ATTACHMENT (*upādāna*); from which it is apparent that this most dangerous underlying condition, craving—so frequently thought of only as GREED (*lobha*)—is that from which the individual root conditions of both greed and hatred can come to be.

125. What then would have occurred if contact with the object had given rise to UNPLEASANT MENTAL FEELING (*domanassa vedanā*) instead of to PLEASANT MENTAL FEELING (*somanassa vedanā*)? Here *tanhā*—craving always and only for the pleasant—being frustrated would, still in accordance with causal law, give rise to ATTACHMENT (*upādāna*). But, bearing in mind that *upādāna* is attachment to the pleasant only, it would in effect reject the object as being undesirable so that in the ensuing phase, ACTION CUMULATIVE OF RESULTANT (*kamma-bhava*), there would because of that rejection be action removing, destroying, or otherwise operating in a manner antipathetic to the object. Thus again, by way of craving and attachment, the BAD ROOT OF HATRED (*dosa-akusala-hetu*) arises, is active, and in the natural course of the causal law, because of that BAD ACTION (*akusala kamma*), there is RESULTANT TENDING TOWARDS REBIRTH (*upāpatti-bhava*)

126. Although further investigation will not be made at this juncture, it is apparent even from the cursory examination so far made of the five stages of the causal series, ranging from

³⁸ Same refs. as previously.

CRAVING (*tanhā*) to BECOMING or ACTION CUMULATIVE OF RESULTANT TENDING TOWARDS REBIRTH (*bhava*), that important principles are involved. These principles are indeed important, so important that throughout one's study of the Teachings of the Buddha it is well for them to be borne in mind as being anchors by which to hold direction steady in the stream of understanding.

127. The first such principle to recognize from the relationships described is that nothing whatsoever in this conditioned existence occurs in a random, causeless manner, but that everything operates strictly in accordance with regular, clearly definable causal laws.

128. The second principle to realize is that this causal law pivots on, is conditioned by IGNORANCE (*avijjā*) and CRAVING (*tanhā*). How is this so? Because wherever there is craving for whatever may seem desirable, be it harmful or helpful in an ultimate sense, there arises also that quality of attachment that culminates in ACTION CUMULATIVE OF RESULTANT (*kamma-bhava*). Moreover, wherever in that action there is ignorance of the true nature of things, of SUFFERING (*dukkha*) and the CAUSE OF SUFFERING (*dukkha samudaya*), that action, be it unskillful or skillful is dominated by the ROOTS (*hetu*), each of which—good or bad—perpetuates the causal series in that second phase of becoming,³⁹ RESULTANT TENDING TOWARDS REBIRTH (*upāpatti-bhava*).

129. The third principle is possibly the most important in that it involves the practical use of restraint. It is that of realizing fully that actions performed as the direct causal outcome of lack of restraint by way of the six doors of sense are in most cases productive of harmful resultant.

130. To quote again the Buddha's words in the final lines of Dhammapada, verse 361:³⁹

"The Bhikkhu restrained in all ways
From every sorrow is freed."

131. From what has been said regarding the law defining ARISING OF RESULT DEPENDING ON A CAUSE (*paṭiccasamuppāda*), it will have been appreciated that despite the obvious differences separating GREED (*lobha*) from HATRED (*dosa*) there nevertheless exists between them a direct relationship so far as causality is concerned. In this first chapter of Abhidhammatthasaṅgaha, though, the primary purpose is not that of showing how these causal inter-relationships occur, but of making clear – by means of characteristic groupings—the root structure from which each individual integral state springs, and with which it is inseparably associated.

132. Having dealt with the eight integral states known as CONSCIOUSNESS ACCOMPANIED BY GREED (*lobha-sahagata-cittāni*), which because of their close proximity to IGNORANCE and CRAVING (*avijjā-tanhā*) are the most basic of all bad states, Abhidhammatthasaṅgaha proceeds to describe those which arise when "craving", "thirst" for pleasant feeling is not immediately satisfied. These are the states wherein there is CONSCIOUSNESS ACCOMPANIED BY HATRED (*dosa-sahagata-cittāni*), as defined in verse 5.

VERSE 5.

133.⁴⁰ DOMANASSA-SAHAGATAM PATIGHA-SAMPAYUTTAM
ASANKHĀRIKAM-EKAM SASANKHĀRIKAM-EKAN-TI
IMANI DVE-PI PATIGHA-SAMPAYUTTA-CITTĀNI NĀMA

³⁹ See above par. 103.

⁴⁰ See chart 6.

Meaning:

There are two hateful integral states wherein factorial consciousness is: ACCOMPANIED BY (*sahagata*) MENTAL DISPLEASURE (*domanassa*) and ASSOCIATED WITH (*sampayutta*) REPULSION (*paṭigha*) of which ONE (*eka*) is UNINSTIGATED (*asañkharika*) and ONE (*eka*) is INSTIGATED (*sasañkhārika*). THESE (*imāni*) TWO TOGETHER (*dve-pi*) ARE KNOWN AS (*nāma*) factorial CONSCIOUSNESS ASSOCIATED WITH REPULSION (*paṭigha-sampayutta-cittāni*). Thus it is that integral states of consciousness rooted in HATRED (*dosa*) fall into two groups.

134. In considering what has been said of the arising of both greedy and hateful integral states, and of their having an ultimate source in IGNORANCE (*avijjā*) and CRAVING (*tanhā*), to what extent in other ways may they be said to be similar, and to what degree dissimilar? Initially both can be seen in their mode of arising to be either (a) voluntary, without hesitation, unprompted and UNINSTIGATED (*asañkhārika*); or alternatively (b) by not being so, that is, in their needing in some way to be INSTIGATED (*sasañkhārika*). To this extent, then, greedy and hateful integral states are not dissimilar.

135. Secondly, both can be seen to include factorial CONSCIOUSNESS (*citta*), for factorial consciousness in being fundamental to there being awareness of the OBJECT (*ārammana*), its presence is, very naturally, the absolute prerequisite for the existence of any integral state whatsoever.⁴¹ Consequently, to this extent also, greedy and hateful integral states are not dissimilar.

136. Thirdly, it can be recognized that both classes of states include feeling. This is quite straightforward and illustrates once again their similarity, for wherever there is factorial CONSCIOUSNESS (*citta*), there, also, is FEELING (*vedanā*). Feeling, as will be seen later, though, is not only a MENTAL CONCOMITANT (*cetasika*) which, as the Commentary says, "is joined inseparably with consciousness,⁴²" but is also and at the same time one of the very building bricks, or so-called AGGREGATES (*khandhā*) of one's existence as a being; one which arises together with, is led by, is caused to be or originated by factorial consciousness which itself is also one of the AGGREGATES (*khandhā*) or essential building bricks of sentient existence. At this point, though, despite their similarity in that both are accompanied by feeling, there exists indeed a very marked dissimilarity in the actual nature of that feeling. Greedy states, as has already been seen, are accompanied either by a feeling of MENTAL PLEASURE (*somanassa*) or of NEUTRALITY (*upekkhā*). In very sharp contrast to this, hateful states are invariably accompanied by MENTAL DISPLEASURE (*domanassa*).

137. How then can mental displeasure be described? As mentioned earlier⁴³ MENTAL PAIN (*domanassa*) comprises all aspects of mental displeasure, unhappiness, sorrow, and uneasiness. It is a depressed condition wherein there is gloominess, dejection, a state of feeling dismal, glum, heavy hearted, sullen, morose, downcast, and dark. The condition may indeed be short lived and slight, as when transitory contact is made with an object which, by that individual, cannot in any way be associated with either pleasure or neutrality. On the other hand it can be long lived, as, for example, where there is the prolonged turning over and over or brooding upon some difficulty or where an aggressive or harmful matter is being contemplated. Mental displeasure is a low state, harmful in that it is associated with the BAD ROOT OF HATRED (*dosa-akusala-hetu*), consequently it is to be avoided in every possible way. Thus it is that on account of the particular types of feeling which arise, there is a characteristic demarcation

⁴¹ See par. 96.

⁴² See par. 40.

⁴³ See par. 77.

between greed and hatred. Greed can occur with pleasure or neutrality; hatred invariably with displeasure.

138. As with the many other qualities, conditions, concomitants and so on, mental displeasure is to be recognized by its own individual General Characteristic and other denotations. Thus in accordance with the Commentary⁴⁴ its General Characteristic is that of "experiencing an undesirable object." Its inherent functional property is "exploiting (or feeding upon) that undesirable aspect in one way or another." Its resultant appearance is "mental affliction (sickness or oppression)," and its concurrent footing "invariably the heart-base."⁴⁵

139. Nevertheless, to emphasize yet again the marked contrast between MENTAL DISPLEASURE (*domanassa*) born of any hateful attitude, and the pleasure that so often accompanies greedy states, the four denotations of MENTAL PLEASURE (*somanassa*) from Ven. Buddhaghosa's *Visuddhimagga*⁴⁶ are given for comparison as follows. The General Characteristic of pleasurable feeling is that of "experiencing a desirable object." Its inherent functional property is that of "exploiting (or feeding upon) that desirable aspect in one way or another." Its Resultant Appearance is "mental gratification," and its concurrent footing "calmness."

140. Thus it is that the first real difference between greed and hatred is shown by examining the feeling that arises in each in accordance with General Characteristic, etc. Nevertheless, when the terms greed and hatred are spoken of, it is not only to feeling that reference is being made but also to an obvious difference in attitude to the object at that stage where craving is succeeded by and is the cause of "wish to retain," "wish to reject" and to the actions consequent on these two attitudes. How then are greed and hatred comparable on this basis?

⁴⁴ See also Exp. p. 342 Ppn. p. 519.

⁴⁵ HEART-BASE (*hadaya-vatthu*) is not dealt with until Chap. 3 of *Abhidhammathasaṅgaha*).

⁴⁶ See Ppn. p. 519.

Talk Three (Part Two)

141. In terms of causality the fundamental difference between greed and hatred becomes most apparent at the stage where ATTACHMENT (*upādāna*), in wishing to retain or reject the object, performs the function of being the immediate cause for the arising of ACTION CUMULATIVE OF RESULTANT (*kamma-bhava*). Such action has already been seen to be dominated by root in the case of GREED (*lobha*). What then are the qualities of the BAD ROOT OF HATRED (*dosa-akusalā-hetu*)?

ROOT OF HATRED

142. Greed, as has already been seen, operates in a manner wherein seduction, wishing, wanting and self-indulgence are important attributes⁴⁷ Its General Characteristic is "cleaving to the object ...," its inherent functional property "adhering ...," its Resultant Appearance "not letting go ..." and its Concurrent Footing "seeing enjoyment in states connected with fetters."

143. Hatred, though, is very different indeed, for whereas greed is co-operative, sympathetic and pleasant to whatsoever helps to gain its end, hatred is obstructive, antipathetic and unpleasant to whatsoever does not help gain its end. However, bearing in mind that ultimately it is IGNORANCE (*avijjā*) and CRAVING (*tanhā*) that stand behind them both, the reasons for the difference become apparent.⁴⁸ Of definitions of hatred the most extensive is that given in the second book of the Abhidhamma Piṭaka, Vibhaṅga.⁴⁹ It is given here in full as follows:

"Therein what is hatred? 'He has done me harm,' thus vexation arises; 'he is doing me harm,' thus vexation arises; 'he will do me harm,' thus vexation arises; 'he has done, he is doing, he will do harm to one dear and pleasant to me,' thus vexation arises; 'he has done, he is doing, he will do good to one not dear and not pleasant to me,' thus vexation arises; or vexation arises unreasonably. That which is similar, vexation of consciousness, resentment, repulsion, hostility, irritation, exasperation, incensement, hatred, antipathy, abhorrence, mental disorder, detestation, anger, being angry, state of being angry, hatred, being hateful, state of being hateful, disorder, being disorderly, state of being disorderly, antagonism, hostility, ferocity, abruptness, absence of delight of consciousness. This is called hatred."

144. It need hardly be said that, as in the case of greed, the intensity to which these aspects of hatred are brought to bear depends entirely upon the extent to which one is even aware that hateful states are present or even undesirable, and upon one's lack of mindfulness. Thus it is that hatred, disaffection and annoyance are the dominant conditions in thoughts that cause one to brush away a tiny greenfly from the face because the tickle has become "unbearable." Equally so this same root of hatred maintains and dominates the period of planning and organization that may precede a murder, and is that which is in control when the murder is actually committed. Hatred is present in the sharp back-answer or veiled taunt. In any aspect of ill-will, rudeness, and hostility, however slight, however powerful, there too is the root of hatred.

145. As to the four denotations of hatred, the Commentary and Visuddhimagga speak as follows:⁵⁰ The General Characteristic is of the "ferocity of a poisonous snake that has been struck." The inherent functional property is "writhing, as when poison has gone in," or "like a forest fire burning that upon which it itself depends." The Resultant Appearance is of "being

⁴⁷ See par. 69 ff.

⁴⁸ See par. 128 ff.

⁴⁹ See The Book of Analysis, par. 909.

⁵⁰ See also Exp. p. 342, Ppn, p. 532.

hateful like an enemy taking his opportunity,” and the Concurrent Footing is given as “grounds for vexation, like urine mixed with poison.⁵¹” From which it may be seen that although both greed and hatred are unskilful bad states, arising ultimately by way of CONTACT (*phassa*), FEELING (*vedanā*), CRAVING (*tanhā*), and ATTACHMENT (*upādāna*), they differ widely in structure and in the nodes of behaviour they represent.

146. As mentioned earlier in connection with greed,⁵² hatred can never operate in isolation, it always arises in conjunction with DULLNESS AND DELUSION (*moha*), i.e., IGNORANCE (*avijjā*), and has CRAVING (*tanhā*) as its background.

147. Before leaving this grouping of integral states there are two questions which may be raised. The first concerns the wording of the text itself with regard to both greed and hatred. Referring to greed⁵³ the translation of the text in its summary line says, “These eight together are known as (factorial) consciousness accompanied by greed,” thereby clearly stating that the bad root of greed is the dominating condition. In the summary line of the translation of the text for hatred, however,⁵⁴ it says only, “These two together are known as (factorial) consciousness associated with REPULSION (*paṭigha*),” seemingly making no mention of the bad root of HATRED (*dosa*). Why is there this apparent discrepancy? It can be explained in the following way.

148. In enumerating the eight greedy integral states the text says only, “Accompanied by mental pleasure (and) associated with wrong view ... Accompanied by neutral feeling (but) dissociated from wrong view, ...⁵⁵” thereby making no mention of the root of greed; consequently it was essential to make it known in the summary line by saying, “These eight together are known as (factorial) consciousness accompanied by GREED (*lobha*).”

149. The case for hateful states is somewhat different, for here the translation says, “Accompanied by mental displeasure (and) associated with REPULSION (*paṭigha*).” Here the word “repulsion” is a direct synonym for HATRED (*dosa*) when that hatred is being expressed in its active phase; this being understood it is thereby unnecessary to make separate mention of hatred in the summary line. Consequently it says, “These two together are known as (factorial) consciousness associated with REPULSION (*paṭigha*)—i.e., hatred, the BAD ROOT OF HATRED (*dosa-akusala-hetu*).

150. The second question has to do with the scope and limitation of hatred. Thus, for instance, can it be said when describing hatred as “... vexation, resentment, repulsion, irritation, antipathy,... that having these very distinct qualities it is also active in respect of particular conditions such as envy, meanness and remorse? The answer to this is most certainly yes, but by reason of the opening chapter of Abhidhammatthasaṅgaha being concerned with making clear the manner in which root conditions such as hatred, etc., are seen to act, rather than of dealing with the motives that bring roots into play, the functional details of such particular conditions are postponed until chapter 2.

⁵¹ The explanation of this phrase is as follows: Urine is disgusting, so also is poison, a mixture of both is therefore doubly disgusting and should be disposed of quickly. Hatred also is disgusting, and should likewise be quickly disposed of (Burmese Nissāya, Pyi).

⁵² See par. 75.

⁵³ See par. 58.

⁵⁴ See par. 133.

⁵⁵ See par. 68.

DULLNESS AND DELUSION

151. In considering the nature and mode of arising of bad, unskilful integral states, only those having the distinct and readily discernible qualities found among the eight rooted in greed, and the two rooted in hatred, have so far been examined. In addition to this, each has been seen to operate not just on the basis of a single root but upon a mutually co-operative twofold structure; the former being rooted in GREED and DELUSION (*lobha-moha*), the latter in HATRED and DELUSION (*dosa-moha*). The question now to be asked is whether it is possible for the arising to take place of integral states quite devoid of either greed or hatred and which are therefore merely dull and deluded. Such a condition is indeed quite possible, and it is in Verse 6 of Abhidhammatthasaṅgaha that two such integral states based only on the BAD ROOT OF DULLNESS AND DELUSION (*moha-akusala-hetu*) are shown to exist.

VERSE 6.

152. UPEKKHĀ-SAHAGATAM VICIKICCHA-SAMPAYUTTAM-EKAM
UPEKKHĀ-SAHAGATAM UDDHACCA-SAMPAYUTTAM-EKAN TI
IMANI DVE PI MOMŪHA-CITTĀNI NAMA

Meaning:

In dull, deluded integral states factorial consciousness is conjoined thus: ONE (*eka*) ACCOMPANIED BY (*sahagata*) NEUTRAL (*upekkhā*) Feeling and ASSOCIATED WITH (*sampayutta*) DOUBT (*vicikicchā*); ONE (*eka*) ACCOMPANIED BY (*sahagata*) NEUTRAL (*upekkhā*) feeling and ASSOCIATED WITH (*sampayutta*) DISTRACTION (*uddhacca*). THESE (*imāni*) TWO TOGETHER (*dve-pi*) ARE KNOWN AS (*nāma*) INTENSELY DULL AND DELUDED (*momūha*) integral CONSCIOUS STATES (*cittāni*). Thus it is that there are two such integral states wherein greed and hatred are completely absent, thereby singling out the only remaining unskilful root as the dominating factor.

153. Regarding the wording of both text and translation of Verse 6, there are two points needing some initial comment. The first is to observe that as in the case of greedy states no mention whatsoever is made in the descriptive passages as to the nature of the dominant root. In this present instance those descriptive lines include only the qualities of NEUTRAL (*upekkhā*) feeling, DOUBT (*vicikicchā*) and DISTRACTION (*uddhacca*). Consequently it is necessary, as in the case of greed, to state the nature of the root in the summary line; in this instance *momūha*.

154.⁵⁶ The second point for comment arises out of this new word *momūha*. So far, “dullness and delusion,” has been used as a joint equivalent for the Pali, term *moha*. Why then has *momūha* suddenly emerged to express the very same root? Here it is to be understood that the use of *momūha* instead of *moha* is entirely for the purpose of emphasis and intensification. In the case of greedy and hateful states it has been seen that they are invariably supported by their individual roots, but arise in conjunction with the root of dullness and delusion also, this because of its blindness and inability to penetrate to the true nature of an object. On this occasion though, where there is complete dissociation from any other roots, “dullness, and delusion” is to be seen clearly displaying its own particular qualities. In order to make this abundantly clear, and to emphasize the intensity of that DULLNESS and DELUSION (*moha*), it is augmented by the additional force of STUPEFACTION (*muyhana*). These two words *moha* and *muyhena* are then combined in accordance with the METHOD OF PHILOLOGY (*niruttinaya*) into the single word *momūha*, which is then customarily translated as “intense dullness and delusion.”

⁵⁶ See charts 3 & 6.

155. With regard to the General Characteristic and other denotations of *moha* or *momūha*, these have already been given in the discussion on greedy integral states⁵⁷ and need not be repeated here; however, it should always be appreciated that DULLNESS, DELUSION and STUPEFACTION (*moha* plus *muyhana*) are but synonyms for the true and fundamental root of IGNORANCE (*avijjā*) lit., “absence of knowledge.” What then is the purpose of using a synonym when the actual root, “ignorance,” is present all the time? Here there is a situation similar to that already mentioned as existing between HATRED (*dosa*) and REPULSION (*paṭigha*). *Dosa* is the so-called passive condition, “hatred,” of which the active phase, *paṭigha*, is “repulsion.” In a comparable way *avijjā* is the passive condition, “ignorance,” of which the active phase, *momūha* is “dullness, delusion, and stupefaction.” It is the manner in which basic ignorance proclaims itself when it becomes operative in terms of mental, verbal, and bodily action.

156. Considering this underlying and seemingly passive aspect known as IGNORANCE (*avijjā*), in what way can it be said there is ABSENCE OF KNOWLEDGE (*a-vijja*)? Here, reference is again made to Vibhaṅga where, by combining two descriptions, a very full analysis of the qualities of ignorance and dullness are obtained.⁵⁸ The following is a paraphrase mentioning only the more important elements. Thus where there is ignorance there is: absence of knowledge of SUFFERING (*dukkha*), of the CAUSE OF SUFFERING (*dukkha-samudaya*), of the CESSATION OF SUFFERING (*dukkha-nirodha*) and of the WAY LEADING TO THE CESSATION OF SUFFERING (*dukkha-nirodha-gāminī paṭipadā*); also an absence of knowledge of specific causality and dependently originated states; absence of vision and understanding, of enlightenment and penetration, of comprehension, discrimination, reflection and perspicacity; thus it is that there is stupidity, foolishness, denseness and ignorance. This is called “the element of ignorance.”

157. It is this ever present, underlying quality of ignorance, together with its derivative, “craving,” which in an ultimate sense is the pivot around and upon which the activities of existence revolve, and by which, through the agency of CRAVING (*tanhā*), they are conditioned. Ignorance is indeed the final FETTER (*saṃyojana*) which has to be broken and destroyed before a being can be said to have conquered the SUFFERING (*dukkha*) inherent in conditioned existence, and thereby to be subject no more to the self-perpetuating continuity of the causal series.

158. With regard to the four denotations of IGNORANCE (*avijjā*)⁵⁹ its General Characteristic is “absence of knowing;” its inherent functional property “stupidity;” its Resultant Appearance “concealing or hiding;” and its Concurrent Footing “the defilements.”

159. In connection with these four as the denotations of this underlying “passive” ignorance, it is both interesting and useful to make comparison with its active counterpart DULLNESS and DELUSION (*moha*).⁶⁰ In so doing it can be seen most readily how each of the denotations takes on a new but clearly derivative value as active aspects of the fundamental and fixed obstruction that ignorance presents to any progress towards understanding.

160. It has been seen in Verse 6 that the root *momūha*, apart from being accompanied by NEUTRAL FEELING (*upekkhā-vedanā*)—that is, the category of feeling which is described as NEITHER PAINFUL NOR PLEASANT (*adukkham-asukha*)—is from the very nature of its intense dullness and delusion always associated with one or other of the additional qualities, DOUBT (*vicikicchā*) and DISTRACTION (*uddhacca*). It cannot be associated with both at the same time,

⁵⁷ See par. 75.

⁵⁸ See The Book of Analysis, pars. 909 & 180; also Buddhist Psychological Ethics, pars. 1061 & 390.

⁵⁹ See also Ppn. p. 606.

⁶⁰ See par. 75.

for, as will be seen, the individual qualities of these two are not compatible with each other but only with dullness and delusion. How then can "doubt" be defined? Vibhaṅga⁶¹ says "doubt" is: "That which is puzzlement, being puzzled, state of being puzzled, perplexity, doubt, oscillation, dual path, fluctuation, uncertainty of grip, evasion, hesitation, not plunging in, rigidity of consciousness, mental scarifying."

161. As will have been observed in the definitions taken from the books of the Piṭakas, the method of expressing meaning is generally by making use of synonymous terms and phrases. However, some expansion of meaning beyond this method is often helpful, and for this one turns to the Commentaries where in this case a précis of what is said concerning "doubt" is as follows: Doubt is that which is "puzzlement." In the sense that it wavers and swings between two (views) it is called "oscillation," and inasmuch as there is this "dual path" it is obstructive to a proper course of action. Because of its inability to comprehend, there is "uncertainty of grip (on the problem)," whereby there is the indecision that is "evasion," "hesitation" and "not plunging in (i.e., not making a decision one way or another)." When doubt has arisen there is inability to decide with respect to the object; this is "rigidity of consciousness." From arising in that way, and having grasped the object, there is as it were mental scratching, therefore it is spoken of as "mental scarifying."

162. From this, DOUBT (*vicikicchā*) in conjunction with DULLNESS and DELUSION (*moha*) can be seen to be that which, while trying to seek for a solution to the attitude to take to an object, nevertheless is puzzled; it wavers, is uncertain, and is evasive. Thus "doubt" has as its General Characteristic "fluctuation;" as inherent functional property "wavering;" as Resultant Appearance "absence of certainty and being possessed of diversity;" and as Concurrent Footing "unwise attention."

DISTRACTION

163. The nature of distraction varies somewhat from doubt, for although in both instances there is difficulty in observing clearly, or arriving at a decision regarding the object of sense or mind, the basic reasons for their arising are different. When doubt is associated with dullness and delusion, it can be said that the reason for the inability to make a firm decision is due to there seeming to be such a multiplicity of ways of viewing the object or problem that it becomes virtually impossible to choose between them, and thereby be able to "plunge in" and achieve a decision. Thus, for example, if a teacher should make a perfectly correct statement concerning a certain proposition, a pupil listening might say to himself, "What if this is not the answer at all, but is just one of many other theories such as I have also heard mentioned?" Because of his basic dullness and delusion he is not able to penetrate to the truth, but is overwhelmed by his multiplicity of views. Consequently there is nothing gained and it can be said that doubt is present both with regard to the solution of the problem and in the pupil's attitude to the teacher.

164. On the other hand, the Piṭaka definition of DISTRACTION (*uddhacca*),⁶² says that it is, "Distraction of consciousness, disquietude, mental wavering and turmoil of consciousness." Of these definitions, disquietude and turmoil of consciousness are perhaps the most revealing, for they indicate that there is no mental calmness enabling the mind to consider the object clearly and consecutively. Turmoil means that the mind is whirling and tumbling about, or as the Commentary says,⁶³ "Reeling and swaying like an ox (and cart)." Under such conditions it

⁶¹ See The Book of Analysis, par. 289; also Buddhist Psychological Ethics, par. 425.

⁶² Book of Analysis, par. 291; Buddhist Psychological Ethics, par. 429.

⁶³ Exp. p. 346.

cannot then be said that decision is impossible because of a multiplicity of apparent solutions, but that because of turmoil alone it is not easy to grasp properly the single object which the mind is trying to engage. It is for this reason that the Commentary, in comparing distraction with doubt says, "Distraction wavers as to one object, doubt as to manifold objects."

165. Regarding the four denotations of distraction, Visuddhimagga says⁶⁴ the General Characteristic is "disquietude, like water whipped by the wind;" the inherent functional property "unsteadiness, like a flag or banner whipped by the wind;" Resultant Appearance being "turmoil, like ashes flung up when pelted with stones;" and the Concurrent Footing "unwise attention to mental disquiet."

166. As a further comparison between doubt and distraction it is again useful to turn to the Commentary⁶⁵ where it says,

"On being asked, 'How many kinds of consciousness roll off an object?' these two should be stated: that accompanied by DOUBT (*vicikicchā*) invariably rolls off the object, that accompanied by DISTRACTION (*uddhacca*) having from the acquirement of determination obtained a footing, then rolls off. Just as though two stones, one round and one with four sides were to roll down an incline. The round stone (doubt) would invariably roll straight down, the one with four sides (distraction) would tumble stage by stage. Thus should the example be understood."

CAUSALITY

167. With regard to the arising of dull and deluded integral states, more particularly in respect of their relationship with the causal series, that is, the ARISING OF RESULT DEPENDING ON A CAUSE (*paṭiccasamuppāda*), it should be recognized that as with the coming to be of active greed and hatred, at the BECOMING (*bhava*) stage of that series, so also do INTENSELY DULL AND DELUDED (*momūha*) integral states occur. Thus it is that despite the nature of the FEELING (*vedanā*) that follows CONTACT (*phassa*), be that feeling pleasant, painful or neutral, it is an insatiable thirst only for the pleasurable that is the CRAVING (*tanhā*) which arises because of that feeling. As has already been seen, that craving then becomes causally responsible for the coming to be of ATTACHMENT (*upādāna*) wherein a potential attitude to the object determines the type of action which is to occur in the following stage of BECOMING (*bhava*), the initial phase of which is ACTIVITY CUMULATIVE OF RESULTANT (*kamma-bhava*). It is at this initial stage that there is a dominance by either GREED (*lobha*), HATRED (*dosa*) or INTENSE DULLNESS AND DELUSION (*momūha*) governing the class of action performed in respect of the object. Therefore it can be said, because of sense contact there is activity, greedy, hateful, and deluded.

168. At this point the text of Chapter 1 of Abhidhammatthasaṅgaha makes no further enlargement regarding the structure of bad integral states, such matters being dealt with at a later stage. Consequently Verse 7 closes the section in the following manner so far as basic definitions are concerned.

VERSE 7.

169. ICCEVAM SABBATHA-PI DVĀ-DAS-AKUSALĀ-CITTĀNI SAMATTĀNI

Meaning:

⁶⁴ Ppn. p. 530.

⁶⁵ See also Exp. p. 346.

THUS in accordance with the aforesaid method (*iccevam*) and FROM EVERY ASPECT (*sabbathā-pi*) the TWELVE (*dvā-dasa*) BAD (*akusala*) integral CONSCIOUS STATES (*cittāni*) are FULLY COMPLETED (*samattani*).

The additional words are the Commentary⁶⁶ definition of *iccevam* (i.e., *iti + evam*).

170. However, in order that the material so far dealt with may be easily called to mind without having always to consider these twelve integral states in detail, there follows, as Verse 8, a short mnemonic stanza wherein each group of *akusala* states is mentioned, as also their numerical total.

VERSE 8.

171. ATTHADHĀ LOBHA-MŪLĀNI
DOSAMŪLĀNI CA DVIDHĀ
MOHAMŪLĀNI CA DVE-TI
DVĀ-DAS-ĀKUSALA SIYUM

Meaning:

EIGHTFOLD (*atthadha*) are states with ROOTS of GREED (*lobha-mulāni*) AND (*ca*) those with ROOTS of HATRED (*dosa-mulāni*) are TWOFOLD (*dvidha*): those with ROOTS of DELUSION (*moha-mulāni*) ALSO (*ca*) are TWO (*dve*); THUS (*iti*) TWELVE (*dvā-dasa*) BAD (*akusala*) integral states EXIST (*siyum = bhavanti*).⁶⁷

172. In concluding this section dealing with these twelve unskilful integral conscious states, mention should be made of a short passage in the Commentary which is most valuable from the point of view of that all important aspect of the Buddha's Teaching, practical application. It says that the act of KILLING BEINGS (*panatipata*) is two-rooted, due to the presence of both hatred and delusion: similarly that stealing or TAKING THAT WHICH IS NOT GIVEN (*adinnadana*) has two roots also, sometimes because of greed and delusion, sometimes because of hatred and delusion; likewise in the cases of FALSE SPEECH (*musavada*), SLANDEROUS SPEECH (*pisunavica*) and FRIVOLOUS SPEECH (*samphappalapa*). HARSH SPEECH (*pharusavica*) though, is two-rooted by way of hatred and delusion only.

173. It is by thus observing the arising of such conditions that it is possible to analyse one's own mental, verbal, and bodily actions in accordance with the methods of Abhidhamma, and thereby in direct accordance with the Teaching of the Buddha himself.

174. The Buddha said:⁶⁸ "Therein what is RIGHT EFFORT (*sammāvāyāma*)? Herein a Bhikkhu engenders wish, makes effort, arouses energy, exerts the mind, strives for the non-arising of evil bad states that have not (already) arisen ... (and) for the abandoning of evil bad states that have arisen ... This is called right effort."

175. That concludes the first section of Chapter 1 of Abhidhammatthasaṅgaha dealing with integral states accompanied by bad, unskilful roots.⁶⁹

⁶⁶ Abhidhammatthavibhāvitika.

⁶⁷ Paramatthadīpani, Ledi Sayādaw, p. 40.

⁶⁸ See par. 65, ref. Book of Analysis par. 4.

⁶⁹ I.e., Verses 4-8 inc.

Talk No. 4 (Part 1)

CONSCIOUSNESS, ACTION AND RESULTANT

176. When something pleasant happens one quite frequently hears a Buddhist say, "That is my good kamma;" similarly, when something unpleasant occurs, the remark is likely to be, "That is my bad kamma." To what, then, does this word "kamma" refer? Basically "kamma" means action, work, or deed; consequently where there is doing, working or acting with the mind, such as in thinking, considering or planning, it is said that MENTAL ACTION (*mano kamma*) is taking place. In a comparable way, where there is doing, working or acting with the voice, as in whispering, speaking, singing or shouting, it is said there is VERBAL or VOCAL ACTION (*vaci kamma*); likewise, in doing, working or acting by exerting the muscular and physical abilities of the body in walking, bending, lifting, pushing and so on, such movement is described as BODILY ACTION (*kāya kamma*).

177. Thus wherever there is VOLITION (*cetanā*) of some kind directed to the achievement of a purpose, be that purpose mental, vocal or physical—great or small, good or bad—it is said that at that time there is ACTION (*kamma*).

178. As has already been shown, the teachings of the Buddha constantly emphasize the principle that nothing occurs other than by way of cause. Bearing this in mind it is clear to see that when something takes place, whether it is pleasant or unpleasant, it has not come to be in a random, causeless manner, without antecedent conditions, but is invariably in causal relationship with action performed in the past. That past may be recent or it may be remote, but the causal connection nevertheless exists.

179. Conversely, when a present action is performed, be it mental, vocal or bodily, that action from the moment of its accomplishment has itself become an antecedent cause, the result of which will become apparent at some future time. That future may be proximate or it may be distant, nevertheless, whenever, wherever or in whatsoever way it does occur, the related conditions will be such as to form the natural and only possible circumstances wherein that particular resultant condition may become operative.

180. Therefore, when a person is heard to say, "That is my good kamma." it is in actuality but a shortened form of, "This pleasant or fortunate happening which is taking place at the present instant is the outcome or resultant of some good or skilful action performed by me in the past." Similarly it is so in the case of an unpleasant occurrence, but then with reference to bad or unskilful action performed in the past. Consequently in saying, "That is my good or my bad kamma." the word "kamma" is being used somewhat loosely, because strictly speaking it refers not to the present happy or unhappy occurrence itself but to the action performed on some past occasion of which the present circumstance is the RESULTANT (*vipāka*). ACTION (*kamma*) is thus the cause of RESULTANT (*vipāka*), thereby showing that action *and* resultant are causally related.

181. when at an earlier stage the Inherent Functional Property of consciousness was discussed⁷⁰ it was said that among attendant qualities, factorial consciousness is FOREMOST (*pubbaṅgama*); then, without giving a translation, it was also said that the opening words of the first verse of Dhammapada form a direct statement of that Inherent Functional Property. With these points in mind, in what other way can that verse be seen to be helpful in unravelling the

⁷⁰ See Par 98

relationship that exists between CONSCIOUSNESS (*citta*), ACTION (*kamma*), and RESULTANT (*vipāka*)?

182. A translation of the verse⁷¹ is as follows:

"Consciousness is foremost among mental states,
Consciousness is their chief, consciousness is their origin.
If with corrupt consciousness one speaks or one acts;
On account of that, suffering follows one
Just as the wheel (follows) the hoof of the draught (ox)."

183. What is to be learned from these lines? First of all, as the Buddha's own word, this verse makes the direct statement that among concomitant mental states consciousness is the most important in that it is foremost, is their leader and that those qualities come to be only because of the arising of consciousness. Secondly, in saying, "If with corrupt consciousness one speaks or one acts," the Buddha makes doubly clear that not only is consciousness foremost so far as concomitant states are concerned, but in being so has precedence over, controls and dominates the actions of speech and bodily movement as well. Thirdly, in saying, "On account of that (corrupt consciousness) suffering follows one," the Buddha points out that because of mental, vocal and bodily action that has arisen based on corrupt integral states, resultants are produced which follow one and become apparent in the form of suffering, displeasure and dissatisfaction. Then fourthly, by saying, "Just as the wheel (follows) the hoof of the draught (ox)" that draws a cart behind it, the Buddha shows the burden and proximity of the suffering that is omnipresent where unskillful action occurs within a causal series such as he has shown to exist.

184. In the companion verse to that just given—verses 1 & 2 of Dhammapada form a PAIR (*yameka*)—the Buddha says:

"... If with clear consciousness⁷² one speaks or one acts;
On account of that, pleasantness follows one
Just as inseparably as a shadow."

Thus, in speaking of good states as well as bad, the Buddha shows that in the same way as unskillful BAD ACTION (*akusala kamma*) produces unpleasant BAD RESULTANT (*akusala vipāka*) so GOOD ACTION (*kusala kamma*) produces pleasant GOOD RESULTANT (*kusala vipāka*).

185. Three small points need to be spoken of before going on to explain more fully some of the many ways in which resultant states become manifest. The first of these is that it should not be thought that pleasant or unpleasant conditions arise only by way of being resultants of good and bad action, this is by no means the case. The second point is that it cannot be said that conditions invariably occur whereby resultant states can become effective. This is an important consideration, for it is clear that if such conditions did apply there could be no end to the arising of resultant states, and, as a consequence of that, no release from the cycle of causality with its ever present burden of SUFFERING (*dukkha*). At this stage, though, Abhidhammatthasaṅgaha does not deal with the other causes because they are not directly associated with ACTION (*kamma*). The third point is the small but necessary one of differentiating between two words. Where *kamma* is spoken of, meaning action, it is spelt KAMMA; nevertheless, when spoken, its sound can easily be confused with *kāma* spelt KAMA, and meaning sense pleasure. Certainly as the result of SENSE PLEASURE (*kāma*), ACTION (*kamma*) can take place, but the words themselves are quite different and not to be confused with one another.

⁷¹ Dh., Yamakavagga 1.

⁷² Comy, i.e., virtuous and without covetousness.

186. It has already been shown that of the twelve BAD integral CONSCIOUS STATES (*dvayatā akusala cittāni*) eight are rooted in greed, two in hatred and two in intense delusion. Clearly all these are bad and unskillful, and find expression not only in MENTAL ACTION (*mano kamma*) but, because of what has been said of consciousness in the first verse of Dhammapada. in VOCAL ACTION (*vaci kamma*) and BODILY ACTION (*kāya kamma*) also; from which it is essential to recognize that not a single intentional sound or movement can come from an individual without its being initiated, dominated and controlled by consciousness.

187. Since these twelve bad integral states become operative in the three modes of ACTION (*kamma*), mental, vocal and bodily, it is clear that a very considerable mass of BAD RESULTANT (*akusala vipāka*) is continually being heaped up to become manifest when just the appropriate conditions present themselves. Given such conditions, in what manner do they present themselves? In the verse of Dhammapada quoted, saying, "Suffering follows one just as the wheel (follows) the hoof of the draught (ox)," the Buddha was speaking in a general sense and therefore without technical detail. His method of Abhidhamma teaching, though, delves much more deeply, and is far more explicit, for it reveals what is not immediately evident although implied by those words, "Suffering follows one ..."

188. In this connection consider for the moment two things, a visible object such as a flower and the origin of sight, the eye. When with the eye one looks at a flower, the conventional assumption is that at the instant visual contact is achieved between the eye and the flower one experiences simultaneous full awareness of that visible object. The commonly accepted definition of full awareness is of a complex condition comprising knowledge and recognition of the object, coupled with whatever feeling is associated with it—pleasant, painful, or neutral—together with one's volitional attitude as to whether to retain or repel the object.

189. The attitude of Abhidhamma analysis to this subject is very different indeed, for it maintains that the moments of FULL AWARENESS (*javana*) of the object come only as later stages in a whole series of extremely rapid thought moments. Each of these earlier thought moments, though, is considered as performing a particular and definite function in building up, by way of causally related but simply structured integral states, to a point where by the individual activity of those states the original bare sense stimulus has been investigated and determined. Then, and only then, does there occur awareness of the object as a fully developed and conceptualized thought picture accompanied by identifiable feeling and volitional attitude.

190. Still bearing in mind the Buddha's words on suffering following one, what are these causally related but simply structured integral states? In order that they may be defined, and the nature of their participation shown in the relationship between CONSCIOUSNESS (*citta*), ACTION (*kamma*), and RESULTANT (*vipāka*), something more must be said of consciousness.

191. In order to differentiate between the two values accorded to CONSCIOUSNESS (*citta*), firstly in its basic sense of pure awareness, and secondly in the use of that same word "consciousness" to mean a complex of factorial CONSCIOUSNESS and MENTAL CONCOMITANTS (*citta-cetasikā*), the terms "factorial consciousness" and "integral consciousness" respectively were adopted earlier on. Now, however, some further interpretation and elucidation needs to be made, more particularly with regard to the second term "integral consciousness;" the reason for this being what has just been said concerning the difference between one's usual assumptions as to the way in which full awareness of an object occurs, compared with the more involved process leading up to and including that full awareness as detailed in Abhidhamma.

192. First of all it must be emphasized that the nature of factorial consciousness remains quite unchanged, no matter under what circumstances it arises, exists, and passes away. As has already been said, *citta* in that sense means just awareness of the object, nothing more, nothing less, and in that capacity, as always, it stands as a fundamental and essential building brick or AGGREGATE (*khandhā*) of sentient existence. On the other hand, when considering integral consciousness, it needs to be appreciated that the factorial consciousness embodied in that integral state—a prerequisite though it is—is but a single factor among many factors. Every one of these, although “joined inseparably with consciousness,⁷³” arising with it, existing with it and passing away with it, possesses nevertheless its own inherent qualities which, operating in association with each other as well as with and being led by factorial consciousness, form discrete complexes; these complexes acting as units, capable individually of performing certain clearly defined functions and nothing other than those.

193. As a simile it could be said that depending upon the form into which a piece of clay is moulded, it can perform certain functions. These functions may not necessarily be directly related to each other, even so, they are at the same time based upon the clay which is intrinsic to all of them. For example, bricks, chimney pots, cups, floor tiles, statues, and kitchen sinks may be made of clay, existing because of clay and unable to perform their particular functions other than by virtue of the presence of clay. Nevertheless, in each of the objects mentioned it is the other qualities, or factors, of shape, size, colour, etc., which give the appearance of being dominant features and of determining the use of the object; the clay being almost forgotten. They are, in a sense, the “factors” which, together with the clay, determine the nature of the final object.

194. In a comparable way is it so with integral consciousness. Depending on the mental concomitants associated with factorial consciousness, so the functions which an individual complex or compound state, i.e., a *citta-cetasika-dhamma* is able to perform is rigidly determined by the possibilities and limitations imposed upon it by its mental concomitants. However, in this case factorial consciousness is indeed recognized as being “foremost, the chief, the originator;” its presence is accepted in the sense of its being the basis, and in much the same way as when we say, “Clay pot, clay sink, clay tile, clay statue” and so on, clay is recognized as being the true basis, so consciousness is recognized as being the basis of each discrete complex.

195. So it is when “seeing” a flower; that is on an occasion when a complete COURSE OF CONSCIOUS PROCESS (*citta-vīthi*) takes place. Because of factorial consciousness being intrinsic to the many very different but causally related functions which occur serially from the instant of contact through to the function which we would ordinarily call “seeing” or “full awareness” each of those individual functions is said to be an integral conscious state. It is in this way that many integral states which we might more ordinarily refer to as mental processes, and as being quite distinct, different and separate from “full awareness” or “consciousness,” are in Abhidhamma included under this general term CONSCIOUSNESS (*citta*). It is such states, together with “full awareness,” which, for want of a broader and more revealing term, are here called integral states, integral consciousness, or integral conscious states.

196. For the purpose of making clearer how all these states are grouped it would be useful to summarize a little. Stated very simply, and without technical detail, it can be said that in the complete process of experiencing an object by way of the appropriate sense door there are two distinct phases. In the first phase comes the arising of a series of causally related but simply structured integral conscious states performing a number of individual and progressively

⁷³ See Exp., p. 65.

associated functions. These integral states do not rise to the level of full awareness, so one cannot be said to be “conscious” of their operation. These are succeeded by a second phase wherein, serially connected to the first phase, there arises a yet further series of causally related, but much less simply structured integral states, in which full awareness of the object is apparent together with a volitional attitude to it, and an appropriate class of feeling. All the integral states comprising these two phases are fully active so far as their individual functions are concerned, but those of the second phase are active to a much more powerful degree than those of the first. However, the most important feature to observe is the reason for this difference of intensity.

197. It has already been said that the Buddha emphasized that nothing occurs other than by way of cause. This second phase of the conscious process, being volitional and powerfully active, demonstrates one aspect of this very relationship, for here is CONSCIOUSNESS (*citta*) being operative in any of the three fields, mental, vocal or bodily. Because of this, such integral states are said to be productive of action; thus CONSCIOUSNESS (*citta*) is the cause of ACTION (*kamma*). If there is action, then, as has already been shown, there must be some outcome to that action. But what type of outcome? When people say, “This is my good kamma,” “This is my bad kamma,” they speak lightly and unspecifically. When the Buddha spoke analytically of such matters he was quite specific. Thus, among the RESULTANT (*vipāka*) states that can arise as the outcome of action, the Buddha made it quite plain as stated in Dhammasaṅgaṇī⁷⁴ that the integral states performing the several functions of the first phase of the conscious process are, with the exception of two, entirely the RESULTANTS (*vipāka*) of GOOD AND BAD ACTION (*kusala-akusala-kamma*) heaped up in the immediate or remote past.

198. Returning now to these two phases of the conscious process it is apparent that the first is less obvious and less assertive than the second, and that its individual integral states are themselves the RESULTANTS (*vipāka*) of past ACTION (*kamma*). In contrast to this, the integral states of the second phase are strongly active and are the actual producers of resultants. How, then, in classification can these states be known apart?

199. Considering first the states which belong to the second phase, even though only those described as BAD integral CONSCIOUS STATES (*akusala cittāni*) have so far been dealt with. These twelve, i.e., eight greedy, two hateful and two intensely dull, have been shown as coming into operation by reason of the bad roots of GREED (*lobha*), HATRED (*dosa*) and DELUSION (*moha*), all being backed by IGNORANCE (*avijjā*) and CRAVING (*tanhā*). However, every one of the twelve is an excellent example of an integral state which is active in the sense of being fully aware of the object instrumental to its arising, is active in the sense of being operative mentally, vocally or bodily, and is therefore active in the sense of being productive of RESULTANT (*vipāka*). So, together with other active resultant producing integral states, to be examined later, such phase two integral states can be classed as being productive of resultant. When, therefore, it is especially necessary to emphasize that there is inherent in certain classes of integral states this capacity for ACTION (*kamma*), and thereby a potentiality for the production of RESULTANT (*vipāka*), i.e., of being STATES PRODUCTIVE OF RESULTANT (*vipāka-dhamma-dhamma*),⁷⁵ they will be referred to as (productive) integral states.

200. It has been seen that among bad (productive) integral states the bad roots are the basis of their action. Such roots have a very strong hold, and dominate the activity of beings to an alarming degree. Despite this, though, from the point of view of Abhidhamma analysis, bad unskillful states are considered as being weak. The reason for this lies in the very little striving

⁷⁴ B.P.E. e.g., par. 556.

⁷⁵ See par. 57, Dhs. text of Tika No. 3.

needed to cause their arising, they occur easily and effortlessly. Coupled with this they have throughout their practice the effect of falling easily to lower and deeper degrees of unskillfulness, and, what is more, have no tendency whatsoever to rise to progressive levels. Therefore, on account of this general easiness and lack of need for effort and exertion in their accomplishment, they are considered as being states both weak and harmful.

201. Since, as might be expected, the power and far reaching effect of RESULTANT (*vipāka*) depends very much upon the power and effort associated with the ACTION (*kamma*) producing it, it is clear that relatively effortless bad states give rise to similarly weak resultants. Thus, in the case of these particular twelve bad (productive) integral states, the resultants produced cannot be regarded as being strong; in spite of this, though, they are capable of performing a variety of the functions essential to the first phase of the conscious process. How, then, should such resultant states be classified?

202. Earlier, in the nature of a simile, something was said of plants with their roots, flowers, and fruit.⁷⁶ That simile can now be carried further. If a plant be strong and possessed of good roots, it will bear both flowers and fruit: if it has bad roots it will be a sickly thing which may indeed bring forth flowers but no fruits. Now fruit, having the potentiality for being the producer of further roots, looks forward to a future of more and stronger plants; on the other hand, flowers alone, although performing certain necessary and useful functions, possess no such potentiality for the making of roots, and in this sense can indeed be said to be without roots. Similarly may it be said of unskillful (productive) integral states, they are sickly plants with bad roots, and, by reason of that, slide into further decadence. They do not, as do good states, give rise to both flowers and fruit with their promise of future strength and progress; bad states give rise, as it were, only to flowers, that is, to resultant states which perform certain necessary functions but which have no innate potentiality to future progress. Although originating from states with roots, they are themselves devoid of roots. Consequently such resultant states as perform particular functions in the first phase of the conscious process are known as ROOTLESS integral CONSCIOUS STATES (*ahetuka-cittāni*). It is such integral states, the rootless resultants of previous bad action that Abhidhammatthasaṅgaha enumerates in verse nine.

VERSE 9

203.⁷⁷ UPEKKHĀ-SAHAGATAM CAKKHU-VIÑÑĀNAM
TATHĀ SOTA-VIÑÑĀNAM
GHĀNA-VIÑÑĀNAM
JIVHĀ-VIÑÑĀNAM
DUKKHA-SAHAGATAM KAYA-VIÑÑĀNAM
UPEKKHĀ-SAHAGATAM SAMPATICCHANA-CITTAM
UPEKKHĀ-SAHAGATAM SANTIRANA-CITTAN-CE-TI
IMĀNI SATTA-PI AKUSALA-VIPĀKA-CITTĀNI NĀMA

Meaning:

There is EYE-CONSCIOUSNESS (*cakkhu-viññāna*) ACCOMPANIED BY (*sahagata*) NEUTRAL (*upekkhā*) feeling; SO ALSO (*tathā*) EAR-CONSCIOUSNESS (*sota-viññāna*), NOSE-CONSCIOUSNESS (*ghana-viññāna*) and TONGUE-CONSCIOUSNESS (*jivhā viññāna*); there is BODY-CONSCIOUSNESS (*kāya-viññāna*) ACCOMPANIED BY (*sahagata*) bodily PAIN (*dukkha*),

⁷⁶ See par. 64.

⁷⁷ See chart 7.

RECEIVING-CONSCIOUSNESS (*sampāṭicchana-citta*) ACCOMPANIED BY (*sahagata*) NEUTRAL (*upekkhā*) feeling, AND (*cā*) INVESTIGATING-CONSCIOUSNESS (*santīraṇa-citta*) ACCOMPANIED BY (*sahagata*) NEUTRAL (*upekkhā*) feeling, THESE (*imāni*) SEVEN TOGETHER (*satta-pi*) ARE KNOWN AS (*nāma*) integral CONSCIOUS STATES (*cittāni*) which are the RESULTANT (*vipāka*) of BAD (*akusala*) action.

204. Thus it is, that where concerning previous unskillful action, verse 1 of Dhammapada says, "... suffering follows one ...," it was to these seven, and to certain other functions also performed by bad resultant integral states, that the Buddha referred.

ABHIDHAMMATTHASAṄGAHA Talk No. 4 (Part 2)

205. In verse 9 it has been seen that as the outcome of the activity of the twelve bad (productive) integral states, there can arise seven bad resultant states which are rootless. There are, however, two other groups of rootless states which are not bad and which arise from quite other causes.

206. The first of these is a collection of eight rootless resultant integral states, which although closely comparable with those just given are nevertheless the outcome of GOOD (productive) ACTION (*kusala-kamma*). In this connection it will be remembered that in the second of the twin opening verses of Dhammapada, the Buddha when speaking of good action said, "Pleasantness follows one just as inseparably as a shadow.

As has been explained, that which follows one is the RESULTANT OF ACTION (*kamma-vipāka*), and although, as will be seen later, the nature and outcome of good (productive) integral states is widely different from that of bad states, there nevertheless exists this group of eight GOOD-RESULTANT-ROOTLESS-integral-CONSCIOUS STATES (*kusala-vipāk-āhetuka-cittāni*) which are in many ways structurally indistinguishable from the bad resultants already given, and which perform similar functions but have as their origin the weaker and less dominant aspects of GOOD ACTION (*kusala-kamma*). Which are the eight rootless resultant states?

VERSE 10

207.⁷⁸ UPEKKHĀ-SAHAGATAM KUSALA-VIPĀKAM CAKKHU-VINNANAM
TATHĀ SOTA-VIÑÑĀNAM
GHĀNA-VIÑÑĀNAM
JIVHĀ-VIÑÑĀNAM
SUKHA-SAHAGATAM KĀYA-VIÑÑĀNAM
UPEKKHĀ-SAHAGATAM SAMPATICCHANA-CITTAM
SOMANASSA-SAHAGATAM SANTIRANA-CITTAM
UPEKKHĀ-SAHAGATAM SANTIRANA-CITTAN-CE-TI
IMĀNI ATTHA-PI KUSALA-VIPAK-ĀHETUKA-CITTĀNI NĀMA

Meaning:

There is EYE-CONSCIOUSNESS (*cakkhu-viññāna*) that is the RESULTANT (*vipāka*) of GOOD (*kusala*) action and which is ACCOMPANIED BY (*sahagata*) NEUTRAL (*upekkhā*) feeling; SO ALSO (*tathā*) EAR-CONSCIOUSNESS (*sota-viññāna*), NOSE-CONSCIOUSNESS (*ghāna-viññāna*) and TONGUE-CONSCIOUSNESS (*jivhā-viññāna*); there is BODY-CONSCIOUSNESS (*kāya-viññāna*) ACCOMPANIED BY (*sahagata*) bodily PLEASURE (*sukha*), RECEIVING-CONSCIOUSNESS (*sampaticchana-citta*) ACCOMPANIED BY (*sahagata*) NEUTRAL (*upekkhā*) feeling, INVESTIGATING-CONSCIOUSNESS (*santirana-citta*) ACCOMPANIED BY (*sahagata*) MENTAL PLEASURE (*somanassa*) AND (*ca*) INVESTIGATING-CONSCIOUSNESS (*santirana*) ACCOMPANIED BY (*sahagata*) NEUTRAL (*upekkhā*) feeling.

THESE (*imāni*) EIGHT TOGETHER (*attha-pi*) ARE KNOWN AS (*nāma*) ROOTLESS (*āhetuka*) integral CONSCIOUS STATES (*cittāni*) which are the RESULTANT (*vipāka*) of GOOD (*kusala*) action.

⁷⁸ See chart 7.

208. Thus in verses 9 and 10 are listed seven bad resultants and eight good resultants respectively, each of which is rootless and performs a function in the first phase of the conscious process. What are these functions, and in what way are they performed?

209. Initially, and in both cases, come the five physical senses, i.e., the functions of seeing, hearing, smelling, tasting, and touching. These five are followed by two further functions, those of receiving and investigating, making, because of one special variant in feeling, totals of seven and eight separate functions respectively, each being performed by a rootless integral state arising, as is appropriate, as the resultant of past bad or past good action.

210. In describing the natures of these individual functions it is necessary to stop and think a little of what occurs during the complex process of, for example, seeing an object with the eye. At this juncture it is not intended to inquire deeply into the entire course of the conscious process, the reason for this being that chapter four of *Abhidhammatthasaṅgaha* is devoted entirely to a detailed study of this important subject, and in order that it may be properly understood it must of necessity be seen against a background of knowledge of the three preceding chapters. Nevertheless, a small amount of preliminary explanation is helpful if only to explain the relevance of these rootless states within the framework of *Abhidhamma* analysis.

211. Here it is necessary to remind oneself of what has been said previously,⁷⁹ for whereas we ordinarily assume that we have only to turn our eyes upon an object for there to arise simultaneous full awareness of that object, *Abhidhamma* speaks of a serial process with many functions and as having rootless and productive phases. These are two very different views, but examination soon convinces one that the first is a very considerable over-simplification, and that there must indeed be some intermediate stages between initial sense contact with a purely physical stimulus and the expression of that stimulus as a fully conceptualized object of consciousness.

212. If, as has been said, the whole series of individual integral states occur between the moment of contact and full awareness of the object, what exactly is meant when individual reference is made to any one of the five senses, each of which, considered individually, represents only one stage in a conscious process? According to *Abhidhamma* each of the five senses is looked upon as performing a far simpler and less complex function than might ordinarily be supposed. Nevertheless, simple though it may be, some understanding of it as a function is most important, particularly as it gives a clue to the way in which we build up that mental world upon which we so largely base our trust and wherein we perpetually build up and reinforce the idea of "I," "me," and "mine," together with all that is associated with such concepts.

213. Basically, when reference is made for example to the function of seeing, one is considering a rootless resultant integral state called EYE-CONSCIOUSNESS (*cakkhu-viññāna*), meaning thereby the arising of consciousness with regard to a visible object. That is the mental side of the matter. Equally important, though, are the physical considerations involved, because the object in connection with which consciousness has arisen is physical, i.e., it is material; the organ of sight, the eye, is purely material as also are the optical and muscular processes associated with it in the course of "looking at" the object. Yet in connection with this material object and material sense organ one speaks of the arising of consciousness; something which is not considered as being material in any way. What is meant by this sudden change in terms? Here the whole question needs to be examined in a series of simple stages.

⁷⁹ See par. 188/9.

214. First of all there is the object being viewed, which, to be able to see anything at all, presupposes the presence of light. Secondly, it has to be appreciated that although the object itself may be spoken of broadly as being material, it must nevertheless be possessed of certain qualities intrinsic to it, which, in the presence of light, render it visible; thus shape and colour are essential. In other words the object must possess an innate quality of visibility in order that it may be seen. Thus a gas may well be invisible and detectable only by another sense, e.g., the sense of smell; however, assuming that there is a visible object and that light is present, what additional factors are essential for there to be awareness of that object? Clearly there must be the physical organ called the eye, for there is no seeing of visible objects other than by way of the eye. That eye being present, it must, in the purely physiological sense, be complete, with its optical properties correct in matters of clarity and focus. Moreover, it must be directed so that the visible qualities impinge upon its optical structure in such a way that the visible image of the object falls on what one may regard as the sensitive surface of the eye. This sensitive surface of the eye is the whole core to the process of seeing, for it is at this point, in a living being alone, that there exists what may be regarded as an interface between the physical world and the mental world.

215. This sensitive surface upon which the visual image of the object may be said to impinge is that which in Abhidhamma terminology is known as SUBTLE MATERIAL QUALITY (*pasāda-rūpa*)⁸⁰ In using the term “subtle material quality,” the meaning implied is of its being entirely MATERIAL (*rūpa*), yet possessing a uniquely delicate sensitivity capable of acting as a support, basis or point of origin for the arising of the utterly non-material MENTAL QUALITY (*nāma*), integral consciousness. Thus when the purely physical stimulus of the visible object being viewed impinges upon this sensitive surface of subtle material quality, there arises, simultaneously with that impingement, a simple uncomplicated form of integral consciousness reproducing in mental terms the exact details of the impinging physical data. This sensitive surface, this basis of support for the arising of consciousness and its associated concomitants, this interface between purely material qualities and purely mental qualities is thus the point at which the ultimate, utterly impersonal impinging physical stimuli are restated, not now in physical terms but as equally ultimate, utterly impersonal integral conscious states.

216. So it is that in the same way as those purely physical stimuli, arising by virtue of the presence of the object and light, are possessed of no such idea as “I am a pleasant view of flowers and trees,” or “I am an unpleasant view of misery and squalor,” so also the simple rootless resultant integral conscious states, which in arising restate and duplicate as it were in mental terms those physical stimuli, are equally devoid of any attitude towards the object. They perform only the bare function of seeing.

217. What then are the four denotations of consciousness when performing this bare function of seeing? Of this the Commentary Atthasālini⁸¹ says, “The General Characteristic is eye-based awareness of the visible. The inherent functional property is that of having visible characteristic as object. The Resultant Appearance being a condition (or state) of facing the visible object, and the Concurrent Footing the disappearance of ‘inoperative-mental-element’ with regard to the visible object”. From this it should be understood that when EYE-CONSCIOUSNESS (*cakkhuvīññāna*) is referred to in connection with the function of seeing, what is meant is nothing more than the bare fact of being aware of the object in terms of its shape and colour.

⁸⁰ i.e., the rootless integral state yet to be described, called “pañcadvārāvajjana.”

⁸¹ See also Exp., p. 348.

218. It will already have been observed from the wording of verses 9 and 10, that as regards FEELING (*vedanā*) this is NEUTRAL (*upekkhā*) in both cases. Consequently eye-consciousness, being nothing but awareness of the visual stimulus impinging upon the sensitive surface, is not accompanied by any such attitude as, "This is unpleasant, this is pleasant," but is accompanied on every occasion by utter neutrality of feeling. It is for this reason that both verses 9 and 10 state, "There is EYE-CONSCIOUSNESS (*cakkhu-viññāna*) ACCOMPANIED BY (*sahagata*) NEUTRAL (*upekkhā*) feeling," thereby stating no class of feeling alternative to neutrality.

219. If eye-consciousness operates in this simple neutral fashion, what can be said of the other four senses? Apart from the obvious differences in the nature of the sense stimuli themselves, there is but little difference in their modes of function. So far as the ear is concerned, its particular and unique sensitive surface of subtle material quality stands as the interface between the stimulus called sound and the arising of conscious data representative of that stimulus. Thus, in the same simple and neutral way as eye-consciousness arises performing its bare function of seeing, so also arises the rootless bad or good resultant integral state of EAR-CONSCIOUSNESS (*sota-viññāna*) performing its bare function of hearing, and accompanied therewith by absolute neutrality of feeling.

220. Similarly with consciousness of odours, i.e., NOSE-CONSCIOUSNESS (*ghana-viññāna*), and consciousness of savours, i.e., TONGUE-CONSCIOUSNESS (*jivhā viññāna*). Each has its specifically located sensitive surface of unique subtle material quality; the first responding only to the stimulus of odour, and enabling consciousness to arise in accord with that stimulus alone; the second responding solely to the stimulus of flavour, and thereby to the arising of consciousness of flavour. As with eye-consciousness and ear-consciousness, so also does neutral feeling arise with both these latter integral states as they perform their bare functions of smelling and tasting respectively.

221. Consciousness of physical contact, i.e., TOUCH-CONSCIOUSNESS (*kāya-viññāna*) differs in certain ways from the other four senses. This is particularly so in as much as the so-called sensitive surface constitutes, to a greater or lesser degree, the whole bodily area. In the ordinary way it is not considered unusual that every part of the body is capable of causing awareness to arise when pressure is occasioned by some external or internal source. Nevertheless, from the very fact that awareness does indeed arise, evidence thereby exists that the surfaces of the body are themselves associated with some such subtle material quality as are the other senses, but in this case one where only when direct physical contact is made with it does the arising of the conscious condition take place. Here, therefore, it can be appreciated that, as with the other senses, it is contact by an appropriate stimulus that causes consciousness to arise. In this instance, though, there is a difference between touch-consciousness and the others.

222. In the case of sight the visible object itself is always distant and apart from the actual sensitive surface, be that distance 25 cm or 25 km. Contact with the object itself does not therefore take place in the same direct manner as is the case with touch, but only by way of the impingence of visible quality. So also in the case of sound; direct contact is not made with the actual mechanical disturbance productive of sound, be it a bee's wing or a pile driver, but only with the audible feature associated with the source as transmitted by the intervening air to the sensitive surface of the ear. Contact is to be regarded as subtle rather than direct. In a similar way with both odours and savours, contact between the appropriate sensitive surface and sense object is not comparable with a hammer hitting an anvil, but of a delicate derivative quality making delicate impingement upon the subtle material quality of the sense organ.

223. The Commentary Atthasālini,⁸² actually uses this simile of the hammer and anvil, saying that in the case of the first four senses it is like four anvils on which are pieced four masses of cotton, which in turn are hit, not by hammers but by further masses of cotton, that is a mere touch. In contrast to this is the case of physical contact giving rise to touch consciousness, that is, where the material object actually makes direct contact with the body surface. Even here the Commentary still compares the sensitive surface with an anvil having a mass of cotton on it, but this time struck with a hammer which breaks through the cotton and physically strikes the anvil. It is here, because of this direct striking, that the greatest difference is apparent between the first four senses and touch. In the case of the first four, because contact is delicate and derivative in nature, the feeling associated with the arisen integral consciousness is invariably neutral. In the case of touch, though, because the very quality of its impact relative to the other senses is not delicate, is not derivative, but is direct and powerful, the nature of the feeling associated with the risen consciousness can never be neutral but is always either painful or pleasant.

224. This difference in class of feeling is clearly shown in the wording of verses 9 and 10. There, if for reasons of the nature—nimitta—of the object itself the function of touching is performed by a rootless resultant of previous BAD ACTION (*akusala-kamma*), verse 9 says, "There is BODY-CONSCIOUSNESS (*kāya-viññāna*) ACCOMPANIED BY (*sahagata*) bodily PAIN (*dukkha*).“ Alternatively, if for reasons of the nature of the object itself the function of touching is performed by a rootless resultant of previous GOOD ACTION (*kusala-kamma*), verse 10 shows this difference by saying, "There is BODY-CONSCIOUSNESS (*kāya-viññāna*) ACCOMPANIED BY (*sahagata*) bodily PLEASURE (*sukha*).“

225. From verses 9 and 10, and from what has so far been said of the arising of sense consciousness, it can be recognized that when analysed in accordance with Abhidhamma the five individual functions of seeing, and so on, can each be shown as being performed by either one of two distinct classes of resultant integral states. These states are, in verse 9, the rootless resultants of past bad action, and in verse 10 the rootless resultants of past good action. Because of this twofold mode of arising it is usual in Abhidhamma terminology to refer to these integral states not just as FIVEFOLD-SENSE-CONSCIOUSNESS (*pañca-viññāna*), but as TWICE-FIVEFOLD-SENSE-CONSCIOUSNESS (*dvi-pañca-viññāna*), thereby calling to mind not only their basic five fields of sensitivity but also their twofold sources of origin. Thus when the term "twice-fivefold-sense-consciousness" is used without any further qualification, nothing other than consciousness by way of the five physical senses is intended.

226. It will have been noticed in verses 9 and 10, that in respect of the five senses the Pāli term "viññāna" has been used as an equivalent for "consciousness" or "awareness" instead of the more familiar form "citta." This is nothing more than conventional usage, for so far as meaning is concerned the two words are virtually interchangeable. This is adequately shown in both Dhammasaṅgani and Vibhaṅga⁸³ where they represent but two of a whole series of equivalents. In translation, alternative forms are frequently accorded to them for convenience or variety of wording, but as is well shown in the Assutevasutta of Nidāna Saṃyutta the three terms "citta" "mano" and "viññāna" have the same meaning.⁸⁴ Conventionally, in Abhidhamma studies, "viññāna" is used when referring to twice-fivefold-sense-consciousness. It is also employed in connection with the AGGREGATE OF CONSCIOUSNESS (*viññāna khandhā*), mentioned earlier as one of the five fundamental building bricks of sentient existence. Later it will be seen that

⁸² See Exp., p. 349/50.

⁸³ See B.P.E, par. 6, and B.O.A., par. 249.

⁸⁴ Thus "... cittaṃ iti'pi mano iti'pi viññānaṃ iti'pi." See also G.S., Vol. 2, p. 65.

“viññāna” is sometimes even suffixed to “mano” to more clearly identify certain groupings of integral states.

227. Having described the way in which the various individual classes of sense stimuli impinge upon specific sensitive surfaces, with a consequent arising of rootless resultant integral conscious states, it is interesting to consider what might logically be expected to follow. Initially it can be appreciated that by virtue of the unique properties inherent in the five areas of SUBTLE MATERIAL QUALITY (*pasāda-rūpa*), five utterly different stimuli result in one thing only. What one thing? Awareness of the stimulus. However, in order that such bare conscious data may be directed into a more comprehensive thought process, it would seem there should be some point of collection for this very varied data prior to its being examined, in order that its characteristics may become apparent. According to Abhidhamma this is precisely what does occur, for immediately following the operation of any one of the five doors of sense there arises quite automatically and as part of a fixed sequence—a rootless resultant integral state, accompanied by neutral feeling, performing the function of RECEIVING (*sampaṭicchana*). This function acts purely as a focus or collecting point for the five classes of sense consciousness. Where because of the nature of the object the appropriate sense consciousness has been performed either by a good rootless resultant, or by one that is bad, so this RECEIVING CONSCIOUSNESS (*sampaṭicchana-citta*) is performed by a corresponding good or bad rootless resultant. It is a simple integral state arising only at the appropriate instant, and having just this one function of passively collecting. As to its four denotations the Commentary⁸⁵ says it has the General Characteristic of awareness of the visible, and so on, immediately following upon eye-consciousness, etc.; the inherent functional property of receiving visible quality, and so on; the Resultant Appearance of that same condition (i.e., of receptiveness), and the Concurrent Footing of the disappearance of eye-consciousness, etc.

228. The function performed by consciousness at the stage that arises immediately upon the cessation of RECEIVING (*sampaṭicchana*) is of considerable importance, because it is here that the individual stimuli are examined for the first time. Up to and including the function of receiving; visible stimuli, audible stimuli and so on can be looked upon as being just bare sense data. Dependent upon its origins this data does however reveal characteristic forms or patterns, and it is at this new stage following receiving that these are examined by rootless resultant integral consciousness performing the function of INVESTIGATING (*santīraṇa*). Here, integral consciousness is aware of the characteristic marks, signs or patterns implicit in the bare sense data, thereby providing the basis upon which that same data becomes fully conceptualized and, in consequence of that, recognizable as an object in the conventional sense.

229. As with preceding functions, so, depending upon the nature of the object, investigation is likewise performed either by a good or by a bad rootless resultant integral state accompanied by neutral feeling. If, however, the feature of very great desirability is implicit in the nature of the bare sense data, then, at the investigating stage only, that function is performed by a GOOD ROOTLESS RESULTANT CONSCIOUS STATE ACCOMPANIED BY PLEASANT MENTAL FEELING (*somanassa sahaḡata ahetuka kusala vipāka citta*). It is this additional aspect of investigating consciousness that accounts for there being eight rootless resultants in verse 10, whereas in verse 9 only seven bad resultants occur.

230. Regarding investigating consciousness itself the Commentary says⁸⁶ its General Characteristic is awareness of the six objects (i.e., the five physical sense objects, and when

⁸⁵ See also Exp. p. 350.

⁸⁶ See also Exp. p. 351.

performing a different function later in the conscious process, mental objects also). Its inherent functional property is investigating, etc., (etc. referring to certain other functions it performs); its Resultant Appearance that same condition (i.e., investigating, etc.), and its Concurrent Footing the heart basis.

ABHIDHAMMATTHASAṄGAHA Talk No 5 (Part 1)

231. The two groups of integral conscious states enumerated in verses 9 and 10 are distinguished from all others, not only by being ROOTLESS (*ahetuka*) but by being the RESULTANTS (*vipāka*) of either past unskillful or past skillful action. Thus they constitute as a whole a special category of conscious states known as ROOTLESS RESULTANTS (*ahetuka-vipāka*). However, as will become apparent, the fact that an integral state is the resultant of past action does not necessarily determine that it must also be rootless: conversely, if a state is classified as rootless it does not mean that of necessity it must at the same time be the resultant of past action.

232. Here there might well appear to be something of a dilemma, for if indeed there are rootless states which are not the resultants of good or bad action, how is it that such rootless states are not there and then included amongst active, and therefore “productive,” integral states from which resultants originate? The reason, as has already been shown, is that for states to be productive they must be accompanied by roots good or bad. Can it therefore be said that there exists a third category of integral conscious states which are classifiable as being “neither resultant nor productive of resultant?”

233. Such a category does indeed exist, and as such constitutes the final section of the third group of three in the *Mātikā* of the first book of the *Abhidhammapiṭaka*, *Dhammasaṅgani*. As with the other sections of the *Mātikā* it forms one of the great analytical divisions originated by the Buddha, whereby all mental and material phenomena may be classified in accordance with their innate qualities. Among the states in this particular category are included not only the three very simply structured rootless integral states now to be examined, but, as will be seen later, there exists a further series of groupings comprising certain other unique types of integral consciousness such as are experienced only by those who in this life have become freed from causal bondage and have thereby achieved full realization of *Nibbāna*.

234. Of these two broad groupings of states the three first mentioned are rootless, whereas the remainder which falls into the second category is accompanied by good roots. However, the feature which both possess in common is that as integral states they are neither the resultants of past action nor are they capable of producing resultants in the future. It is from this latter feature that they derive their general designation, for inasmuch as they possess no inherent ability whatsoever to produce or heap up any resultant tendency towards rebirth they are, in the sense of ACTION (*kamma*), classified as being non-productive or, as it is more usually called, INOPERATIVE (*kiriya* or *kriya*).

235. With the inclusion of this new group, the three basic categories, into one or other of which every single integral state is thereby able to be classified, are as follows:⁸⁷

1. RESULTANT STATES (*vipāka dhammā*).
2. STATES PRODUCTIVE OF RESULTANTS (*vipāka-dhamma-dhammā*, here called (productive) integral states).
3. STATES NEITHER RESULTANT NOR PRODUCTIVE OF RESULTANT (*neva-vipāka-na-vipāka-dhamma-dhammā*, here called INOPERATIVE STATES (*kiriya-dhamma*)).

236. Among the many integral states included in this final group are the three ROOTLESS INOPERATIVE (*ahetuka-kiriya*) functions of consciousness, which in *Abhidhammatthasaṅgaha*

⁸⁷ See also B.P.E., *Mātikā*, *Tikā* No. 3.

complete the whole section on ROOTLESS integral CONSCIOUS STATES (*ahetuka-cittāni*). These are classified in verse 11 as follows:

VERSE 11

UPEKKHĀ-SAHAGATAM PANCA-DVĀR ĀVAJJANA-CITTAM
TATHĀ MANO-DVĀR ĀVAJJANA-CITTAM
SOMANASSA-SAHAGATAM HASITIPĀDA CITTAN CETI
IMĀNI TĪNI PI AHETUKA-KIRIYA-CITTĀNI NĀMA

Meaning:

There exists: FIVE (*pañca*) DOOR (*dvāra*) ADVERTING (*āvajjana*) CONSCIOUSNESS (*citta*) ACCOMPANIED BY (*sahagata*) NEUTRAL (*upekkhā*) feeling. LIKEWISE (*tathā*) MIND (*mano*) DOOR (*dvāra*) ADVERTING (*āvajjana*) CONSCIOUSNESS (*citta*). There is ALSO (*ca*) CONSCIOUSNESS (*citta*) ACCOMPANIED BY—MENTAL PLEASURE (*somanassa-sahagata*) CAUSING THE APPEARANCE OF A SMILE (*hasituppāda*).⁸⁸ THESE (*imāni*) THREE TOGETHER (*tīni pi*) ARE KNOWN AS (*nāma*) ROOTLESS (*ahetuka*) INOPERATIVE (*kiriya*) integral CONSCIOUS STATES (*cittāni*).

237. When dealing with verses 9 and 10 it was shown how the arising of consciousness at any one of the five doors of physical sense is, with the cessation of that function, immediately succeeded by the arising of a further instant of consciousness performing the function of receiving: then, with the cessation of that, by the immediate arising of an instant of consciousness performing the function of investigating. From this description the impression may perhaps have been created of an entity, or indeed of five separate entities, called consciousness, each sitting in a state of permanent existence, watchful at its appropriate door of sense and all waiting like hungry spiders for the impingement of a suitable object. Such a state of affairs is by no means the case, for consciousness can in no sense whatever be considered either as an entity or as being permanent. Active consciousness does not even exist other than as a potentiality caused by past action, and therefore does not come into being until the instant at which contact between the sense stimulus and the sensitive surface takes place. Even so, that contact does not give rise straight away to sense consciousness, but to a function immediately prior to it; it is a function which may be looked upon as a precursor in that it disturbs and interrupts the smooth flowing instants potential to the arising of active consciousness. In so doing it sets the whole train of active conscious process in motion, and brings the appropriate sensitive surface into a state of readiness for the performance of its individual and specialized function.

238. Thus it is that when a sense stimulus, visible or otherwise, makes initial contact with a sensitive surface, there comes into being this preliminary function of consciousness which has bare awareness of the presence of impingement, coupled with a degree of attention which, figuratively speaking, turns towards the stimulus in the sense of “what is this?” At the same time though, this function, by virtue of its very existence, provides the essential condition for the arising of the appropriate sense consciousness itself to take place immediately upon its cessation. This precursory function is not, however, as with the three subsequent functions—sense consciousness, receiving and investigating—performed by a resultant state. Here there arises instead a structurally very simple ROOTLESS INOPERATIVE integral CONSCIOUS STATE (*ahetuka-kiriya-citta*) performing the single function of FIVE-DOOR-ADVERTING (*pañca-dvār āvajjana*): why, then, is it not a resultant? Because it’s arising is occasioned by the direct

⁸⁸ In the case of the arahanta only.

disturbance caused by the impingent stimulus in respect of the inherent potentiality in living beings towards activity of the conscious process. This potentiality, as has been seen, is due to past CRAVING (*tanhā*), ATTACHMENT (*upādāna*), and ACTION CUMULATIVE OF RESULTANT (*kamma-bhava*).⁸⁹

239. Of this conscious state Visuddhimagga says⁹⁰ that it has the General Characteristic of being the forerunner of eye-consciousness, etc., of having awareness of the visible and other (physical stimuli); the Inherent Functional Property of turning towards" (i.e., of adverting to those physical stimuli); the Resultant Appearance of a condition (or state) of facing the visible and other (physical stimuli, i.e., in the sense of paying attention to them), and, as Concurrent Footing; the interruption of bhavaṅga. Five-door-adverting is invariably accompanied by NEUTRAL FEELING (*upekkhā-vedanā*).

240. To digress now for a moment or two. In these four denotations of five-door-adverting, what in essence is meant by bhavaṅga? It will be remembered from what has been said previously,⁹¹ that as the outcome of CRAVING (*tanhā*) and ATTACHMENT (*upādāna*) there arises a stage in the causal series—paṭiccasamuppāda—which was there defined as "action cumulative of resultant tending towards rebirth;" this phrase being explanatory of the term *bhava*, often translated as "becoming" or "being." Without going into the matter in detail, it can from that definition be further said that not only is *bhava* the state or condition potential to rebirth respecting consecutive life periods, but also within those periods to the very thought moments themselves. For these cogent reasons it can be looked upon as manifesting itself as the INDISPENSABLE CONSTITUENT CONDITION (*aṅga*) or potentiality of BEING (*bhava*). As a function performed by certain resultant states this CONSTITUENT POTENTIALITY OF BEING (*bhavaṅga*) is given detailed consideration in later chapters of Abhidhammatthasaṅgaha; for the moment, therefore, it is sufficient to say that it represents the non-active instants of resultant consciousness maintaining the continuity of sentient existence. It is this so-called continuum which when disturbed and interrupted by stimuli, mental and material, is potential to the arising of the many active phases of the conscious process. With the cessation of such processes it maintains the absolute continuity between them throughout existence.

241. Bhavaṅga is quite frequently translated as "life-continuum;" this, however, can be most misleading, as it can appear to invest the whole function of bhavaṅga with a special constituent called "life." Here it is well to reflect that although in conventional usage the word "life" is perfectly satisfactory, Abhidhamma analysis explains existence as a whole as being a "continuity of contiguous causally related functions stemming basically from the activity of ignorance and craving." Consequently, rather than that the explicit function of bhavaṅga should be misinterpreted, it is generally more suitable to leave it untranslated.

242. The second rootless inoperative integral conscious state defined in verse 11 is called MIND-DOOR-ADVERTING (*mano-dvār āvajjana*), and rather as five-door-adverting was shown to be the precursor to the arising of whichever of the five types of sense consciousness was appropriate at that instant, so mind-door-adverting is the precursor to the arising of the very active FULL AWARENESS (*javana*) of the second phase of the conscious process. Mind-door-adverting is thus the final function performed by consciousness in the first phase of active conscious process, and as such performs a very necessary and important part. Why is it so important? It is at this stage that the purely mental concept of the object can be said to be fully

⁸⁹ See pars. 112-122 inc.

⁹⁰ See also Ppn. p. 513.

⁹¹ See pars. 112-122 inc.

determined. Here, all preliminary work with regard to the original stimulus has been completed, all the data collected and arranged in such a way that it is ready to be fully known, recognized and appreciated throughout the second phase of the conscious process; that is, in the phase in which a being is ordinarily considered to be properly "aware" or "conscious" of the object.

243. The function of mind-door-adverting is, however, quite unique, for although it appears to do but one thing, that one thing does in practice have two aspects. The first is indeed that of monitoring all the information which INVESTIGATING CONSCIOUSNESS (*santirana-citta*) has elicited from the original sense data. From this, by combining awareness of the sense data with comparative data based upon past experience, it builds up a conceptual image of the object; this it does to a point where it can be said that the data derived from the original bare sense stimulus has been fully organized and correlated. At this juncture the fully conceptualized mental object is said to be "determined," that is, in accordance with past experience and associations the bare stimuli are determined as being for example a cup, a house, a ship, a person and so on. Here the concept is complete and ready to be experienced fully. When performing in this first way with data derived from objects of sense, mind-door-adverting is customarily known as DETERMINING CONSCIOUSNESS (or *votthapana citta*); in its second aspect, however, this function always retains its basic title of mind-door-adverting. What, then, is this second aspect?

244. It is quite clear that marshalling the data and determining the nature of the five physical sense stimuli up to the stage of their being ready to be experienced as fully conceptualized objects of sense, is not the only kind of correlation that can occur immediately prior to the arising of full awareness. One knows very well from experience that there are other objects besides those of sense; there are mental objects, mental images, abstract thoughts, thoughts connected with objects of physical sense by way of recollection, of which one says, "I can see it in the mind's eye." Because of this it is usual to refer to forms of thought, quite cut off from direct and present operation by the five physical senses, as having ideational objects. At what point, therefore, do such IDEATIONAL OBJECTS (*dhamm ārammāpa*) come into being?

245. When from the expression "mind-door-adverting" one extracts the term "mind-door," it is clear from its comparable form that it is being used in respect of mental stimuli much as the term "five-door" in "five-door-adverting" is used in respect of the five physical stimuli. This amounts to considering mind-door as the point of arising of consciousness on an ideational object just as the five organs are respectively the points of arising of consciousness on the five appropriate physical objects. In the case of these five physical objects it has been shown that several preliminary stages occur before the final conceptualized object of sense is evolved in terms of its relationship to past experience by the DETERMINING (*votthabbana*) aspect of mind-door-adverting. From whence is this past experience derived?

246. Without in any way entering into the details of the many and complex relationships involved, it is sufficient at this stage to say in accordance with the method of Abhidhamma (i.e., in accordance with the final section of the Abhidhammapiṭaka entitled Patthāna, and its highly summarized form in chapter 8 of Abhidhammatthasaṅgaha) that because of there being an absolute and unbroken RELATIONSHIP OF CONTIGUITY (*samanantara-paccaya*) between the serial instants of both active and non-active integral consciousness, there exists at the same time an unbroken continuity of what might be termed the potential of cumulative experience derived from past action. In consequence of this, when consciousness arises performing one of its seemingly dual functions within mind-door-adverting, due either to an initial stimulus impinging upon a door of sense which has then passed through its appropriate subsequent stages (whereupon mind-door-adverting is called determining consciousness), or to a stimulus

that is itself directly related to that potential of cumulative experience of past activity—in a word, to recollection—, mind-door-adverting correlates either class of stimulus into its fully regulated form prior to its being experienced by the subsequent function of full awareness.

247. In this way mind-door-adverting, although but a single undivided function, performs the apparently dual role of determining and mind-door-adverting. However, by whichever name it is known and irrespective of the nature of the objects it takes, mental or physical, it is an entirely mental state and is the proximate cause of the arising of full awareness. Bearing in mind the two sources of stimuli that cause the arising of mind-door-adverting to take place, its four denotations are so worded as to demonstrate this point. Thus Visuddhimagga says:⁹² the General Characteristic is awareness of the six objects. Of the Inherent Functional Property it says: as to the duty it performs in respect of the five (sense) doors and mind-door, there is determining and adverting (respectively). The Resultant Appearance is: that same condition (i.e., determining or adverting), and the Concurrent Footing: the respective discontinuance of either rootless-resultant-mind-consciousness-element (i.e., investigating consciousness = *santirana-citta*) or of bhavaṅga.

248. The mention here of bhavaṅga emphasizes the importance of this function in maintaining continuity between each individual course of active conscious process. This is particularly so with regard to the cumulative experience potential mentioned previously.

249. The third and final member of this group comprising ROOTLESS-INOPERATIVE-integral-CONSCIOUS STATES (*ahetuka-kiriya-cittāni*) is known as hasituppāda-citta. Literally hasituppāda means the causing of the appearance or coming to be of a smile; but whereas this and other states accompanied by PLEASANT MENTAL FEELING (*somanassa-vedanā*) can cause smiling to take place, this rootless-inoperative-hasituppāda-citta arises only in one who has achieved full realization of Nibbāna in this present life, one who is FREE FROM THE DEFILEMENTS (*khīnāsava*) and who, by reason of that, is a PERFECTED ONE (Pāli: arahanta, arahā. Skt., BSk.: arhat, arhant, arahant).

250. The four denotations of this state given in Visuddhimagga⁹³ are as follows. The General Characteristic is: (full) awareness of the six objects. Of the Inherent Functional Property it says: as to the duty it performs, there is in the case of arahantas, in respect of things unsublime, the appearance of a smile. The Resultant Appearance is: that same condition (i.e., a smile). Its Concurrent Footing: invariably the heart base. This state is always accompanied by pleasant mental feeling.

251. Referring again to its Inherent Functional Property, it will have been noticed that the smile of the arahanta arises IN RESPECT OF THINGS UNSUBLIME (*anularosu vatthesu*); what is meant by that? In the case of the arahanta it is to be appreciated that for such a one, IGNORANCE (*avijjā*) and therefore CRAVING (*tanhā*) no longer exist, both having been completely supplanted by the penetrative understanding that sees things as they are in absolute reality. As the result of this, the attitude to things of the world is quite different. The ordinary average man, because of his absence of knowledge of SUFFERING (*dukkha*), as also of the CAUSE OF SUFFERING (*dukkha-samudaya*), reacts virtually automatically to the objects of the five senses and the mind only in accordance with craving. The arahanta, however, looks upon objects quite differently, this because of his complete understanding, not only of the nature of suffering and its cause but also of the CESSATION OF SUFFERING (*dukkha-nirodha*); this latter because of his having traversed the entire WAY LEADING TO THE CESSATION OF

⁹² See also Ppn. p. 513.

⁹³ See also Ppn. p. 513.

SUFFERING (*dukkha-nirodha-gamini-ṣaṭipadā*). With ignorance and craving utterly eradicated, objects are in consequence no longer grasped after, but in the light of that complete understanding are seen only as obstacles and stumbling blocks to those who have not traversed that way. Thus, when he reviews them causally, he smiles, comprehending them in their true relationship. When he makes use of them, he smiles, knowing them to be properly applied to the advancement of others. In reflecting upon action and its results, past and future, he smiles, understanding the nature and course of attainment and of omniscience. Thus, understanding is the salient feature. For example, in the presence of a heap of bones, or a skeleton, the average man might well be displeased, worried or even frightened; all bad states. In contrast, the arahanta sees clearly the working of the causal law, impermanence, suffering, and absence of soul, and by virtue of that penetrative understanding there arises the smile of one who understands by way of absolute truth.

252. Thus, whereas the average man is influenced by superficial appearances, the Perfected Ones perceive that which is deep, that which is subtle; consequently, when it is said that the arahanta smiles in the presence of the UNSUBLIME (*anulāra*), it means that at that time he is cognizant of that which therein is SUBTLE (*anolārika*). In respect of this the Commentaries make use of both meanings.

253. With the completion of this small group of inoperative states, the entire section of rootless states, both resultant and inoperative, is thereby finalized and its total stated in verse twelve.

VERSE 12

ICCEVAM SABBATHĀ PI ATTHĀRAS ĀHETUKA CITTĀNI SAMATTANI

Meaning:

THUS (*iccevam*) FROM EVERY ASPECT (*sabbathā pi*) the EIGHTEEN (*atthārasa*) ROOTLESS (*ahetuka*) integral CONSCIOUS STATES (*cittāni*) are FULLY COMPLETED (*samattāni*).

254. In connection with this passage one small point needs explaining. Although verses 9, 10, and 11 are all concerned with rootless states of one kind or another, it will have been noticed that whereas in the summary lines of verses 10 and 11 this rootlessness is clearly stated regarding good resultants and inoperative states respectively⁹⁴ it is not so stated for bad resultants.⁹⁵ Why is this so?

255. The reason is quite straightforward and depends upon the general existence of resultant states both with and without roots, and of inoperative states also, both with and without roots. In consequence of this where two quite separate categories occur, as in the cases of good resultants and of inoperatives, it is clearly essential to specify the group to which they belong. The position respecting bad resultants is quite different, for since such states are morally weak they produce only one class of resultant, rootless resultant.⁹⁶ Under such circumstances it is therefore quite unnecessary to make a special point of specifying that rootlessness other than by including all bad resultants within that general classification by virtue of the nature of their activity.

⁹⁴ See pars. 207 and 236.

⁹⁵ See par. 203.

⁹⁶ See par. 202.

256. As in the case of the twelve bad (productive) integral states, where a summarizing mnemonic stanza was included for ready reference,⁹⁷ so at the conclusion of rootless states, verse 13 performs a similar function.

VERSE 13

SATT ĀKUSALA-PAKANI
PUNNA-PĀKĀNI ATTHADHĀ
KRIYA-CITTĀNI TINĪTĪ
ATTHĀRASA AHETUKĀ

Meaning;

There are SEVEN (*satta*) RESULTANTS (*pākāni*) of BAD (*akusala*) states, MERITORIOUS (*punna*) RESULTANTS (*pākāni*) are EIGHTFOLD (*atthadhā*). The INOPERATIVE (*kriya*) integral CONSCIOUS STATES (*cittāni*) are THREE (*tīni*), THUS (*iti*) there are EIGHTEEN (*atthārasa*) ROOTLESS (*ahetuka*) states.

257. That completes the section dealing with rootless integral conscious states.

⁹⁷ See par. 171 ref. verse 8.

ABHIDHAMMATTHASAṄGAHA Talk No. 5 (Part 2)

258. When consideration was being given to the twelve bad, unskilful states, it was a relatively straightforward matter to appreciate that it is not in the interests of progress towards realization of the true nature of things to make a practice of strengthening the three bad roots of greed, hatred, and delusion, dependent upon which such states arise. This, quite apart from any of the technicalities involved, would have been seen as being a reasonable moral view, and quite in accord with what is ordinarily called religious practice. On the other hand, when giving consideration to the eighteen rootless integral states, such a firm opinion may not so easily have been formed, the reason being that their existence as states may well seem remote and obscure and to lack the reality possessed by the bad states. As the result of this, and because the focus of attention is thereby necessarily directed towards principles unfamiliar and not so readily grasped, the question may well be asked, "What has all this probing into the working of the senses to do with the practical application of the Buddha's Teaching; or indeed, in what way is it relevant to religious matters at all?"

259. Here it is well to reflect not only upon what has been said earlier of the two sources from which the meanings of the word "religion" derive, but also, because of this, upon the reasons why the teachings of the Buddha differ so radically from other systems of thought and practice.⁹⁸ In this, as has been seen, the all important consideration is the goal of achieving absolute penetrative insight; an insight which, far from accepting the worlds of sense and mind at their face values, has striven to understand them in an ultimate sense by means of properly directed intention, effort, energy and exertion. It is in this process of gaining supreme understanding that the darkness and confusion of ignorance and craving is recognized and swept away, for it is the activity of this very ignorance and craving which, over immeasurable periods of time, has reacted to objects of sense and mind in such a way as to reinforce its strength and activity rather than to clear it away.

260. But to consider now the relevance of those rootless integral states in the practice of the Buddha's Teaching. Here the whole matter of the importance of analysis and of the analytical approach comes into the question, for, as has been said previously, the Buddha has from the earliest period been regarded as an analyst, and his teachings as ANALYTICAL DOCTRINE.⁹⁹

261. When the term analysis is used it frequently gives rise to the idea of dry-as-dust scholarship, dealing only with dull facts and as being quite devoid of any glimmer of real understanding or innovation. Unfortunately this view is all too frequently quite correct, but it is a pity that all analysis should be so considered, for its root meaning is associated with loosening and releasing, and not with a blunting of comprehension. Accordingly it is defined as the resolution of anything complex into its simple elements for the purpose of determining its components. Here, however, there comes the need for a deeper interpretation of analysis as a whole, for if the mere determination of component parts for the sake of producing lists of words is all that is meant to be accomplished, such lists are as they stand of very little value; that, indeed, is the dry-as-dust type of analysis. If on the other hand those lists of words are pondered on, their relationships with each other understood and from that the whole nature of their complexity resolved, its mystery dispelled, and a proper appreciation of its purpose and implications gained, then, and only then, can it be said that genuine analysis has been achieved. It is at this point that there is, as it were, a coming to know of something previously unknown.

⁹⁸ See pars. 15-18 inc.

⁹⁹ *vibhajja-vāda*; see also par. 19.

262. So is it with the application of the analytical methods of the Buddha's Teaching. As it stands, that Teaching is a summary of the knowledge of one who has analysed to the full, that is, penetrated to the full, and who has understood completely. If, therefore, analysis of one's everyday behaviour is permitted to go only so far as compiling lists of integral states, mental concomitants, functions, relationships and so on, this is in consequence but a small part of the proper process of analysis. The far larger part does indeed consist in understanding what has given rise to those component parts, of comprehending the nature of their relationships and from that, by seeing all the processes disentangled, to derive therefrom not just a knowledge in theoretical terms of how they operate, but to gain the understanding that comprehends how all is to be controlled and regulated. Thus it is that over and above any preliminary analysis showing structure and components, it is essential that there be developed the analysis of understanding.

263. With this in mind, together with the knowledge of the intensely practical nature of the whole of the Buddha's Teaching, consider what has been said of the rootless resultants of good or of bad action. First of all it can readily be appreciated, just from the classifications themselves, that according to the kind of action performed in the past in respect of any particular object, there comes to be a virtually automatic reaction of a similar kind when a comparable object is encountered in the present. Secondly, from what has been explained, it can be seen that this is due almost entirely to the fact that the resultants of those past actions perform, at the present moment, most of the functions of the first phase of the active conscious process. Thirdly, it is plain from this that in the absence of watchfulness there is a very great possibility of the general ethical qualities of this first phase being to some degree maintained in the second phase, the productive phase.

264. If these interrelationships have been properly recognized it is reasonable to apply one's own further constructive analysis to seek out the implications. It is clear that the implications can indeed be severe; however, the general inference to be drawn from such analysis is that if extreme watchfulness is maintained as to the character of action performed, be it mental, vocal, or bodily, then to that degree there is regulation of the character of future resultant. If, thus, by reason of such analysis it is understood that present unskilful action does in effect make preparation for further unskilful action by way of resultants that operate as part of the normal course of active conscious process, some insight has been gained into why it is that bad states have no tendency to rise to progressive levels, but throughout their practice fall easily to lower and deeper degrees of unskilfulness. If as a corollary to this it is likewise recognized that good, skilful action, by virtue of its resultants, prepares the way for further good, skilful action, insight has thereby been gained as to the manner in which falling to lower conditions is to be avoided and forward progress assured.

265. In this way then, it becomes apparent that if by searching and observation there can be uncovered the details of the way in which certain ostensibly very ordinary occurrences take place, a much deeper understanding of the way they really affect day to day existence can often also be discovered. So it is in the case of the manner in which the various frictions of the active conscious process are originated, come to be and are causally related in operative sequence. In the ordinary way it is probable that very little thought is given to such seemingly unimportant matters; nevertheless when, as the Buddha has done, such unsuspected detail is made so abundantly clear, then, because of that additional knowledge, the answer becomes much more apparent as to why certain types of behaviour and practice are more suitable to progress than are others. In this respect, then, it can be seen that because of the very important functions they perform in the operation of the active conscious process by way of any of the six doors, a

knowledge and understanding of the working of rootless integral conscious states, far from being irrelevant, is indeed strongly relevant to the practice of the Buddha's Teaching.

266. A suitably structured knowledge of facts concerning the nature of MENTAL QUALITIES (*nāma*) and MATERIAL QUALITIES (*rūpa*) is therefore of great importance, but should be gained for the purposes of understanding "why" rather than "how" such and such a condition occurs. Consequently, in applying the mind to the study of Abhidhamma—with its enormous store of information and methods of analysis—it is not knowledge for the sake of knowledge that is to be sought, but for that far deeper and penetrating state of understanding which, under particular circumstances, can arise because of the application of that very knowledge.

267. In this connection the expression "particular circumstances" has been used to bring to mind certain points regarding knowledge and the understanding that proper development will cause to spring from it. When in respect of understanding, the phrase "coming to see things as they are in ultimate reality" is used, it is important to grasp what is meant; for here, "seeing" does not in any way imply that with the gaining of understanding there is any change in what is experienced physically. As is apparent from the functions performed by the rootless resultants of either good or bad states, the eye sees the visible, the ear hears the audible, the nose smells the odorous, the tongue tastes the sapid, and the body touches the tangible. These objective stimuli are entirely MATERIAL (*rūpa*) in nature, and by way of CONTACT (*phassa*) with the appropriate organ of sense are instrumental to the arising of conscious states. This is a perfectly straightforward and regular process and is governed by particular laws. Whether an object is seen by a being of low development or by one of supreme development, the actual representation of the object in respect of its basic characteristics and conventional identification remains unchanged.

268. The realization of that object in an ultimate sense is however a very different matter, for here it depends on a knowledge that the value, importance, apparent function, desirability or indeed any quality conventionally ascribed to that object, exists only because of the ever present craving that arises in all but the utterly Perfected Ones. In this latter case, there being no ignorance or craving whatsoever to cloud the clarity of experience, conventionality is both seen and seen through, the true nature of the object in terms of its essentials is appreciated, and its potentiality in the presence of ignorance to cause the arising of craving recognized.

269. In the Pāli language the word "avijjā," as also its English equivalent, "ignorance," have in their respective derivations the meaning "absence or want of knowledge." What kind of knowledge? It is clear from what has been said of the understanding which under "particular circumstances" can arise from knowledge, that it cannot refer just to random knowledge. This is so, for it is from knowledge that pertains to wisdom, that wisdom and understanding are derived.

270. IGNORANCE (*avijjā*) being absence of KNOWLEDGE (*vijjā* or *ñāṇa*) manifests itself as dullness, delusion and stupidity, besides being as well fundamental to all greedy and hateful states. Indeed, in the case of these last two, bare factual knowledge can itself, in terms of progress, often be classed as a mere manifestation of ignorance. This is well shown in the story of the snake, as told in the Alagaddūpamasutta of Majjhima Nikāya, and in the Commentary Atthasālini¹⁰⁰ where even knowledge acquired from study of the Buddha's Teaching, when quoted by certain stupid people, "for the purpose of annoying others or of freeing themselves from the criticism and scoffing of others" is conducive only to disadvantage and misery. The reason being that such study has been done without intelligence, that is with ignorance, and

¹⁰⁰ See M.L.S. vol. 1, p. 172, and Exp. p. 29, also the talk "Abhidhamma Applied" p. 10.

because of this has been applied at the promptings of greed and hatred. From this it is apparent that the possession of knowledge as a collection of isolated facts, is no indication whatsoever of advancement towards wisdom and insight.

271. There is, however, another aspect, for where the bare facts of knowledge are marshalled and correlated with the specific aim of developing understanding, and thereby of observing a mode of life conducive to such development, there does indeed exist a level of mundane understanding whereby knowledge does to some extent move away from the direct sphere of influence of ignorance, and to that extent is less affected by the insidious power of that root. Further than this, where that existing knowledge is probed to disclose a yet deeper knowledge in respect of, for example, the implications of the GENERAL CHARACTERISTIC (*lakkhana*), the INHERENT FUNCTIONAL PROPERTY (*rasa*), the RESULTANT APPEARANCE (*paccupatthāna*) and CONCURRENT FOOTING (*padatthāna*) of states, such derived knowledge is knowledge that can pertain to WISDOM (*paññā*) and INSIGHT (*vipassanā*). Why is this so? Because it is knowledge directed towards correctness, that is, to the attainment of PURITY OF VIEW (*ditṭhi-visuddhi*).

272. However, the real virtue of such true wisdom and insight is that it penetrates more deeply still, and sees in those four denotations nothing other than the THREE CHARACTERISTICS (*ti-lakkhanā*): IMPERMANENCE (*anicca*), UNSATISFACTORINESS, or SUFFERING (*dukkha*) and ABSENCE OF ENTITY or SOUL (*anattā*). When such penetrative insight is achieved, the utter uprooting of ignorance is imminent, understanding has ceased to be MUNDANE (*lokiya*) and has thereby become SUPRAMUNDANE (*lokuttara*). With the final uprooting of ignorance there then exists in the higher wisdom of the Perfected One, the arahanta, the full knowledge, and insight of the FOUR NOBLE TRUTHS (*cattāri ariya-saccāni*): viz. SUFFERING (*dukkha*), the CAUSE OF SUFFERING (*dukkha-samudaya*), the CESSATION OF SUFFERING (*dukkha-nirodha*), and the WAY LEADING TO THE CESSATION OF SUFFERING (*dukkha-nirodha-gāmini-paṭipadā*).

273. In this connection, though, Purity of View is not the sole consideration; for wisdom and understanding, closely dependent though they are upon that purity, are not dependent upon it alone. Nor, indeed, does Purity of View itself arise in isolation from all other considerations. PURITY OF VIEW (*ditṭhi-visuddhi*) can come to be only where PURITY OF CONDUCT (*sīla-visuddhi*) and PURITY OF CONSCIOUSNESS (*citta-visuddhi*) are present in comparable degree. However, direct reference to these three purities is usually made only in connection with the highest levels of progress, at a point when ultimate realization is near at hand. How, then, are they to be understood from a more elementary point of view?

274. Purity of Conduct refers to activity which, in respect of progress towards the ultimate goal of perfection, is SKILFUL (*cheka*), WHOLESOME and GOOD (*kusala*). Such action is called MORAL PRACTICE (*sīla*).

275. Purity of Consciousness refers to the cultivation of integral conscious states purged of the Hindrances, and of all demerit, that are directed and developed specifically to the purpose of gaining penetrative insight. Such cultivation is called MENTAL DEVELOPMENT (*bhāvanā*).

276. Purity of View, which can arise only in conjunction with the previously mentioned purities, means the gradual, step by step attainment of knowledge and understanding commensurate with that moral practice and mental development. Such attainment is called WISDOM (*paññā*).

277. Thus it is that the purely practical problem of making progress towards freedom from causal bondage, and to ultimate realization of Nibbāna, depends fundamentally upon the

proper cultivation of the threefold interdependence of MORAL PRACTICE (*sīla*), MENTAL DEVELOPMENT (*bhāvanā*) and WISDOM (*paññā*).

278. The practical aspect of the Buddha's Teaching being so very important, it is to be expected that in connection with Abhidhamma studies every possible condition conducive to forward progress is fully described and categorized in accordance with its particular function. This is indeed so, and although at this juncture Abhidhammatthasaṅgaha is still giving attention specifically to integral CONSCIOUSNESS CHARACTERISTIC OF THE PLANE OF SENSE DESIRE (*kāmāvacara-cittāni*), the following stanza, introducing good states as a whole, nevertheless indicates the possible totals of all such states irrespective of plane or function.

VERSE 14

PĀP ĀHETUKA-MUTTĀNI
SOBHANĀNĀ TI VUCCARE
EKŪHA-SATTHI CITTĀNI
ATH EKA-NAVUTĪ PI VĀ

Meaning:

FREE (*muttāni*) of EVIL (*pāpa*) or of being ROOTLESS (*ahetuka*) THE BEAUTIFUL (*sobhanāni*) states ARE EXPRESSED (*vuccare*) THUS (*iti*); there are FIFTY-NINE (*ekuna-satthi*) integral CONSCIOUS STATES (*cittāni*) OR (*atha vā*) NINETY-ONE (*eka-navuti*) IN ALL (*api*).

279. Two points are to be observed in this stanza, the first being the use of the term "beautiful;" the second the two different values, 59 and 91 accorded to the totals of such states. With regard to "beautiful" this represents the Pāli word "sobhanā," a term which means shining, splendid, adorning, radiant, illuminating and good; moreover, in its affinity with another Pāli word, *subha*, it has the connotation: auspicious, fortunate, pleasant. In this way, therefore, when the epithet "beautiful" is applied to the integral states that remain to be described, all the qualities mentioned are equally applicable. What is the reason, though, for so describing states?

280. Initially this depends upon the fact that quite independent of the various categories into which these states fall, they are nevertheless always accompanied by GOOD ROOTS (*kusala-hetu*) appropriate to their category. Because of this the kamma, i.e., the action, associated with such states as are productive, is never bad or unskillful; on the contrary, by reason of that root structure, it is ever associated with generosity and goodwill and often with knowledge and wisdom. As the outcome of such favourable activity the RESULTANTS (*vipāka*) produced in addition to the rootless types already listed in verse 10 are, in contradistinction to those, accompanied by good roots and perform important functions both in respect of present existence and in the process of functional continuity called rebirth. Then, quite apart from any such productive action and its resultants, there exist besides the many INOPERATIVE (*kiriya*) integral states having good roots. These are the everyday conscious states experienced only by the Fully Perfected Ones, the arahantas, who by virtue of their perfection can perform no thought, speech or action which is in any way bad or unskillful; moreover, because of this, they are ever GENEROUS (*alobha*) in striving with WISDOM (*amoha*) and GOODWILL (*adosa*) to help those who wish seriously to achieve progress in understanding. It is for such reasons that the states referred to are called BEAUTIFUL (*sobhanā*) and are thereby regarded as being auspicious, splendid, radiant, and good.

281. In connection with the qualities such states represent, there is a sutta in the Aṅguttara Nikāya called Sobhanasutta.¹⁰¹ In this the Buddha states that bhikkhus and bhikkhunīs who are possessed of morality and great learning; men and women who as lay supporters are possessed of confidence (born of knowledge); all of whom, both of Sangha and laity, are accomplished in wisdom, possessed, of discipline, furnished with knowledge accompanied by confidence and mental pleasure, who are holders and supporters of the Teaching and who live and move in conformity with the Teaching: such, ILLUMINATE (*sobhati*) the ORDER (*Sangha*) and are indeed THE LIGHT OF THE ORDER (*Sangha-sobhanā*).

282. Very naturally the qualities enumerated in this sutta are characteristic of the integral states involved in thought, speech, and action directed only to good purpose. Thus again it is for such reasons that the remaining 59 or 91 conscious states are called BEAUTIFUL (*sobhanā*); but why are both 59 and 91 given as the numbers of good states?

283. Here there is no confusion whatsoever in the stating of these two values, for, as will be seen in detail later, they depend on the method of approach adopted in attaining PENETRATIVE INSIGHT (*vipassanā*). Stated briefly, where such insight is achieved by means of the application of analysis as the method of MENTAL DEVELOPMENT (*bhāvanā*) leading to the gaining of penetrative WISDOM (*paññā*), such insight is known as DRY INSIGHT (*sukkhavipassanā*). Where, however, the gaining of insight is assisted by and finally attained in the practice of MENTAL DEVELOPMENT (*bhāvanā*) directed to stability and CALM (*samathā*) with the specific achievement of jhāna, such insight is known as the INSIGHT OF CALM (*samathavipassanā*). In the case of “dry insight” the possible beautiful states are numbered as 59.¹⁰² In the case of “insight of calm” the additional states of jhāna increase this figure to 91. It should, however, be emphasized that in both cases the nature of the actual penetrative insight is precisely the same.

284. In the preceding verses, up to and including verse 13, Abhidhammatthasaṅgaha has enumerated a total of thirty integral states. Of these, twelve are productive, arising as they do directly from the three bad roots; the remainder consist of eighteen rootless states, comprising fifteen which are the resultants of good or bad action together with three that are purely inoperative. In verse 14, good states were introduced, and it is of these, the beautiful states, that the remaining verses of the first chapter of Abhidhammatthasaṅgaha speak.

¹⁰¹ A., the section of fours, sutta no. 7 of the first group; see also G.S. Vol. II, p. 8, “Illuminates.”

¹⁰² The actual applicability of the various states will be discussed later.

ABHIDHAMMATTHASAṄGAHA Talk No. 6 (Part 1)

285. In order that in continuation of its opening chapter Abhidhammatthasaṅgaha may bring to completion the first of the four categories initially dividing integral conscious states,¹⁰³ it now deals with BEAUTIFUL CONSCIOUSNESS CHARACTERISTIC OF THE PLANE OF SENSE DESIRE (*kāmāvacara-sobhanā-citta*).

286. As already explained, “beautiful consciousness” can first of all be defined as any activity which in respect of thought, speech or bodily movement has no association whatsoever with the three bad roots of GREED (*lobha*), HATRED (*dosa*) or DULLNESS AND DELUSION (*moha*), A second point is that no “beautiful state” can be ROOTLESS (*ahetuka*). Provided, therefore, that a conscious state complies with these conditions it is said to be auspicious, splendid, radiant, and good, and is thereby referred to as BEAUTIFUL (*sobhanā*). In observing these conditions, what is the actual basis upon which such states come to be?

287. The nature of the three bad roots has already been described in some detail,¹⁰⁴ and it is by using those same roots as the fundamental point of reference that “beautiful states” are shown to be based upon distinctive and characteristic structures in every way the complete antithesis of such roots. Thus the direct opposite of GREED (*lobha*) is ABSENCE OF GREED (*alobha*), that of HATRED (*dosa*) is ABSENCE OF HATRED (*adosa*) and the direct opposite of DULLNESS AND DELUSION (*moha*) is ABSENCE OF DULLNESS AND DELUSION (*amoha*). With regard to the other invariable condition, that “beautiful states” cannot be ROOTLESS (*ahetuka*), the direct opposite here is that they must be POSSESSED OF ROOTS (*sahetuka*).

288. The Buddha’s Teaching as expressed here in Ven. Anuruddha’s Abhidhammatthasaṅgaha, is frequently very succinct, nevertheless—as in the matter now under review—when considered carefully is most revealing. Thus, in stating the basis of good purely in terms negating the essential qualities of the bad roots, but at the same time emphasizing the necessity for a root structure appropriate to “beautiful states,” it is clear that anything definable in whatsoever degree as greedy, hateful, deluded or rootless, is by the terms of that very definition utterly excluded from any state capable of being regarded as “beautiful.”

289. Although this argument may at first appear to use a negative approach, further examination shows that to be far from correct. The reason is that as a method it has the fundamental advantage of adapting an easily definable basic standard, or zero point, above which the relative values of other states may be determined. As a method of analysis, therefore, it is positive. As an example, it is comparable to using the condition of absolute blackness as the zero standard, above which any level of brightness may be assessed.

290. Blackness, when considered in its strictly technical sense, and not as a relative term denoting darkness or dimness, is a condition of complete finality, an absolute state of non-light. It is therefore a phenomenon which, provided that this strictly technical sense is observed, ceases to be in the presence of light, no matter how minute that degree of illumination may be. In a conventional sense one might well say that darkness still abounds, but that is only another way of saying there is little light, a condition quite other than blackness. Similarly, where the three BAD ROOTS (*akusala-hetu*) are adopted as the basic zero standard, any degree of good must for the duration of its existence represent the complete absence of those bad roots.

¹⁰³ See pars. 44-51, ref. Abhi/S. verse 3.

¹⁰⁴ See pars. 69-72, greed: pars. 142—145, hatred: pars. 154—159, dullness and delusion.

291. On that basis, therefore, it is axiomatic to say that there cannot exist any conscious state wherein good roots and bad roots coexist. Bad states are bad in that they spring from bad roots alone. To that extent they can be equated with the zero point of utter blackness. It is because of this limitation that they cannot rise above themselves or aspire to morally progressive levels. In sharp contrast, good states are beautiful and auspicious in that they exist not just by the seemingly negative reason of the absence of bad roots, but because of the existence of their own distinctive good roots which by their very presence preclude and utterly negate the occurrence of bad roots. Thus no matter how minute the degree of goodness may be, its presence is to be compared with light dispelling completely the utter finality of blackness. Because of this non-limitation the proper development of good states leads ultimately to the highest levels of moral progress and penetrative insight.

292. With regard to this non-coexistence and non-concurrent arising of good states and bad states, a clear distinction needs to be emphasized. When, for example, the expression, "There is both good and bad in him" is used, it does not mean that good states and bad states are occurring at one and the same time. On the contrary, it means that when bad states arise they do so only by way of bad roots, and that when good states arise they do so only by way of good roots. Thus, when activity is occasioned by bad roots, to that extent there is badness; when activity is occasioned by good roots, to that extent there is goodness. Moreover, in both cases, and strictly in accordance with causal law, the outcome of any such activity will bear its fruit as a resultant state performing its appropriate function at an appropriate time.

293. Where, as in the vast majority of cases, the activity of beings displays evil states and meritorious states arising sporadically, others, in considering what they observe of that activity, tend to assess it in terms of averages viewed from their own instantaneous standpoint of good or evil. Within that framework they offer judgment such as, "There is both good and bad in him," sometimes qualifying it by adding, "he is by no means as good as people say," or indeed, "he is not altogether bad." In what way, then, are the GOOD ROOTS (*kusala-hetu*) to be described?

294. Further consideration is needed here, for as has already been seen the Piṭakas more usually refer to good qualities not by the use of positive expressions of good, but in terms demonstrating the absence of their bad, unskillful counterparts; why should this be so? This depends upon the important feature of mundane existence whereby, although individual beings may be possessed of much information and knowledge, it may be said generally that such knowledge is very rarely of the kind that understands the true nature of things by way of penetrative insight. Quite the contrary, most of it depends upon the causal fact that the activity of existence arises ultimately upon a complete ignorance of the true nature of things. On account of the activity of this ignorance, there are VIEWS (*dittṭhi*) which, with the consequent absence of any such penetrative insight, take the form of theories and hypotheses based upon which there is the appearance of a solid foundation providing a reasonable and convincing explanation for things. It is in connection with such theories and hypotheses that Vibhaṅga, the second book of the Abhidhammapiṭaka, says, "... wrong view arises in him firmly as truth."¹⁰⁵

295. Thus, because of this insidious underlying condition of ignorance which begets craving, beings are confused, deluded, and obsessed by-wrong views, VIEWS (*dittṭhi*) which are evolved by them and to which they adhere because they appear to possess the firmness of truth. Such for example are the many and varied hypotheses which propound the concept of an individual ESSENCE, SELF or SOUL (*atta*), a concept from which a corollary view naturally arises forming

¹⁰⁵ See B.O.A. par. 948.

the ideas of "I," "me," and "mine." Then there are views which hold as valid the concept of PERMANENCE (*nicca*); a view which in association with that of self or soul gives rise in turn to the idea of "my past life," "my present life," "my future life." It is these two views which, bonded as they are by CRAVING (*tanhā*), seek always after PLEASURE (*sukha*), both bodily and mental. As a trio they act as it were as a focal point, an assembly point, for the sixty-two views which, as manifestations of ABSENCE OF KNOWLEDGE (*avijjā*), arise as deviants from perfect understanding of ultimate truth. It is an extensive explanation of these views that constitutes a most important section of the first sutta of the Dīgha Nikāya, entitled Brahmajāla Sutta.¹⁰⁶ It speaks of four eternalistic views, four partial eternalistic views, four finite and infinite theories, four views based on equivocation (eel-wriggling views), two theories of occurrences arising without cause, thirty-two hypotheses concerned with perception and non-perception, seven annihilationistic theories and five views concerning Nibbāna in the present existence; making in all sixty-two views not in accordance with ultimate truth.

296. In order to emphasize still further the bondage in which beings are held by views, the following simile may be useful. Rather as certain species of fish, which live out their entire lives surrounded by, immersed in and permeated by the waters of the deepest, darkest oceans, would find it difficult even to conceive of any alternative kind of existence, so also beings who are surrounded by, immersed in and permeated by ignorance, craving and the views arising therefrom, find it difficult to possess or even conceive of the idea of emancipation from such theories as form their normal mental habitat.

297. This may suggest a fatalistic approach to existence, one allowing no possibility of progress. However, as a simile it is intended to present a picture of the effects of views where they are allowed to become dominant to the extent of excluding all real understanding. Fortunately, though, the simile can be applied in another way showing that in the presence of example and effort the dominance of view can indeed be broken down; that is, provided that there is appropriate personal action. In this way the hopelessness of fatalism disappears, completely supplanted by the Buddha's Teaching with regard to individual effort and its results.

298. Consider, therefore, those marine creatures which live in shallow waters where light is present, and which from time to time rise to the surface or even for a while remain in the air and sunlight; such creatures, even though water is still their customary habitat, will for those times spent out of it be aware that there is something beyond their usual home, and may even attempt to dwell there. So also is it with beings who, although still dwelling imbued with ignorance and craving nevertheless contact views near to truth; and who, as a result of that, are able from time to time, by the intentional practice of skilful states, to experience even if only for short periods, the clarity, brightness and freedom which arises consequent upon the absence of greed, hatred and ignorance. Such beings can, by the practice of watchfulness with regard to states both mental and material, so adapt and develop themselves as to be able ultimately to dwell quite apart from such unskilful and regressive conditions.

299. To return now to the original question, viz., in what way are the good roots to be described? Still bearing in mind the frequent practice throughout the Piṭakas of naming the good roots and their associated qualities in terms of the negative values of the bad roots and qualities, it should not be overlooked that the absence of those bad roots and associated qualities in no way implies a mere static condition, a state of general non-activity. Absence of the bad roots means that, in terms of activity as a whole, it is to the bad roots and their associated qualities alone that any such inactivity applies. Consequently, in terms of states accompanied by roots,

¹⁰⁶ See Dialogues of the Buddha, Vol. 1, No. 1, "The Perfect Net."

only those named “beautiful” can be operative. Thus because of non-action of the bad, there is action that is skilful and good.

300. The importance of this distinction is well illustrated in the introductory section to the initial volume of the great first division of the Tipiṭaka, called Vinaya Piṭaka. This Piṭaka is concerned largely with a detailed enunciation of the rules of moral practice, more particularly as they apply to Bhikkhus and Bhikkhunīs. However, in this introductory section entitled Verañjakaṇḍa, it records how a Brahmin approached the Buddha, and in the course of conversation said, “I have heard that the revered Gotama professes a DOCTRINE OF NON-ACTION (*akiriya-vada*);” to which the Buddha replied, “Certainly, Brahmin, there is a reason, a reason whereby one speaking rightly of me could say, the recluse Gotama professes a doctrine of non-action. For, Brahmin, I indeed proclaim non-action in respect of wrong bodily conduct, of wrong vocal conduct and of wrong mental conduct; in respect of the many and varied evil, bad states I proclaim non-action. Certainly, Brahmin, this is a reason, a reason whereby one speaking rightly of me could say, ‘the recluse Gotama professes a doctrine of non-action,’ but certainly not in respect of that which you have averred.¹⁰⁷”

301. In this passage the Buddha made two things very clear. First he declared the types of states concerning which there should be absolute non-activity—in Abhidhamma terms, states accompanied by bad roots—second, by the direct implication of that passage, he in effect made the unspoken declaration of the essentiality of positive action in respect of all the many and varied skilful, good states associated with which there is good bodily conduct, good vocal conduct and good mental conduct; in other words, RIGHT THOUGHT (*samma-saṅkhappa*), RIGHT SPEECH (*samma-vaca*), and RIGHT ACTION (*samma-kammanta*). However, in so doing the Buddha also inferred the entire NOBLE EIGHT CONSTITUENT PATH (*ariya-atthangikamagga*), viz., RIGHT VIEW (*samma-ditṭhi*), RIGHT THOUGHT (*samma-saṅkhappa*), RIGHT SPEECH (*samma-vaca*), RIGHT ACTION (*samma-kammanta*), RIGHT LIVELIHOOD (*samma-ājīva*), RIGHT EFFORT (*samma-vāyāma*), RIGHT MINDFULNESS (*samma-sati*) and RIGHT CONCENTRATION (*samma-samādhi*); for in the application of every one of these eight positive and interdependent constituent elements there is brought to bear the powerful action of the three entirely positive good roots: absence of greed, absence of hatred and absence of dullness and delusion.

302. Even so, these negative sounding titles can often prevent the thorough-going positive nature of the good roots from being properly understood. In English, therefore, that this positive aspect may be stressed, the notion of absence of greed can well be expressed in positive form as generosity; absence of hatred can be expressed as goodwill, loving kindness or amity; and absence of dullness and delusion as wisdom.

303. Thus, in simplified practical terms the roots of all goodness are generosity, goodwill, and wisdom. Provided, therefore, in making use of these names—for they are only names—their application is correctly interpreted in terms of the actual underlying motive at the time of action, and in the absolute ethical sense is seen to be strictly in accordance with absence of greed, absence of hatred and absence of dullness and delusion respectively, they can be said to represent a very sound basis upon which a general understanding of the positive nature of the three good roots may be built up.

304. Despite this positive naming, though, the value of becoming fully conversant with the manner in which the bad roots manifest themselves cannot be too strongly emphasized, for in the Teaching of the Buddha it is the ultimate eradication of roots productive of fault, which is

¹⁰⁷ See also B.D., vol. 1, p. 1 ff; G.S., vol. 4, p. 117 ff.

the real point at issue. The presence of fault means an automatic absence of its skilful counterpart. Awareness of a fault is therefore the first stage towards its eradication. In consequence of this, even a purely theoretical or so-called scholastic awareness of the range and scope of unskilful, bad action constitutes a type of knowledge which can be productive of good. Such knowledge, if applied in the purely practical sense so consistently set forth by the Buddha, is that which promotes the skilful, inhibits the unskilful, and thereby prepares the way for mental development and the attainment of penetrative insight.

305. In connection with the acquiring of such knowledge the Piṭakas abound with suttas wherein the Buddha speaks both in terms of abandoning the unskilful and fostering the skilful. As to abandoning the unskilful, both in terms of action and view, the Brahmajāla Sutta of Dīgha Nikāya¹⁰⁸ is most explicit, as also is the Sammādiṭṭhi Sutta of Majjhima Nikāya,¹⁰⁹ which latter was originally delivered by the Buddha's close and learned disciple Ven. Sāriputta. With regard to the practice of the skilful, particularly from the point of view of the layman, the Sigalovāda Suttanta¹¹⁰ is of special importance. Within the books of the Abhidhammapiṭaka itself one of the most valuable and detailed statements of the extent and ramifications of evil, bad states is the seventeenth chapter of Vibhaṅga, entitled Khuddaka Vibhaṅga. In translation this is called "Analysis of Small Items,"¹¹¹ and here in ten summaries and ten expositions of those summaries, together with an additional exposition on the occurrences of craving, there exists a most extensive synopsis of both the apparent and the subtle ways in which the three bad roots are constantly operative.

306. Referring now to the Commentary Atthasālini.¹¹² The denotations given for "absence of greed" are the General Characteristic of absence of covetous wish in respect of objects, or, a state (or condition) of unattachedness, like a water drop on a lotus petal; the Inherent Functional Property of non-grasping, like a Bhikkhu free (from the rounds of rebirth); and the Resultant Appearance of the state (or intention) of being "apart from," as in the case of a man who has fallen into filth.

307. In the case of "absence of hatred" the General Characteristic is absence of ferocity, or absence of enmity, like an agreeable friend. The Inherent Functional Property is that it drives away vexation, or, it drives away the fever (of passion), like sandalwood (drives away insects); and the Resultant Appearance is, being gentle and pleasing like the full moon.

308. "Absence of dullness and delusion" has the General Characteristic of penetration as to the true nature (of things), unfaltering penetration like the penetration of an arrow shot by a skilled Bowman. The Inherent Functional Property being that of illuminating the object (of sense or ideation) like a lamp; and the Resultant Appearance, absence of confusion like a good forest guide. The detailed explanation of these three good roots as given in this same Commentary is particularly useful in that it presents the many ways in which, as roots, they are responsible for the qualities present in the occurrence of good states.¹¹³

309. With regard to the final denotations of these three, i.e., their Concurrent Footing, no details are given at this point in the Commentary. However, another work, Nettipakaraṇa, furnishes that information. Thus, in the case of "absence of greed" it is the ABSTAINING FROM

¹⁰⁸ D. vol. 1, no. 1 "The Perfect Net."

¹⁰⁹ M.L.S. vol. 1, p. 57, "Discourse on Perfect View."

¹¹⁰ D. vol. 3 p. 173.

¹¹¹ B.O.A., pars. 832-977 inc.

¹¹² See also Exp. pp. 162 & 167; Ppn. p. 525.

¹¹³ Exp. pp. 167-170 inc.

TAKING THAT WHICH IS NOT GIVEN (*adinnādānā-veramanī*), i.e., the second of the Five Precepts. In the case of “absence of hatred” it is the ABSTAINING FROM KILLING BEINGS (*pānātipātā-veramanī*), i.e., the first of the Five Precepts. The Concurrent Footing of “absence of dullness and delusion” is RIGHT KNOWLEDGE AND ITS ASSOCIATED PRACTICE (*sammā-
paṭipatti*). In this way the four denotations of the three good roots are completed.

310. As a point incidental to the details of these Concurrent Footings, some mention should be made of Nettipakaraṇa itself, for although not frequently spoken of it is nevertheless of immense importance to the proper understanding of the Buddha’s Teaching. That it is a work of very early date is undoubtedly true, for it is certainly far more ancient than the Commentaries as they have existed since the fifth and sixth centuries A.D. Traditionally it is ascribed to Ven. Mahākaccāna, one of the Buddha’s contemporaries and most able and learned disciples. Of him the Buddha said, “The most eminent of my Bhikkhu disciples in explaining analytically that which is said in abridged form is Mahākaccāna.”¹¹⁴

311. Nettipakaraṇa explains in detail the way by which the full implication of the Buddha’s Teaching may be determined. Its method consists of the systematic examination of any particular passage in accordance with a strict plan of analysis, together with accurate observance of basic definitions. It is therefore a treatise which forms a GUIDE (*netti*) for commentators, in that from its basic structure it shows how the often abridged and terse language of the Piṭakas may be expanded to disclose its full meaning. Although the exact details of its past history are little known, in Burma it is traditionally included within the Tipiṭaka itself. This inclusion is not the case in Sri Lanka, nevertheless its authority is equally respected. In translation it is entitled, “The Guide.”¹¹⁵

¹¹⁴ A. Ekakanipāta, Sutta 14, part 1; see also K.S. vol. 1, p. 17.

¹¹⁵ P.T.S. Trans., Nānamoli.

ABHIDHAMMATTHASAṄGAHA Talk No. 6 (Part 2)

312.¹¹⁶ The questions now to be examined are, first, which are the BEAUTIFUL integral CONSCIOUS STATED CHARACTERISTIC OF THE PLANE OF SENSE DESIRE (*kāmāvacara-sobhanā-cittāni*); and second, into what categories do they fall?

313. In answer to the second part of this question it can be said that the categories are threefold, viz., (1) GOOD (productive) integral CONSCIOUS STATES (*kusala cittāni*), (2) RESULTANT integral CONSCIOUS STATES HAVING ROOTS (*sahetuka-vipāka-cittāni*) and (3) INOPERATIVE integral CONSCIOUS STATES HAVING ROOTS (*sahetuka-kiriya-cittāni*).

314. Why is it that these three particular categories of “beautiful states” are characterized as Kāmāvacara, that is, as being Characteristic of the Plane of Sense Desire? As mentioned earlier¹¹⁷ they are states which are concerned to a very considerable extent with stimuli impinging upon the five doors of sense, and with the consideration or recollection of such stimuli by way of the mind door. In view of the nature of these stimuli, their origin and their relationship to the integral states that arise because of them, the word Kāmāvacara can be expressed as meaning a condition, state or quality wherein consciousness moves about, with which it is familiar, where it is at home and which it frequents. This is indeed so, for Kāmāvacara, translated literally, means MOVING ABOUT IN (*āvacara*) SENSE DESIRE (*kāma*). This, though, does not explain the matter fully, there being other considerations. Kāma as a specific term has two distinct connotations, for not only does it refer to that which DESIRES (*kāmeti*) but also to that which IS DESIRED (*kāmiyati*) by that very desire. Thus on the one hand it extends only to the basic desire for stimulation of the six bases of sense, whereas on the other hand it points to that from which, or by means of which, such desired stimulation may be realized. Consequently in the first instance the word Kāmāvacara gives the name to those classes of consciousness which as a group are largely associated with sense desire itself, and in the second instance that same word, Kāmāvacara, gives the name to the PLANES (*bhūmi*) wherein the many and varied objects of sense are prevalent.

315. Therefore, when, with reference to integral states, the term Kāmāvacara is used and expressed as Characteristic of The Plane of Sense Desire, it should be understood as comprising all the above meanings, in that it is the classification name for the types of consciousness which in their mundane sense of need for objective stimulus cleave to and move about in those levels, planes or modes of existence which provide such objective stimuli. Thus Kāmāvacara citta is the consciousness characteristic of the Kāmāvacara-bhūmi. Paraphrasing the Commentary¹¹⁸ it may be said that much as a battlefield is so called because it is resorted to by armed men, so “the Plane of Sense Desire” is so called because it is resorted to by consciousness habituated to sense desire. Conversely, in the way in which an elephant because of its particular ability in the field of battle may have earned the title “battle experienced,” so those integral conscious states which arise readily in connection with objects of sense earn thereby the title “consciousness Characteristic of the Plane of Sense Desire”

316. Reverting now to the three categories of “beautiful states” included in this classification. The first of these, “good (productive) integral conscious states,” as their basic name together with the specially added word “productive” suggests, are strong in the sense of ACTION (*kamma*) and are therefore correspondingly productive in terms of resultant. Here, though, it

¹¹⁶ See chart 8.

¹¹⁷ Par. 46.

¹¹⁸ Exp. pp. 82 & 83.

should be observed that although no direct mention of roots has actually been included in their title, the existence of such roots is nevertheless inferred. That this is so is shown by verse 10, where certain of the resultants of these and other good states are seen performing eight functions in respect of the sense operation that can take place in the first phase of the active conscious process (i.e., the eight rootless integral conscious states which are the resultants of good action¹¹⁹). That other important and powerful resultants are also produced is shortly to be discussed.

317. If these good, skilful states are indeed thus productive of resultant, in what position do they operate in a total course of the active conscious process? In this respect their position is absolutely fixed, for their relationship with other states in that process is causally determined by the particular function they perform. In operation their most noteworthy feature, quite apart from being productive of resultant, is their intrinsic full awareness of the conceptualized object as determined by the preceding function. As in the case of the twelve bad, unskilful states, they come to be immediately following, and because of, the cessation of the so-called dual function of DETERMINING or MIND-DOOR-ADVERTING (*votthabbana/mano-dvār āvajjana*). This function, as has been seen, completes the first phase of the active conscious process, no matter whether that process has been dependent for its arising on any of the five material objects of sense, or upon a purely mental object. Thus, in position the good states are similarly placed to the bad, the important difference between them being that whereas the twelve bad states operate solely in association with BAD ROOTS (*akusala-hetu*), the good states arise accompanied always by GOOD ROOTS (*kusala-hetu*).

318. When giving a name to the integral states, both skilful and unskilful, which arise in causal succession to the final function of the first phase of active conscious process, the expression "full awareness" has already been used many times. In continuing so to do its use should nevertheless be looked upon purely in the nature of a compromise, for it cannot be fairly considered as a direct translation of *javana*, the Pāli term it is intended to represent. As has just been shown, "full awareness," from its face value, expresses only that aspect of the whole process which the average person would consider to be its most important. In other words it is, in conventional terms, the only phase within that whole active conscious process upon the arising of which the so-called individual could rightly say, "I know about, I am conscious of, I am fully cognizant of the presence of the object." It is for this reason alone that the expression "full awareness" has been used.

319. The word *javana* itself, when made use of in the purely technical sense of its Abhidhamma application, would seem to defy any comprehensive yet straightforward translation into English. The reason for this is that it combines the ideas of going forward and knowing; then, coupled with these can be included to some extent its more conventional interpretation conveying the notion of rapidity, which rapidity can be applied to the way in which this series of second phase integral states react to the conceptualized object in terms of any particular attitude or opinion held at that time. Thus ACTION (*kamma*) is involved and thereby RESULTANT (*vipāka*).

320. Therefore, when with reference to the second phase of the conscious process the words "full awareness" are used, meaning "a knowing of the object," it is essential to appreciate most fully that of the other aspects implicit in those states such as attitude to the object, FEELING (*vedanā*), ACTION or VOLITION (*kamma, cetanā*), RESULTANT (*vipāka*) and the many other

¹¹⁹ See par. 207.

concomitant factors, all are equally strongly present and act together with this full awareness as parts of an operative whole. To this extent “full awareness” then represents *javana*.

321.¹²⁰ To turn now to the first part of the original question: what are the beautiful integral conscious states characteristic of the Plane of Sense Desire? At first sight the general arrangement of each of the three classes of states included therein would seem to be strongly reminiscent of that of the greedy states enumerated in verse 4. Both comprise groups of eight individual states, both show similar divisions into pleasant mental feeling and neutral feeling, and both have comparable sub-divisions into instigated and uninstigated. This, though, is a purely superficial appearance, and useful only as an aid to memory, for in practice good states differ widely from greedy states, both in broad terms and as is shown in the much deeper analysis afforded by chapter 2 of *Abhidhammatthasaṅgaha*.

322. Verse 15 enumerates the good (productive) integral states. These constitute the primary group of skilful states that operate most characteristically in those planes of existence where the objective qualities most sought after by desire are to be experienced most readily.

VERSE 15

| | |
|-----------------------------------------------|----------------|
| SOMANASSA-SAHAGATAM ÑĀNA-SAMPAYUTTAM | |
| ASANKHĀRIKAM EKAM SASANKHĀRIKAM EKAM | (States 1 & 2) |
| SOMANASSA-SAHAGATAM ÑĀNA-VIPPAYUTTAM | |
| ASANKHĀRIKAM EKAM SASANKHĀRIKAM EKAM | (States 3 & 4) |
| UPEKKHĀ-SAHAGATAM ÑĀNA-SAMPAYUTTAM | |
| ASANKHĀRIKAM EKAM SASANKHĀRIKAM EKAM | (States 5 & 6) |
| UPEKKHĀ-SAHAGATAM ÑĀNA-VIPPAYUTTAM | |
| ASANKHĀRIKAM EKAM SASANKHĀRIKAM EKAM TI | (States 7 & 8) |
| IMANI ATTHA PI KĀMĀVACARA-KUSALA-CITTĀNI NĀMA | |

Meaning:

There are two good (productive) integral states wherein factorial consciousness is:

ACCOMPANIED BY MENTAL PLEASURE (*somanassa-sahagata*) and ASSOCIATED WITH KNOWLEDGE (*nāna-sampayutta*) of which ONE (*eka*) is UNINSTIGATED (*asaṅkhārika*) and ONE (*eka*) INSTIGATED (*sasaṅkhārika*).

There are also two ACCOMPANIED BY MENTAL PLEASURE (*somanassa-sahagata*) but DISSOCIATED FROM KNOWLEDGE (*nāna-vippayutta*) of which ONE (*eka*) is UNINSTIGATED (*asaṅkhārika*) and ONE (*eka*) INSTIGATED (*sasaṅkhārika*).

Then a further two ACCOMPANIED BY NEUTRAL (*upekkhā-sahagata*) feeling and ASSOCIATED WITH KNOWLEDGE (*nāna-sampayutta*) of which ONE (*eka*) is UNINSTIGATED (*asaṅkhārika*) and ONE (*eka*) INSTIGATED (*sasaṅkhārika*).

Finally there are two ACCOMPANIED BY NEUTRAL (*upekkhā-sahagata*) feeling but DISSOCIATED FROM KNOWLEDGE (*nāna-vippayutta*) of which ONE (*eka*) is UNINSTIGATED (*asaṅkhārika*) and ONE (*eka*) INSTIGATED (*sasaṅkhārika*).

THESE (*imāni*) EIGHT TOGETHER (*attha pi*) ARE KNOWN AS (*nāma*) GOOD (*kusala*) integral CONSCIOUS STATES (*cittāni*) CHARACTERISTIC OF THE PLANE OF SENSE DESIRE (*kāmāvacara*).

323.¹²¹ The qualities of the three good roots, which in suitable combination accompany these eight integral states, have already been described¹²² as also have the two types of feeling,¹²³ and

¹²⁰ See chart 9.

¹²¹ See chart 9.

the presence or absence of instigation;¹²⁴ though in this latter case certain differences will later be shown to exist. Consequently the very particular quality which remains to be discussed, both as to its own attributes and its effect on states in which it is, or is not, incorporated, is KNOWLEDGE (*nāna*).

324. When the meaning of VIEW (*ditṭhi*) was elaborated,¹²⁵ it was shown to include any belief or hypothesis not in accord with ultimate truth. Knowledge, on the other hand, as it is applied in Abhidhamma studies, embraces neither belief nor hypothesis but only that which is strictly in accord with ultimate truth.

325. The Pāli word *nāna*, knowledge, has many synonyms, one of which is *paññā* with which it is often interchanged; much in the same way as in English, wisdom, comprehension, understanding, etc., are interchanged with knowledge according to the context; thus its range of application is very wide. However, the Commentary Atthasālini,¹²⁶ referring to this equivalent, *paññā*, is most explicit as to its meaning, it says:

“*Paññā* means one knows (or comprehends). What does one know? ‘This is suffering,’ etc., according to the procedure of the (4) Noble Truths. In the (Great) Commentary,¹²⁷ however, it was said, ‘*Paññā* means, it causes one to know.’ What does it cause one to know? It causes one to know (comprehend) ‘Impermanence, Suffering and Absence of Soul.’ Illumination is the characteristic of *paññā* as knowledge is also its characteristic. Indeed, just as in a four walled house at night time wherein is a lighted lamp, darkness ceases (and) light becomes manifest, even so, illumination is the characteristic of knowledge. There is indeed no light equal to the light of knowledge.”

326. Referring now to *Visuddhimagga*¹²⁸ it says concerning *paññā*: “Its General Characteristic is penetrative comprehension of the inherent nature (of states). Its Inherent Functional Property is the obstruction of dullness and delusion concealing the inherent nature of states. Its Resultant Appearance is absence of dullness and delusion.” Because of the statement¹²⁹ “... he who is concentrated knows and sees in accordance with absolute reality, concentration is its Concurrent Footing.”

327. The arrangement of good (productive) states in verse 15 is very clear, in that four of its eight sections are seen to be ASSOCIATED WITH KNOWLEDGE (*nāna-sampayutta*), and four DISSOCIATED FROM KNOWLEDGE (*nāna-vippayutta*). Since, as has been shown, all the three good roots, i.e., generosity, goodwill, and knowledge, are fundamentally important associates of skilful conscious states, it is evident that although in the above classification only the presence or absence of knowledge is mentioned, the other two roots must in some way be playing their part. Because of this being so it is correct to say of “beautiful integral conscious states having roots,”

¹²² See par. 299 ff.

¹²³ See par. 77 ff.

¹²⁴ See pars. 94-95.

¹²⁵ See par. 82 ff.

¹²⁶ See Exp. p. 161.

¹²⁷ This refers to one of the ancient commentaries brought from India to Ceylon by Ven. Mahinda circa 240 B.C. For the convenience of the islanders it was translated by him into the then current form of Sinhalese. In the course of the recompilation and translation of these ancient commentaries from this old form of Sinhalese into Pali during the fifth century A.D., Ven. Buddhaghosa incorporated the subject matter of the Great Commentary (*Mahāṭṭhakathā*) together with that of the other commentaries, both Indian and Sinhalese.

¹²⁸ See also Ppn. p. 481.

¹²⁹ See also G.S. p. 4.

that, quite irrespective of the particular group amongst the many groups to which individual integral states may belong, all are invariably associated with the two roots, generosity and goodwill (i.e., absence of greed and absence of hatred: *alobha*, *adosa*). Moreover, it can be further said that it is only in connection with good (productive), resultant and inoperative integral conscious states Characteristic of the Plane of Sense Desire that any dissociation from knowledge occurs.

328.¹³⁰ From this it can be deduced that “beautiful integral states” classified as DISSOCIATED FROM KNOWLEDGE (*nāna-vippayutta*) are thereby associated with the two good roots only, generosity and goodwill; whereas all others have the three good roots: generosity, goodwill and knowledge.

329. Putting on one side for the moment any consideration of the type of feeling present, and whether a conscious state has arisen in a completely voluntary manner or has been instigated, the question now occurs: what is the difference in practice and outcome between thought, speech and action associated with two good roots, or alternatively with the three good roots?

330. In the first instance, if a person performs or encourages others to perform kind, helpful actions, if he speaks in a gentle heartening way or even only thinks thoughts similarly directed, yet at the same time gives no consideration to the deeper significance of such actions apart from their bare rightness, this either because of their spontaneity, their habituality or as being thought of as the ordinary and proper course for a right thinking person to pursue; such actions are two rooted. Why is this so? Because whether done on the spur of the moment, whether based on excellent custom or on a sound conviction of rightness, the root structure is without any real penetration in respect of the true nature of the action. As action, though, it is nevertheless highly moral and truly progressive in that same moral sense, quite irrespective of the source of that morality as the expression of a particular moral code. Being action, it is productive of resultant; which resultant, being as it were habit forming in the best sense, creates the tendency for further comparable activity.

331. Thus, skilful action based on practical application of the positive aspect of ABSENCE OF GREED (*alobha*) and of ABSENCE OF HATRED (*adosa*), forms, builds up, strengthens and consolidates the first element of the three great fundamentals of training, MORAL PRACTICE (*sīla*), MENTAL DEVELOPMENT (*bhāvanā*), and WISDOM (*paññā*). Of itself moral practice cannot create the other two; without it, though, the other two cannot come to be, increase, and attain to the full growth that culminates in the CESSATION OF SUFFERING (*dukkha-nirodha*).

332. Three rooted skilful integral states Characteristic of the Plane of Sense Desire differ from the class just discussed in one major particular, the presence of the root of absence of ignorance, or, in its positive sense, knowledge. Here it should be emphasized that the meaning of the word “knowledge” is to be understood as already stated;¹³¹ thus it should not be interpreted as that which is a summation of relative data concerning the world and worldly activity as a whole; on the contrary, it constitutes a recognition of principles which are ultimate and which are quite detached from the way in which the phenomenal world is ordinarily interpreted and grasped at, “... firmly as truth.”¹³² Here, it is that which shows not only the universal nature of the reaction which takes place between awareness of mundane phenomena and the twin forces of ignorance and craving, but also the principle by which such reaction is brought to cessation. Thus,

¹³⁰ See chart 9.

¹³¹ See par. 324 ff.

¹³² B. of A. par. 948.

although the word “knowledge” is frequently used, its connotation in this instance is “understanding” or “wisdom.”

333. Bearing this in mind the four integral states having three roots, and which fall into the category now being discussed, are seen to be associated not only with generosity and goodwill, but with knowledge also. Dependent upon the extent and depth of this knowledge, such states are thus imbued with an innate recognition of the ultimate truth of the omnipresence of IMPERMANENCE (*anicca*), SUFFERING (*dukkha*) and ABSENCE OF SOUL (*anattā*), of the ultimate truth that CRAVING (*tanhā*) is the CAUSE OF SUFFERING (*dukkha-samudaya*) and that the CESSATION OF SUFFERING (*dukkha-nirodha*) comes about only by the proper understanding and practice of the NOBLE EIGHT CONSTITUENT PATH (*ariya-ajjhāngika-magga*, viz., right view, right thought, right speech, right action, right livelihood, right effort, right mindfulness and right concentration). Coupled with these three knowledges there is the further recognition that throughout the whole continuity of process called existence there is a direct causal relationship between adjacent states, forming a self-perpetuating series which persists unflinchingly while ignorance and craving remain in any degree operative.

334. From this it can be appreciated that when a person says, “I know what I am doing,” the condition of knowing referred to rarely has any connection with the definition of knowledge intended regarding three rooted integral states. Knowledge in that specific sense does not occur frequently. In the usual course of events it is reasonable to say that when people act in a skilful manner, either by way of thought, speech, or bodily action, that skill represents a strengthening of moral tendency by way of absence of greed and absence of hatred only. Where, however, there is present in such states even a glimmer of understanding of the kind specified, the action associated therewith strengthens not only the background of MORAL PRACTICE (*sīla*), but, because of the participation of the root of absence of dullness and delusion, the background of UNDERSTANDING (*paññā*) also. Moreover, where there exists conscious effort directed towards the analysis of problems concerned with the gaining of such understanding, not only is the arising of knowledge stimulated but there is MENTAL DEVELOPMENT (*bhāvanā*) as well.

335. The breadth and depth of knowledge that can be associated with good (productive) states Characteristic of the Plane of Sense Desire should never be minimized or underestimated, for although at its lowest point it may be but a mere glimmer when related to ultimate understanding, that glimmer can nevertheless, with intention and hard practice, be increased to encompass such profound insight as is implicit in the full development of the FOUR ANALYTIC INSIGHTS (*catasso patisambhidā*). Although these insights are still “of the world,” they form a final frontier of the mundane, beyond which there arises the true PENETRATIVE INSIGHT (*vipassanā*), which is supramundane; that is, the insight which sees things as they are in ultimate reality, and which, in its final phases of utter and final release from suffering, brings about conditions which render both itself and succeeding states incapable of being in any way productive of further resultant tending towards rebirth.

336. Consequently, where the three good roots operate together, the three basic requisites for complete and balanced progress, viz., MORAL PRACTICE (*sīla*), MENTAL DEVELOPMENT (*bhāvanā*) and WISDOM (*paññā*), are also being built up and consolidated.

337. It has been said earlier that bad (productive) integral states, because of their association with IGNORANCE (*avijjā*) and CRAVING (*tanhā*), represent, by way of the three bad roots, ACTIVITY CUMULATIVE OF RESULTANT TENDING TOWARDS REBIRTH.¹³³ It has also just been mentioned that the final phases of supramundane penetrative insight institute conditions

¹³³ *Bhava*; see par. 121.

entirely eliminating any further production and accumulation of such resultant tendency; can it therefore be said that all good (productive) integral states intermediate between these two groups are themselves productive of resultant tending towards rebirth? The simple answer to this question is most certainly yes. Because of this a new question now presents itself: if, as has been seen, the tendency to rebirth depends ultimately upon actions rooted in ignorance, why is it that good states—being themselves associated with the good roots—are thus productive of rebirth tendency?

338. Generally speaking it is customary to use ROOTS (*hetu*) as the basis for grouping and classifying integral states. It is a straightforward method and differentiates the states very clearly, nevertheless it is not the only basis upon which classification may be made. Although, by way of root classification, ignorance, in the form of dullness and delusion, appears to be quite cut off by good roots, there are many other ways, far more subtle, by which this insidious quality maintains its strong hold on mundane states. When considering existence as a continuity of process, that process as a whole is referred to as *saṃsāra*, meaning literally moving on, circulation. For this reason it is often represented figuratively as a wheel to which beings are fettered until such time as the fetters are broken and dispersed by the power of penetrative insight. These so-called fetters are just one of the ways by which the activity of ignorance and craving become manifest independently of simple root structures, and under that title are included in the *mātikā* of *Dhammasaṅgani* as a basis upon which states may be classified.

339. The TEN FETTERS (*dasa saṃyojanāni*) as manifestations of ignorance and craving are operative not only in a direct manner, as in the bad integral states, but also throughout mundane states generally. Because worldly states do not see things as they are in absolute reality, the six objects are to that extent viewed in a manner akin to ignorance. Good states, therefore, although they do not arise based on ignorance in the form of dullness and delusion, nevertheless, because of their absence of penetration, are favourable to the maintenance and growth of the fetters. In as much as good states are vitiated by ignorance and its associated fetters, they can be regarded as objects of those fetters. Moreover, because of their relative closeness to ignorance, when compared with the penetrative insight of ultimate understanding that breaks down and utterly uproots that ignorance, they are low, and are thus fettered to the round of rebirth. Because of this they represent ACTIVITY CUMULATIVE OF RESULTANT TENDING TOWARDS REBIRTH (*bhava*). Good states, although they inhibit the root of DULLNESS AND DELUSION (*moha*), together with the other bad roots, do not thereby eradicate IGNORANCE (*avijjā*).

ABHIDHAMMATHASANGAHA Talk No. 7 (Part 1)

340. If in connection with existence as a whole one recognizes therein the basic principle of its being a continuity of process, then from what has been said so far of productive states, good and bad, together with the resultants that arise because of them, there emerges a truly frightening picture. Admittedly this is in part accounted for by the fact that the enumeration of integral states has by no means yet been completed, nor have the implications of their various groupings been explained; even so, when such has been done the reasoned knowledge arising from Abhidhamma study still shows that frightening picture as a very potent reality. Moreover, this is especially so wherever there is failure to exert any real pressure in the direction of strengthening the three basic aspects of progress, viz., moral practice, mental development and wisdom.

341. But why is the picture still so frightening? Basically because it would appear to show the so-called being as nothing other than a trapped cyclic process dependent upon integral states producing rootless resultants; resultants which, in their turn, virtually dominate the first phase of further active conscious process, thereby preparing the way for integral states of the second phase destined to produce more rootless resultants, and so on, in a never ending, self-perpetuating cyclic series. The frightening aspect of this is its apparent inevitability, for, up to a point, such an interpretation of the state of affairs is indeed strictly true. A very important feature to bear in mind, illustrating the possibility of such a course taking place, is apparent inasmuch as that, on no occasion did the Buddha teach a doctrine of automatic and inevitable forward progress towards the ultimate goal, Nibbāna, without there being, at the same time, a step by step applied effort directed specifically towards that ultimate goal. By implication, therefore, if no effort is made, the inevitability of such a cyclic series becomes clearly evident,

342. This is not the juncture at which to speak of the phases of death and rebirth, which occur serially as normal functions within that continuity of process called existence. It is a complex subject, particularly in respect of the many states, mental and material, which are capable of performing important functions in its occurrence; for this reason, therefore, it is dealt with in considerable detail in later chapters of Abhidhammatthasaṅgaha. However, in connection with the self-perpetuating aspect of the cyclic series, it is sufficient to say that of the many resultant states that can determine and are indicative of the class of rebirth that is to take place immediately following death, there are, among the rootless resultants of both good and bad action, particular states (i.e., *santirana-citta*) which besides fulfilling their more frequent functions in the first phase of the conscious process do also, on specific occasions, perform certain of the special functions occurring at the time of death and rebirth. Unfortunately, though, the conditions which their operation presupposes are not at all conducive to forward progress. Forward progress is by no means an easy course either to follow or achieve, consequently the prospect open to those who do nothing directly towards such progress is, when viewed in terms of this self-perpetuating cyclic series, a truly frightening picture.

343. Such would be the inevitable state of affairs if rootless resultants were the only kind that could occur, for, as has already been shown, in the case of bad states the only direct resultants possible are indeed the seven rootless states enumerated in verse 9. From this the clear inference to be drawn is that where there is a reduction in the practice of the eight greedy, the two hateful and the two dull and deluded (productive) integral states, to that extent there is a reduction in the coming to be of their corresponding resultants. In this way less fuel is added to the twin fires of ignorance and craving, with a consequent weakening of the tendency to inevitable self-perpetuation of the cyclic series. It is in just such a connection that the Buddha, while

summarizing the teaching of all Buddhas,¹³⁴ proclaimed the importance of, "THE NOT DOING OF ANY EVIL (*sabba pāpassa akaraṇam*)"

344. Fortunately the inevitability of the cyclic series is not absolute. If it were so all would be hopeless. There is a way, a way which has likewise been proclaimed by the Buddha in the continuation of that same verse of Dhammapada, where it says, "THE UNDERTAKING OF THE SKILFUL, THE PURIFICATION OF ONE'S OWN MIND (*kusalassa upasampada, sacitta pariyodapanam*)." Here, reference is being made to the practice of appropriate skilful states, examples of which comprise beautiful (productive) states as given in verse 15 of Abhidhammatthasaṅgaha, wherein the purification of one's own mind is represented by the putting on one side of views and hypotheses by the acquisition of true knowledge, i.e., understanding and wisdom.

345. These beautiful (productive) states, although themselves giving rise to the eight rootless resultants listed in verse 10 of Abhidhammatthasaṅgaha, also originate a series of far more powerful RESULTANTS HAVING ROOTS (*saḥetuka vipāka*). Moreover, when in appropriate, auspicious circumstances connected with death and rebirth, resultants of this kind, having roots, come into play performing the same function earlier attributed to certain rootless resultants, i.e., the function called CONSTITUENT POTENTIALITY OF BEING.¹³⁵ The nature of rebirth based on such good roots, when compared with rootlessness, far from being non-conducive to forward progress is, on the contrary, in every way of the greatest assistance. Furthermore, where at the time of rebirth the root combination is suitable, it can even be potential to the final attainment of release from any future rounds of rebirth;

346. As an example, if a being is born whereof the function of bhavaṅga (which comprises the non-active instants of resultant consciousness maintaining the continuity of sentient existence¹³⁶) is performed by a resultant integral state having the three roots of absence of greed, absence of hatred and absence of dullness and delusion, the potentiality of that being in respect of realization of the CESSATION OF SUFFERING (*dukkha-nirodha*), Nibbāna, is very high indeed. This is an interesting point, and one not often stressed in connection with thin CONSTITUENT POTENTIALITY OF BEING (*bhavaṅga*). As a further example, if a being is born based on a ROOTLESS (*ahetuka*) resultant its capacity and ability for forward progress is extremely limited. If a being is born based on a "beautiful" resultant that is TWO-ROOTED (*duhetuka*) its capacity and ability in moral practice and mundane understanding may well reach to very great heights; however, because the root of knowledge is not present, such understanding cannot attain to true penetrative insight. Consequently, as it is only the being whose birth is based on a resultant having THREE good ROOTS (*tīhetuka*) that can indeed make an end to suffering, every effort needs to be made to stimulate the right conditions for such an auspicious rebirth to arise.

347. At first sight these purely technical details concerning the relative ability of differently constituted beings to attain penetrative insight may not seem to give particularly strong encouragement to individuals wishing to make progress. However, no such unhelpful attitude should be entertained, even for a single moment, because the actual potentiality of an individual's own underlying root structure cannot be assessed by himself other than on the basis of any actual positive outcome of his own endeavours towards progress. When and how such progress has actually been achieved in the practice of MENTAL DEVELOPMENT (*bhāvanā*) and the attaining of PENETRATIVE INSIGHT (*vipassanā*), is, for the ordinary individual, the one

¹³⁴ See Dhṛ. v. 183.

¹³⁵ Bhavaṅga, see pars. 240/241.

¹³⁶ See par. 240.

clue by means of which in retrospect the nature of the bhavaṅga root structure can be assessed. Consequently, to one who makes it his business to practise, the root structure of bhavaṅga is nothing more than a point of academic interest, and on his part, is not a factor which needs in any way to be determined in connection with that practice. So far as the individual is concerned, effort is the really important criterion in the process of enlightenment practice.

348.¹³⁷ The resultants of the eight beautiful (productive) integral states Characteristic of the Plane of Sense Desire are commonly referred to as the GREAT RESULTANTS (*mahā-vipāka*). They are enumerated in Abhidhammatthasaṅgaha, verse no. 16, and in that enumeration their outward form presents no variation from the productive states of verse 15, it is only in the summary lines that their difference of function is indicated. Structurally, there are some variations from the productive states, but these are small and are specified in Chapter 2 of Abhidhammatthasaṅgaha. As resultants they perform several functions besides that of bhavaṅga mentioned above; these are enumerated in Chapter 3.

VERSE 16

| | |
|--------------------------------------------------------|----------------|
| SOMANASSA-SAHAGATAM NĀNA-SAMPAYUTTAM | |
| ASANKHĀRIKAM EKAM SASANKHĀRIKAM EKAM | (States 1 & 2) |
| SOMANASSA-SAHAGATAM NĀNA-VIPPAYUTTAM | |
| ASANKHĀRIKAM EKAM SASANKHĀRIKAM EKAM | (States 3 & 4) |
| UPEKKHĀ-SAHAGATAM NĀNA-SAMPAYUTTAM | |
| ASANKHĀRIKAM EKAM SASANKHĀRIKAM EKAM | (States 5 & 6) |
| UPEKKHĀ-SAHAGATAM NĀNA-VIPPAYUTTAM | |
| ASANKHĀRIKAM EKAM SASANKHĀRIKAM EKAM TI | (States 7 & 8) |
| IMANI ATTHA PI SAHETUKA-KĀMĀVACARA-VIPĀKA-CITTĀNI NĀMA | |

Meaning:

As the outcome of good (productive) action there are two resultant integral states wherein factorial consciousness is: ACCOMPANIED BY MENTAL PLEASURE (*somanassa-sahagata*) and ASSOCIATED WITH KNOWLEDGE (*nāna-sampayutta*) of which ONE (*eka*) is UNINSTIGATED (*asaṅkharika*) and ONE (*eka*) INSTIGATED (*sasaṅkharika*).

There are also two ACCOMPANIED BY MENTAL PLEASURE (*somanassa-sahagata*) but DISSOCIATED FROM KNOWLEDGE (*nāna-vippayutta*) of which ONE (*eka*) is UNINSTIGATED (*asaṅkharika*) and ONE (*eka*) INSTIGATED (*sasaṅkharika*).

Then a further two ACCOMPANIED BY NEUTRAL (*upekkhā-sahagata*) feeling and ASSOCIATED WITH KNOWLEDGE (*nāna-sampayutta*) of which ONE (*eka*) is UNINSTIGATED (*asaṅkharika*) and ONE (*eka*) INSTIGATED (*sasaṅkharika*).

Finally there are two ACCOMPANIED BY NEUTRAL (*upekkhā-sahagata*) feeling but DISSOCIATED FROM KNOWLEDGE (*nāna-vippayutta*) of which ONE (*eka*) is UNINSTIGATED (*asaṅkharika*) and ONE (*eka*) INSTIGATED (*sasaṅkharika*).

THESE (*imāni*) EIGHT TOGETHER (*attha pi*) ARE KNOWN AS (*nāma*) RESULTANT (*vipāka*) integral CONSCIOUS STATES (*cittāni*) that HAVE ROOTS (*sahetuka*) and are CHARACTERISTIC OF THE PLANE OF SENSE DESIRE (*kāmāvacara*).

349. At an earlier stage the question arose as to the possibility of there being a category of integral conscious STATES NEITHER RESULTANT NOR PRODUCTIVE OF RESULTANT (*neva-vipāka-na-vipāka-dhamma-dhammā*). This was largely in connection with the three rootless

¹³⁷ See charts 8 & 9.

inoperative states enumerated in Abhidhammatthasaṅgaha, verse 11.¹³⁸ However, it was mentioned at the same time that, "... there exists a further series of groupings comprising certain other unique types of integral consciousness such as are experienced only by those who in this life have become free from causal bondage, and have thereby achieved full realization of Nibbāna.¹³⁹" In saying, "... have become free from causal bondage" the implied meaning is that for such beings the task of penetrating to a complete understanding of the nature of reality has been fully accomplished, and because of that accomplishment the TEN FETTERS (*dasa saṃyojanāni*), previously linking them to the cyclic series of repeated, rebirth, are completely destroyed. Thus, for them, there can be no future birth whatsoever in any plane of existence.

350. From what has so far been said of existence, ACTION (*kamma*) produces RESULTANT (*vipāka*); which resultant, speaking in broad terms only, constitutes the very potentiality for future existence and rebirth. Comparing the first statement with this latter, a fresh dilemma appears. In the first statement it is apparent that by virtue of attainment, further production of the non-active instants of resultant, consciousness maintaining the continuity of sentient existence must thereupon cease. Apart, then, from the actual moments wherein consciousness, arising at the so-called mind-door of such a being, experiences Nibbāna as its object, the question is: what categories of conscious states arise to the arahanta during the course of his remaining life in the world of everyday existence?

351. To answer this question the difference between the WORLDLY PERSON (*puthujjana*) and the arahanta needs to be understood in terms of their respective relationships to roots and fetters. The ten fetters, which in connection with the four stages—or paths of attainment—will be discussed later in greater detail, represent basically, active aspects of IGNORANCE (*avijjā*) and CRAVING (*taṇhā*). Moreover, inasmuch as these two pervade the whole of mundane existence, whether referred to in terms of root, fetter, or in any of their many other manifestations, they represent aspects of activity which are deep, harmful and tenacious. The nature of their activity in respect of the cyclic series of paṭiccasamuppāda has already been discussed to a limited extent in connection with bad roots and bad (productive) integral states.¹⁴⁰ It has also been shown in terms of the pervasive qualities of the ten fetters, here again in respect of the same cyclic series, paṭiccasamuppāda, but now in connection with good (productive) integral states. It is therefore abundantly clear that in whatsoever form ignorance, and thereby craving, becomes manifest, the same general pattern of outcome persists, i.e., ACTION CUMULATIVE OF RESULTANT TENDING TOWARDS REBIRTH (*kamma-bhava + upāpatti-bhava*). Such is the product of action as it applies to the ordinary unenlightened worldly person, the puthujjana. It is for this reason that the word "productive" has been used to qualify the nature of integral states, good or bad, which, as thoughts, create and dominate the speech and bodily activity of the worldly person.

352. The position of the arahanta is, however, very different, for in the process of attaining to that final stage the three bad roots have been eradicated, the ten fetters destroyed, and ignorance itself absolutely and irrevocably annihilated. Clearly this is a state without parallel, and as such is one which presupposes a mode of behaviour considerably at variance with that of the worldly person. Thus it is that the arahanta is incapable of performing any bad, unskilful action whatsoever, be it of thought, speech or bodily action; neither can the whole wide range of good, skilful action which he performs based on the three good roots of ABSENCE OF GREED (*alobha*),

¹³⁸ See pars. 232-236 inc.

¹³⁹ See par. 233.

¹⁴⁰ See pars. 108-122 inc.

ABSENCE OF HATRED (*adosa*) and ABSENCE OF DULLNESS AND DELUSION (*amoha*), be causative of any reflexive resultant whatsoever. Thus there is no tendency towards rebirth.

353. From this it is apparent that in his everyday activities in respect of commonplace objects and considerations there cannot arise to the arahanta any “productive” integral states, because in this context “productive” means productive of resultant. Consequently, apart from the rootless resultant and inoperative states which arise performing their appropriate functions as serial instants of the first phase of active conscious process, the second phase integral states of the arahanta in respect of thought, speech and bodily action, although associated with good roots, are nevertheless “neither resultant nor productive of resultant.” For this reason they are classified as INOPERATIVE integral CONSCIOUSNESS HAVING ROOTS (*sahetuka-kiriya-citta*). In this way, therefore, it can be appreciated that whereas the worldly person creates, quite automatically, his own rebirth tendency by means of productive states, good and bad, the arahanta—for whom any such rebirth tendency has ceased to be—acts by way of inoperative states alone.

354.¹⁴¹ It will be observed that the states enumerated in Abhidhammatthasaṅgaha verse 17, although applicable only to the arahanta, are nevertheless still classified as Characteristic of the Plane of Sense Desire. The reason for this is that as individual states they arise in accordance with the same range of objective stimuli as the productive states of verse 15; however, as they belong to the province of the arahanta alone, sense desire in this case refers only to the plane of existence of which they may be said to be generally characteristic, and not to there being any aspect of sense desire associated with the actual arising of those states.

VERSE 17

| | |
|-------------------------------------------------------------------------------|----------------|
| SOMANASSA-SAHAGATAM NĀNA-SAMPAYUTTAM ASANKHĀRIKAM EKAM SASANKHĀRIKAM EKAM | (States 1 & 2) |
| SOMANASSA-SAHAGATAM NĀNA-VIPPAYUTTAM ASANKHĀRIKAM EKAM SASANKHĀRIKAM EKAM | (States 3 & 4) |
| UPEKKHĀ-SAHAGATAM NĀNA-SAMPAYUTTAM ASANKHĀRIKAM EKAM SASANKHĀRIKAM EKAM | (States 5 & 6) |
| UPEKKHĀ-SAHAGATAM NĀNA-VIPPAYUTTAM ASANKHĀRIKAM EKAM SASANKHĀRIKAM EKAM TI | (States 7 & 8) |
| IMĀNI ATTHA PI SAHETUKA-KĀMĀVACĀRA-KIRIYA-CITTĀNI NĀMA | |

Meaning:

There are two inoperative integral states wherein factorial consciousness is: ACCOMPANIED BY MENTAL PLEASURE (*somanassa-sahagata*) and ASSOCIATED WITH KNOWLEDGE (*nāna-sampayutta*) of which ONE (*eka*) is UNINSTIGATED (*asaṅkharika*) and ONE (*eka*) INSTIGATED (*sasaṅkharika*).

There are also two ACCOMPANIED BY MENTAL PLEASURE (*somanassa-sahagata*) but DISSOCIATED FROM KNOWLEDGE (*nāna-vippayutta*) of which ONE (*eka*) is UNINSTIGATED (*asaṅkharika*) and ONE (*eka*) INSTIGATED (*sasaṅkharika*).

Then a further two ACCOMPANIED BY NEUTRAL (*upekkhā-sahagata*) feeling and ASSOCIATED WITH KNOWLEDGE (*nāna-sampayutta*) of which ONE (*eka*) is UNINSTIGATED (*asaṅkharika*) and ONE (*eka*) INSTIGATED (*sasaṅkharika*).

¹⁴¹ See charts 8 & 9.

Finally there are two ACCOMPANIED BY NEUTRAL (*upekkhā-sahagata*) feeling but DISSOCIATED FROM KNOWLEDGE (*nana-vippayutta*) of which ONE (*eka*) is UNINSTIGATED (*asañkharika*) and ONE (*eka*) INSTIGATED (*sasañkharika*).

THESE (*imāni*) EIGHT TOGETHER (*atthapi*) ARE KNOWN AS (*nāma*) INOPERATIVE (*kiriya*) integral CONSCIOUS STATES (*cittāni*) that HAVE ROOTS (*sahetuka*) and are CHARACTERISTIC OF THE PLANE OF SENSE DESIRE (*kāmāvacara*).

355. Verse 17 of Abhidhammatthasaṅgaha, being the final enumeration of states classified under the general heading of BEAUTIFUL integral CONSCIOUSNESS CHARACTERISTIC OF THE PLANE OF SENSE DESIRE (*kāmāvacara-sobhanā-citta*), there follows in verse 18 a summarization of the three groups of eight states included therein.

VERSE 18

ICCEVAM SABBATHĀ PI CATU-VĪSATI SAHETUKA-KAMAVACARA-KUSALA-VIPĀKA-KIRIYA-CITTĀNI SAMATTANI

Meaning:

THUS (*iccevam*) FROM EVERY ASPECT (*sabbathā pi*) the TWENTY-FOUR (*catu-vīsati*) GOOD (*kusala*), RESULTANT (*vipāka*) and INOPERATIVE (*kiriya*) integral CONSCIOUS STATES (*cittāni*) that HAVE ROOTS (*sahetuka*) and are CHARACTERISTIC OF THE PLANE OF SENSE DESIRE (*kāmāvacara*) are FULLY COMPLETED (*samattāni*).

356. In order that there may be a rapid means of calling to mind this same grouping of *kāmāvacara-sobhanā* states, the summary lines just given are followed by a short mnemonic stanza. This stanza states concisely the number, types and the mode of classification adopted, not only in Abhidhammatthasaṅgaha itself but also as it occurs in the canonical source from which the states were drawn, i.e., the first book of the Abhidhammapiṭaka, Dhammasaṅgani.¹⁴²

VERSE 19

VEDANĀ-NANA-SANKHĀRA-
BHEDENA CATUVĪSATI
SAHETU KĀMĀVACARA-
PUNNA-PAKA-KRIYA MATA

Meaning:

BY WAY OF DIVISION into (*bhedena*) FEELING (*vedanā*), KNOWLEDGE (*nāna*) and INSTIGATION (*sañkhāra*), TWENTY-FOUR (*catu vīsati*) integral states ARE KNOWN (*matā*) that HAVE good ROOTS (*sahetuka*), are CHARACTERISTIC OF THE PLANE OF SENSE DESIRE (*kāmāvacara*), are MERITORIOUS (*punna*), RESULTANT (*pāka*) or INOPERATIVE (*kriyā*).

357. With the enumeration of the three categories of “beautiful” states in Abhidhammatthasaṅgaha verses 15, 16 and 17, the entire series of integral states eligible for inclusion within the classification entitled Characteristic of the Plane of Sense Desire is fully completed. It would, therefore, be useful to review these states as a whole, and consider them as they occur in the textual order.

358. The overall plan in respect of *kāmāvacara* states separates them initially into three main categories:

1. Bad States.
2. Rootless States.

¹⁴² See B.P.E. pars. 1–159.

3. Beautiful States.

Then, according to the manner in which they operate within a given main category, the various states fall into one or other of three further categories:

4. Resultant Producing States.
5. Resultant States.
6. Inoperative States.

359. In considering the first main category comprising bad states, because of their activity in terms of thought, speech, and bodily action these states are by definition resultant producing, of which: Eight are rooted in greed together with dullness and delusion. Two are rooted in hatred together with dullness and delusion. Two are rooted in dullness and delusion alone. In all, therefore, there are twelve bad (productive) integral states.

360. The second main category comprises rootless states, some of which are the outcome of bad action, some of good action, whereas others are inoperative. Of these: Seven are the rootless resultants of bad action. Eight are the rootless resultants of good action. Three are both rootless and inoperative. In all, therefore, there are eighteen rootless states.

361. The third main category comprises “beautiful” states; all, therefore, associated with good roots. Of these, some being the action of worldly persons, they are thereby resultant producing states. Some, being the outcome of such action, are resultants. Whereas others, being the actions of the arahanta, are inoperative. Thus: Eight have good roots and are resultant producing. Eight have good roots and are themselves resultants. Eight have good roots and are inoperative. In all, therefore, there are twenty-four beautiful Kāmāvacara states. Totalling these three main categories there are fifty-four integral conscious states Characteristic of the Plane of Sense Desire.

362. This total of fifty-four states is confirmed in yet another way wherein the individual totals are arrived at purely in terms of resultant states, resultant producing states, and inoperative states. Thus Abhidhammatthasaṅgaha verse 20 presents the following mnemonic stanza:

VERSE 20

KAME TEVĪSA PAKANI
PUNN ĀPUNNĀNI VĪSATI
EKĀ-DASA KRIYĀ CETI
CATU-PAÑÑĀSA SABBATHĀ

Meaning:

IN integral consciousness Characteristic of the Plane of SENSE DESIRE (*kāme*) there are TWENTY-THREE (*te-vīsa*) RESULTANTS (*pākāni*), TWENTY (*vīsati*) MERITORIOUS and IMMERITORIOUS (*pun apunnani*) states, ALSO (*ca*) ELEVEN (*eka-dasa*) IMPERATIVES (*kriyā*); THUS (*iti*) FIFTY-FOUR (*catu-paññāsa*) IN ALL (*sabbathā*).

363. In discussing the fifty-four kāmāvacara states, frequent reference has been made to important features of the Buddha’s Teaching: thus, causality, the active conscious process and existence as a continuity of process, have repeatedly been spoken of. In all these examples the logical principle of “this arising because of that” has not been difficult to accept; moreover, it is particularly helpful in explaining the value of moral practice, mental development, and wisdom. However, within that logic the characteristic of IMPERMANENCE (*anicca*) must always be stressed; thus, where any causal function is considered in terms of its participant states it is vital

to appreciate that each such state arises, functions, ceases. Consequently each serial instant of consciousness throughout the continuity of process is impermanent. From this, continuity itself is recognizable merely as a phenomenon, manifest only because of the adjacency of impermanent states. As a phenomenon it can have no permanent essence, it is therefore WITHOUT SOUL (*anattā*). Furthermore, because the entire seriality of functions is perpetuated by IGNORANCE (*avijjā*) and its activity through CRAVING (*tanhā*), the characteristic of SUFFERING (*dukkha*) is perpetually evident. Thus, as the Buddha proclaimed, the THREE CHARACTERISTICS (*ti-lakkhana*) of existence are Impermanence, Suffering, and Absence of Soul, i.e., *anicca, dukkha, anattā*.

364. That completes the section dealing with integral conscious states Characteristic of the Plane of Sense Desire.

ABHIDHAMMATTHASAṄGAHA Talk No. 7 (Part 2)

SUBLIME CONSCIOUSNESS (Mahāggata Citta).

365. In the mātikā of Dhammasaṅgani there is a sub-section in the groups of three which categorizes the entirety of states or phenomena under the headings LOW (*paritta*), SUBLIME (*mahaggata*) and IMMEASURABLE (*appamana*).¹⁴³

366. In the first of these three, i.e., low, there are brought together all phenomena Characteristic of the Plane of Sense Desire, including thereby all good (productive) states, bad (productive) states, resultant states, and inoperative states, together with the mental qualities and factorial consciousness concomitant with their arising. In addition to these purely MENTAL QUALITIES (*nāma*) this category of LOW STATES (*paritta-dhamma*) also includes MATERIAL QUALITIES (*rūpa*).

367. The word "low," a translation of "paritta," is variously rendered as insignificant, trifling, limited, circumscribed, little, weak, brief and minor; moreover, the Commentary Atthasālini, in discussing the inclusion of Kāmāvacara consciousness, etc., within the group of low states, does in effect demonstrate these several values by saying that such states, "are comparable with a pat of cow-dung."¹⁴⁴ When given some consideration, this is a most apt simile, for not only does it emphasize their minor, trifling and insignificant nature when compared with the far more advanced, controlled and penetrative modes of thought, but at the same time illustrates the clearly defined manner in which, as a class of states, they are circumscribed and cut off from all more developed mental practice. Furthermore, as states Characteristic of the Plane of Sense Desire they are limited and unable to spread beyond the confinement imposed by the objects of sight, sound, etc., associated with their coming to be. Then again, they are brief and weak inasmuch as the duration of any Kāmāvacara course of active conscious process is fixed within close limits and cannot be extended beyond those limits. Consequent upon this it can be appreciated that although, as has been shown, the penetrative ability of the more powerful three-rooted good (productive) integral states of this class may indeed reach to the very frontier point between mundane understanding and true supramundane penetrative insight, the lack of real strength in such states, together with the relative briefness of their duration, renders any truly consecutive attention and undisturbed concentration difficult and uncertain of achievement.

368. Thus it is that although the integral conscious states grouped together under the name Kāmāvacara-citta represent collectively nine more (i.e., 8 *sobhanā kiriya* and 1 *ahetuka kiriya*) than the entire range of mental states occurring to the average person, and serving every occasion throughout his whole life, they are, nevertheless, in terms of fundamental mental development leading towards penetrative insight, capable of being regarded as nothing other than LOW (*paritta*).

369. From what has been said of the limitations of Kāmāvacara states, and of the earlier mention of the two additional headings of Sublime and Immeasurable included in Dhammasaṅgani mātikā, it is apparent that there can occur certain other integral conscious states which are in some special way superior, and which, for an associated reason, are not ordinarily experienced by the average person. Putting on one side, therefore, any examination of the very particular and quite unique supramundane states which alone are possessed of true

¹⁴³ I.e., Tika No. 12; see also B.P.E., Matika p. 1, no. 12, also pars. 1019-21.

¹⁴⁴ See also Exp. p. 58.

penetrative insight, and which, because of that insight, are to be regarded as IMMEASURABLE (*appamana*), there still remains to be investigated the very important group of integral states classified as SUBLIME (*mahaggata*).

370. Without understating the innate capacity of a sufficiently strong good (productive) three-rooted Kāmāvacara state actually to stand in the relationship of being proximate to (i.e., of being the integral state that arises and passes away immediately prior to) the coming to be of true supramundane penetrative insight,¹⁴⁵ it is nevertheless readily recognizable that in a more general sense such low states can be said to be unsteady and wavering. Moreover, they lack calm and stability, and, due to the powerful influence of craving, their tendency is to lack concentration to a serious degree and thus to arise more or less fitfully on one object of sense after another. What is the reason for this, and what alternative is there?

371. As low states the fundamental reason is, of course, their nearness to ignorance and craving, this being particularly apparent in the case of the twelve bad (productive) states. However, as has already been lightly touched upon with regard to the FETTERS (*samyojana*), ignorance, and craving are endemic to the whole condition of existence, much as individual maladies are endemic to particular areas of the world. Moreover, exactly as with endemic diseases, they remain ready to become powerfully operative at any time. Because of this characteristic quality, ignorance and craving are in a perpetual state of preparedness to block, hinder or otherwise impede the existence of any salutary development, and will so continue to be until by one means or another they are inhibited, or, better still, finally eradicated. What, then, is the most common way in which ignorance and craving are endemically active so as to hinder advancement and thereby perpetuate the low states?

372. The most common way is by the ever present influence of the FIVE HINDRANCES (*pañca-nīvaranāni*), which are:

1. WISH FOR SENSE PLEASURE (*kāmacchanda*).
2. ILLWILL (*byapada*).
3. SLOTH AND TORPOR (*thina-middha*).
4. DISTRACTION AND REMORSE (*uddhacca-kukkucca*).
5. DOUBT (*vicikicchā*).

373. It is not necessary at this point to discuss these five in further detail, for, from their very titles, the manner in which each is equated with one or other of the bad roots, and thus ultimately with ignorance and its associated craving, is readily recognizable. So far, REMORSE (*kukkucca*), is the only one which has not already been discussed in some form. This, as self-anger or worry, functions as a mental concomitant occurring in certain hateful states of consciousness, and therefore in conjunction with the roots of HATRED (*dosa*) and DULLNESS AND DELUSION (*moha*). As a mental concomitant it will be spoken of in greater detail in chapter 2 of Abhidhammatthasaṅgaha; in the present context, however, it is looked upon as one of the hindrances where it occurs conjointly with DISTRACTION (*uddhacca*), a quality never associated with hatred but to which remorse nevertheless bears a certain affinity.

374. It is evident that this group of five hindrances constitutes a significant obstacle to the ability of consciousness to arise and dwell for any considerable length of time on a given object; in other words, as a group they inhibit the ability to concentrate. In this connection it is well to stress the importance of RIGHT EFFORT (*samma-vāyāma*), RIGHT MINDFULNESS (*samma-sati*), and RIGHT CONCENTRATION (*samma-samādhi*) as elements of the NOBLE EIGHT

¹⁴⁵ See C.S. ed. of Patthāna, vol. 2, p. 326.

CONSTITUENT PATH (*ariya-atthangika-magga*) mentioned earlier.¹⁴⁶ In the function of that path as a way leading from SUFFERING (*dukkha*) to the CESSATION OF SUFFERING (*dukkha-nirodha*), those three elements are particularly associated with MENTAL DEVELOPMENT (*bhāvanā*); in practical matters concerned with achieving concentration, therefore, they are of paramount importance.

375. From this, the inference to be drawn is that for progress to be made by means of the Noble Eight Constituent Path towards the attainment of penetrative insight, it is necessary that the five hindrances should at the very least be inhibited. It is also apparent that if there be five individual hindrances, each requiring, as it were, to be burnt out or cauterised prior to the possibility of there being really effective concentration, some special kind of exercise or training must be employed whereby those path constituents are able to play their part. Considered, therefore, from a purely analytical, but at the same time very practical point of view, the effectivity of the hindrances needs to be counteracted by integral conscious states exercising Right Effort, Right Mindfulness and Right Concentration; and wherein the structure, balance and dominance of MENTAL CONCOMITANTS (*cetasika*) is such that the individual hindrances are effectively cauterized by mental concomitants specifically opposed to them in respect of General Characteristic, and so on.

376. That the most suitable Kāmāvacara states can be much improved in respect of ability to concentrate, is evident from the previous mention of their being able when fully developed to stand proximate to the arising of supramundane states. Consequently, any properly directed training specifically applied in conjunction with MORAL PRACTICE (*sīla*) to improve the ability to concentrate by way of RIGHT EFFORT (*samma-vāyāma*), RIGHT MINDFULNESS (*samma-satī*) and RIGHT CONCENTRATION (*samma-samādhi*), fulfils the basic requirements for MENTAL DEVELOPMENT (*bhāvanā*) that is able to lead eventually to supramundane penetrative insight. Nevertheless, such individual sequences of Kāmāvacara conscious process are still limited as to duration; and, because of incompletely established inhibition of hindrances, are liable to deviate from their object of concentration and to fall back to lower grade states. Therefore, if as an aid towards stability, increase and maturity in the path of progress, concentration of the highest order is deemed desirable, then training in the strengthening of Kāmāvacara consciousness has to be directed specifically to the ultimate development of more advanced types of integral states. Such, are those by means of which not only are the five hindrances completely inhibited, but by which, with their full development, the limitation of duration is also overcome. Thus, in such advanced states, not only are the javana instants of full awareness more powerful and brilliant, but by careful and scrupulous training are able to be extended to far beyond the seven instants imposed by Kāmāvacara states.

377. States which achieve this higher standard of development very naturally fall outside the limits within which they are classifiable as Kāmāvacara, and thereby as “low;” in consequence, therefore, of their strongly enhanced ability to concentrate and to inhibit hindrances, they constitute an entirely different category. As such they are known as Mahāggata states, meaning “states which have reached greatness.” In translation, however, they are customarily referred to as Sublime or Exalted, and of them the Commentary Atthasālini, says:¹⁴⁷

“From proficiency in inhibiting corruption, from magnitude of fruition, from length of duration, they have reached the condition of being great; also, from their having been attained to by great

¹⁴⁶ See par. 301.

¹⁴⁷ See also Exp. p. 58.

persons who, with exalted aspiration, energy, consciousness, and understanding, have followed the path of practice, they are thus Sublime.”

378. In the case of Kāmāvacara states, as the name suggests, their characteristic quality is “a wandering about in” or “a being-much concerned with” a multiplicity of objects of sense desire. In sharp contrast to this, Mahāggata states operate on a basis of very much reduced sense desire, inasmuch as they depend for their object not on the direct activity of the five physical senses but on the mind-door only. As a separate and clearly defined category of states they are divided into two distinct but clearly associated groups bearing the names Rūpāvacara-citta and Arūpāvacara-citta respectively.

379. The first group, Rūpāvacara-citta, translated as integral Consciousness Characteristic of the Plane of Form, consists basically of a group of five conscious states differentiated from each other by characteristically structured arrangements of dominant mental concomitants accompanying factorial consciousness. Although as Rūpāvacara states they stand in a category higher and more powerful than Kāmāvacara-citta, and depend for their arising upon the mind-door and a conceptualized object only, they are in certain respects beholden to Kāmāvacara states. The reason for this is that initially they come into being as the outcome of hard, meticulous, and specifically directed practice obtaining at a particular juncture. That juncture occurs when, after a succession of courses of Kāmāvacara active conscious process associated with a being whose bhavaṅga¹⁴⁸ has three good roots, a degree of concentration and stability is attained wherein the obstructive effect of the five hindrances is reduced to a condition where each is exactly balanced, and thus effectively inhibited by an individual mental concomitant possessing qualities diametrically opposed to it. To the extent, therefore, that appropriate Kāmāvacara states perform the preliminary work, and thereby give access to the complete absorption characteristic of Mahāggata states, these latter are beholden to them.

380. When, as one of the two classes of SUBLIME CONSCIOUS STATES (*Mahāggata-citta*) the term Rūpāvacara is used, what is implied by this? Here it is useful to consider the substance of what was said earlier regarding Kāmāvacara.¹⁴⁹ There it was shown that the word is applied in two distinct senses; first to name a group of conscious states characteristically and widely concerned with objects of sense desire, then secondly to give a name to that which may be considered the “natural habitat” of those states. Furthermore, the connection between the two usages was shown inasmuch as certain resultants of those conscious states perform functions at the time of death whereby the continuity of process is maintained by the occurrence of rebirth of beings within the compass of that same natural habitat. Thus Kāmāvacara is twofold in meaning, and because of that is translated as Characteristic of the Plane of Sense Desire.

381. A similar pattern of definitions may be applied to the term Rūpāvacara. In the first sense it is used to name a particular group of conscious states, which although themselves arising on a mental object, are yet looked upon as having a material object, due to their having been initiated by preceding states taking and concentrating on objects classified as MATERIAL (*rūpa*); or, as is appropriate, VISIBLE (*rūpa*)—as for example the earth kasiṇa, etc. In the second sense it is used to name the natural habitat of those particular states, which because of their being intrinsically devoid of the five hindrances can in no way be considered as Characteristic of the Plane of Sense Desire, even though with specific training they can be caused to arise by beings of that plane. Furthermore, the connection between the two usages is shown inasmuch as in suitable circumstances the resultants of appropriate Rūpāvacara states perform functions at the time of

¹⁴⁸ I.e., the constituent potentiality of being, see par. 240.

¹⁴⁹ See pars. 46, 314/315.

death, whereby the continuity of process is maintained by the occurrence of rebirth of beings within the compass of the natural habitat of those states. Thus Rūpāvacara is twofold in meaning, and because of that is translated as Characteristic of the Plane of Form.

382. Incidental to these definitions of Kāmāvacara and Rūpāvacara it should be appreciated that with the classifications of conscious states characteristic of this or that natural habitat, the existence of specific categories of beings born into and characteristic of those abodes is also intended.

383. Somewhat earlier it was said that for there to be effective concentration it is essential that each of the five individual hindrances be burnt out or cauterized by the dominant presence of certain mental concomitants possessed of individual qualities diametrically opposed to them.¹⁵⁰ Here, the expressions „burnt out” and “cauterized” were used with specific purpose, a purpose which in this context involves the meaning of concentration also. In this connection the integral states enumerated in verses 21, 22 and 23 of Abhidhammatthasaṅgaha are of considerable importance, for in these verses are shown the five basic forms of Rūpāvacara states, forms which are characterized by their individual constitutions in terms of dominant mental concomitants. However, because these five basic forms are equally applicable to good (productive), resultant or inoperative states, the resulting total is fifteen instead of five.

384. An immediately noticeable feature of these fifteen states is that each is associated with the word “jhāna.” What is the meaning of this word, and why is it used? The word “jhāna” is nowadays customarily left untranslated, for although its meanings are clear and quite specific it is nevertheless very difficult to find any suitable English word capable of conveying these meanings. Ultimately it springs from the Pali linguistic root JHE, a basic sound conveying the ideas both of “thinking” and of “burning.” In connection with this, Ven. Buddhaghosa, when discussing in Visuddhimagga the modes of developing Mahāggata states, defined jhāna in the following way:¹⁵¹

“Because of THINKING CLOSELY (*upanijjhāna*) of the object, and because of BURNING UP (*jhāpana*) opposition, it is jhāna.”

Here, “thinking closely of the object” refers to the object of concentration upon which the particular Rūpāvacara integral state has arisen, and with which it is therefore directly concerned. “Burning up opposition” means that whatever adverse conditions have previously opposed the existence of close thinking, or concentration, all are now burnt out or cauterized. Finally, whatever has stood in opposition, or has been adverse to concentration, refers to the obstructive capability of the five hindrances. Thus, in this context “jhāna” refers to the systematic development of very strongly active but completely stabilized integral conscious states which, because of the burning up of the five hindrances, are thereby fully concentrated on their object.

385.¹⁵² Verses 21, 22 and 23 of Abhidhammatthasaṅgaha, enumerating the three categories of integral CONSCIOUSNESS CHARACTERISTIC OF THE PLANE OF FORM (*Rūpāvacara-citta*) are as follows:

¹⁵⁰ See par. 375.

¹⁵¹ See also Ppn. p. 156.

¹⁵² See chart 10.

VERSE 21

VITAKKA-VICĀRA-PĪTI-SUKH EKAGGATA-SAHITAM PATHAMAJJHĀNA-KUSALA-CITTAM

VICĀRA-PĪTI-SUKH EKAGGATĀ-SAHITAM DUTIYAJJHĀNA-KUSALA-CITTAM

PĪTI-SUKH EKAGGATĀ-SAHITAM TATIYAJJHĀNA-KUSALA-CITTAM

SUKH EKAGGATĀ-SAHITAM CATUTTHAJJHĀNA-KUSALA-CITTAM

UPEKKH EKAGGATĀ-SAHITAM PANCAMAJJHĀNA-KUSALA-CITTAN CE TI

IMANI PANCA PI RŪPĀVACARA-KUSALA-CITTĀNI NAMA

Meaning:

The mental concomitants known as:

INITIAL APPLICATION (*vitakka*), SUSTAINED APPLICATION (*vicāra*), ZEST (*pīti*), mental PLEASURE (*sukha*), and ONE-POINTEDNESS (*ekaggatā*) IN MUTUAL ASSOCIATION (*sahita*) with factorial consciousness constitute FIRST (*pathama*) JHĀNA (*jhāna*) GOOD (*kusala*) productive integral CONSCIOUSNESS (*citta*).

(Having with intention eliminated Initial Application, the following mental concomitants:)

Sustained Application, Zest, mental Pleasure, and One-pointedness in mutual association with factorial consciousness constitute SECOND (*dutiya*) Jhāna good (productive) integral consciousness.

(Having with intention eliminated Sustained Application, the following mental concomitants:)

Zest, mental Pleasure and One-pointedness in mutual association with factorial consciousness constitute THIRD (*tatiya*) Jhāna good (productive) integral consciousness.

(Having with intention eliminated Zest, the following mental concomitants:)

Mental Pleasure and One-pointedness in mutual association with factorial consciousness constitute FOURTH (*catuttha*) Jhāna good (productive) integral consciousness.

(Having with intention eliminated mental Pleasure, the following mental concomitants:)

EQUANIMITY (*upekkhā*) and One-pointedness in mutual association with factorial consciousness constitute FIFTH (*pañcama*) Jhāna good (productive) integral consciousness.

THESE (*imāni*) FIVE TOGETHER (*pañca pi*) ARE KNOWN AS (*nāma*) GOOD (*kusala*) productive integral CONSCIOUS STATES (*cittāni*) CHARACTERISTIC OF THE PLANE OF FORM (*Rūpāvacara*).

VERSE 22

386. VITAKKA-VICĀRA-PĪTI-SUKH EKAGGATĀ-SAHITAM PATHAMAJJHĀNA-VIPĀKA-CITTAM

VICĀRA-PĪTI-SUKH EKAGGATA-SAHITAM DUTIYAJJHĀNA-VIPĀKA-CITTAM

PĪTI-SUKH EKAGGATĀ-SAHITAM TATIYAJJHĀNA-VIPĀKA-CITTAM

SUKH EKAGGATĀ-SAHITAM CATUTTHAJJHĀNA-VIPĀKA-CITTAM

UPEKKH EKAGGATĀ-SAHITAM PANCAMAJJHĀNA-VIPĀKA-CITTAM

IMANI PANCA PI RŪPĀVACARA-VIPĀKA-CITTĀNI NĀMA

Meaning:

The mental concomitants known as:

INITIAL APPLICATION (*vitakka*), SUSTAINED APPLICATION (*vicāra*), ZEST (*pīti*), mental PLEASURE (*sukha*), and ONE-POINTEDNESS (*ekaggatā*) IN MUTUAL ASSOCIATION (*sahita*) with factorial consciousness constitute FIRST (*pathama*) JHĀNA (*jhāna*) RESULTANT (*vipāka*) integral CONSCIOUSNESS (*citta*).

Sustained Application, Zest, mental Pleasure, and One-pointedness in mutual association with factorial consciousness constitute SECOND (*dutiya*) Jhāna resultant integral consciousness.

Zest, mental Pleasure and One-pointedness in mutual association with factorial consciousness constitute THIRD (*tatiya*) Jhāna resultant integral consciousness.

Mental Pleasure and One-pointedness in mutual association with factorial consciousness constitute FOURTH (*catuttha*) Jhāna resultant integral consciousness.

EQUANIMITY (*upekkhā*) and One-pointedness in mutual association with factorial consciousness constitute FIFTH (*pañcama*) Jhāna resultant integral consciousness.

THESE (*imāni*) FIVE TOGETHER (*pañca pi*) ARE KNOWN AS (*nāma*) RESULTANT (*vipāka*) integral CONSCIOUS STATES (*cittāni*) CHARACTERISTIC OF THE PLANE OF FORM (*Rūpāvacara*).

VERSE 23

387. VITAKKA-VICĀRA-PĪTI-SUKH EKAGGATA-SAHITAM PATHAMAJJHĀNA-KIRIYA-CITTAM

VICARA-PĪTI-SUKH EKAGGATĀ-SAHITAM DUTIYAJJHĀNA-KIRIYA-CITTAM

PĪTI-SUKH EKAGGATĀ-SAHITAM TATIYAJJHĀNA-KIRIYA-CITTAM

SUKH EKAGGATĀ-SAHITAM CATUTTHAJJHĀNA-KIRIYA-CITTAM

UPEKKH EKAGGATĀ-SAHITAM PANCAMAJJHĀNA-KIRIYA-CITTAM

IMĀNI PANCA PI RŪPĀVACARA-KIRIYA-CITTĀNI NĀMA

Meaning:

The mental concomitants known as:

INITIAL APPLICATION (*vitakka*), SUSTAINED APPLICATION (*vicāra*) ZEST (*pīti*), mental PLEASURE (*sukha*) and ONE-POINTEDNESS (*ekaggatā*) IN MUTUAL ASSOCIATION (*sahita*) with factorial consciousness constitute FIRST (*pathama*) JHĀNA (*jhāna*) INOPERATIVE (*kiriya*) integral CONSCIOUSNESS (*citta*).

(Having with intention eliminated Initial Application, the following mental concomitants:)

Sustained Application, Zest, mental Pleasure, and One-pointedness in mutual association with factorial consciousness constitute SECOND (*dutiya*) Jhāna inoperative integral consciousness.

(Having with intention eliminated Sustained Application, the following mental concomitants:)

Zest, mental Pleasure and One-pointedness in mutual association with factorial consciousness constitute THIRD (*tatiya*) Jhāna inoperative integral consciousness.

(Having with intention eliminated Zest, the following mental concomitants:)

Mental Pleasure and One-pointedness in mutual association with factorial consciousness constitute FOURTH (*catuttha*) Jhāna inoperative integral consciousness.

(Having with intention eliminated mental Pleasure, the following mental concomitants:)

EQUANIMITY (*upekkhā*) and One-pointedness in mutual association with factorial consciousness constitute FIFTH (*pañcama*) Jhāna inoperative integral consciousness.

THESE (*imāni*) FIVE TOGETHER (*pañca pi*) ARE KNOWN AS (*nāma*) INOPERATIVE (*kiriya*) integral CONSCIOUS STATES (*cittāni*) CHARACTERISTIC OF THE PLANE OF FORM (*Rūpāvacara*).

388. This is followed by a summary confirming the categories of states involved, together with their total.

VERSE 24

ICCEVAM SABBATHĀ PI PAÑÑĀRASA RŪPĀVACARA-KUSALA-VIPĀKA-KIRIYA-CITTĀNI SAMATTĀNI

Meaning:

THUS (*iccevam*) FROM EVERY ASPECT (*sabbathā pi*) the FIFTEEN (*paññārasa*) GOOD (*kusala*) productive, RESULTANT (*vipāka*) and INOPERATIVE (*kiriya*) integral CONSCIOUS STATES (*cittāni*) CHARACTERISTIC OF THE PLANE OF FORM (*Rūpāvacara*) are FULLY COMPLETED (*samattāni*).

389. From the content of these verses it is apparent that inherent in the five basic structures of the integral states concerned, the dominant mental concomitants variously involved are INITIAL APPLICATION (*vitakka*), SUSTAINED APPLICATION (*vicāra*), ZEST (*pīti*), mental PLEASURE (*sukha*) and ONE-POINTEDNESS (*ekaggatā*). In a later chapter of *Abhidhammatthasaṅgaha*, it is shown how in these very same states many other mental concomitants besides these are likewise operative in mutual association with factorial consciousness. However, the presence of these particular five dominant qualities is stressed not only that they may identify the essential differences existing between the individual states themselves, but also to emphasize the concomitant part they play by completely inhibiting the five hindrances; obstructive qualities which would otherwise preclude the existence of any Mahāggata states whatsoever.

390.¹⁵³ With this in mind, and before inquiring into the individual qualities lying behind the names of these five CONSTITUENTS OF JHĀNA (*jhānaṅga*), it is necessary to observe the direct relationship existing between them and the five hindrances. Thus:

The hindrance of WISH FOR SENSE PLEASURE (*kāmacchanda*) is inhibited by ONE-POINTEDNESS (*ekaggatā*).

The hindrance of ILLWILL (*byāpāda*) is inhibited by ZEST (*pīti*).

The hindrance of SLOTH AND TORPOR (*thina-middha*) is inhibited by INITIAL APPLICATION (*vitakka*).

The hindrance of DISTRACTION AND REMORSE (*uddhacca-kukkucca*) is inhibited by mental PLEASURE (*sukha*).

The hindrance of DOUBT (*vicikicchā*) is inhibited by SUSTAINED APPLICATION (*vicāra*).

Thus the FIVE HINDRANCES (*pañca-nīvaranāni*) are inhibited by the FIVE CONSTITUENTS OF JHĀNA (*pañca-jhānaṅgāni*).

391. The importance attached to such a relationship in respect of opposition to hindrances, and from that to the realization of the effects of their complete abandonment, is exemplified in a stanza spoken by the Buddha and included in the early part of *Suttanipāta*.¹⁵⁴ Here, referring not just to the inhibition, or temporary suppression, of the hindrances such as occurs in the case of good (productive) Mahāggata states, but to their utter abandonment and dissolution by those who attain to the final stage of absolute penetrative insight, the Buddha says:

“He who has abandoned the five hindrances is one free from suffering, one passed beyond uncertainty, one free from the (five) arrows (of lust, hatred, dullness, conceit and wrong view); that bhikkhu discards this world and beyond as a snake its old, worn out skin.”

392. Thus although this stanza refers to the arahanta, fully released from the rounds of rebirth and therefore with hindrances completely eliminated, the cultivation of Mahāggata states by those who are skilful, but as yet unreleased, represents an aspect of MENTAL DEVELOPMENT (*bhāvanā*) whereby those hindrances may at least be temporarily subjugated to facilitate forward progress to that ultimate goal wherein they reach final and utter destruction.

¹⁵³ See chart 11.

¹⁵⁴ Sn., Uragavagga 7.

ABHIDHAMMATTHASAṄGAHA Talk No. 8 (Part 1)

393. When the expression “the cultivation of Mahāggata states” is used, it refers to a particular aspect of MENTAL DEVELOPMENT (*bhāvanā*), just as the phrase, “... seeing peril in his slightest faults, observing the precepts ...¹⁵⁵” refers to aspects of MORAL PRACTICE (*sīla*). The accomplishment of mental development is, however, a working bond between these two; and, as has already-been shown, consists of a process of building up the strength of mindfulness, energy, concentration and stability to a point where, backed by moral practice, the five constituents of jhāna inhibit the five hindrances.

394. Practice of this kind directed to the cultivation of Mahāggata states is thus a branch of mental development, and as such is known as MENTAL DEVELOPMENT OF CALM (*samatha bhāvanā*). Here, however, it should be appreciated that CALM (*samatha*) is just one of the several synonyms for CONCENTRATION (*samādhi*), which by the Abhidhamma Analysis of Vibhaṅga is described as, “... stability, steadfastness, firmness of consciousness, non-distraction, non-wavering, calmness, ... RIGHT CONCENTRATION (*samma samādhi*).” In this way, therefore, mental development of calm means practice directed to the achievement of concentration by way of Mahāggata states.

395. This form of practice is quite distinct from, and not to be confused with MENTAL DEVELOPMENT DIRECTED TO INSIGHT (*vipassanā bhāvanā*), which is concerned exclusively with the gaining of penetrative insight into IMPERMANENCE (*anicca*), SUFFERING (*dukkha*) and ABSENCE OF SOUL (*anattā*). Nevertheless, although the achievement of Mahāggata states is not mandatory to the attainment of insight, it is an exercise of the greatest assistance towards mental development directed to the gaining of that stability which is the outcome of the inhibition of the five hindrances; to that extent, therefore, the cultivation of Mahāggata states can be accessory to the development of penetrative insight. However, insight gained either with or without the assistance of Mahāggata states nevertheless embraces all the three aspects of the Buddha’s Teaching, i.e., MORAL PRACTICE (*sīla*), MENTAL DEVELOPMENT (*bhāvanā*), and WISDOM (*paññā*).

396. But to return to the five constituents of jhāna which as mental concomitants stand in opposition to, and, when dominant, inhibit the five hindrances. At first sight the meanings of the names they bear in translation are not always easy to comprehend, as for example “initial application” and “sustained application.” If, though, the part they play in integral conscious states is understood, this becomes clearer.

397. At an earlier stage¹⁵⁶ the word “citta,” consciousness, was rendered in two ways. This was done to avoid confusion as to whether it signified the simple condition of awareness, or, alternatively, a compounded state, i.e., a citta-cetasika-dhamma, comprising that same simple awareness but together with relevant mental concomitants, thereby enabling the many different states to be discriminated one from another. This simple awareness was called “factorial consciousness,” and the compounded form “integral consciousness.” In this latter sense, however, it has to be appreciated that the various qualities concomitant with consciousness are not “things” stored and waiting, as it were, to be taken from a peg to be arrayed around consciousness rather as clothing. On the contrary, an integral state is a unity whereby concomitant qualities arise, exist, and pass away together with awareness, as aspects of that unity and as modes by which that unity may be interpreted. Thus they cannot be differentiated

¹⁵⁵ B.o.A. pars. 515/516.

¹⁵⁶ See pars. 40 & 45.

from that unity other than by names descriptive and deducible from the manner in which that unity occurs as a compounded state.

398. In this context, therefore, as an explanation in brief, when the term INITIAL APPLICATION (*vitakka*) is used, it signifies a quality inherent in the conscious state whereby there occurs the “first taking up of the object,” or the “introductory lifting itself on to the object.” SUSTAINED APPLICATION (*vicāra*) signifies its further investigation of the object. ZEST (*pīti*) is its enthusiasm, its freshness, its satisfaction in the object. PLEASURE (*sukha*) is that condition which in conformity with satisfaction is PLEASANT MENTAL FEELING (*somanassa-vedanā*). ONE-POINTEDNESS (*ekaggatā*) is concentration, representing thereby the degree of unification manifest in the state as a whole.

399. Looking more closely into the inhibition of the hindrances by these constituents of *jhāna*, the qualities involved need to be compared one with the other. Thus in considering the keeping aloof from “wish for sense pleasure,” by means of “one-pointedness” of consciousness; the nature of “wish,” together with “sense pleasure” or “sense desire,” is to be recognized in its arising primarily as the manifestation of craving and greed.

400. WISH (*chanda*) constitutes the searching aspect of craving and greed; for “wish” has the General Characteristic of “a desire to do,” coupled with an Inherent Functional Property of “seeking for an object.” Its direct association with craving and greed is shown in its Resultant Appearance and Concurrent Footing, in so far as both are “a condition of wanting an object.” As is said in *Visuddhimagga*¹⁵⁷ “wish” is, in effect, “... the stretching out a mental hand to grasp an object.” As to the General Characteristic of greed itself at the time when an object has been mentally seized, it is, as has already been shown, “... the cleaving to an object of sense in the manner of the stickiness of a spider’s web.”¹⁵⁸

401. Regarding SENSE PLEASURE or SENSE DESIRE (*kāma*), this is frequently referred to as THE FIVE STRANDS OF SENSE PLEASURE (*pañca-kāma-guṇā*), and represents the arising and activity of consciousness by way of the five doors of physical sense in respect of the five stimuli, i.e., the visible, the audible, the odorous, the sapid and the tangible, each of which in terms of feeling can be causative of sense pleasure. To these five is added the arising of consciousness at the mind door; a sixth door, whereby wish for sense pleasure in respect of ideational objects is temporarily stimulated, but, as with the other five, is in no way permanently assuaged.

402. Thus it is that in craving and greed, with their insatiable seeking for pleasurable satisfaction from objects both mental and material, there exists in “wish for sense pleasure” a formidable hindrance to effective concentration and to mental calm and stability.

403. In order that, for the cultivation of Mahāggata states, “wish for sense pleasure” may be temporarily suspended and the condition of being “... aloof from sense pleasure¹⁵⁹” realized, it is most important that a feature axiomatic to the study of Abhidhamma be adequately recognized. It is that on no occasion can more than a single integral state arise at one and the same time. This means that at the instant a preceding state comes to cessation it is followed immediately by the instant of genesis of a succeeding state, there is neither overlapping nor superimposition. A conscious state is impermanent, it comes to be, exists, passes away; and is followed, there and then, by yet another impermanent conscious state performing its appropriate function and passing away, and so on; a stream of individual but related

¹⁵⁷ See also Ppn. p. 527.

¹⁵⁸ See par. 74.

¹⁵⁹ See B.o.A. par. 564.

impermanent instants of consciousness proceeding inexorably until the combined driving forces of ignorance and craving are utterly annihilated, and thereby the productive activity of the causal series brought to an end.

404. The reason for emphasizing this point is to show that while there continues to take place a virtually automatic and unregulated arising of conscious states associated with sense pleasure, what is occurring is an uncontrolled “free-wheeling” of the mind directed by and strengthening to the combined power of ignorance and craving. If, though, there is watchfulness and control, the arising of conscious states ceases to be unregulated, and instead becomes directed by the power of skilful mental concomitants operating conjunctly with factorial consciousness. In this sense, therefore, if an object be specifically chosen, not with the aim of satisfying sense desire but with the determination of holding it mentally for the sole purpose of calming, stabilizing and concentrating the attention of consciousness upon it alone, a very different situation is produced. Thus if, as is axiomatic, one state only can exist at a time, then while—because of concentration—“wish for sense pleasure” is excluded, it is evident that it cannot at the same time be present. To that extent, therefore, it is inhibited.

405. With the mention of the need for watchfulness in order to keep “aloof from sense pleasure,” what is more particularly referred to is the proper observance of the Noble Eight Constituent Path, and thereby the practice of Right Effort, Right Mindfulness and Right Concentration. The importance of this to the present question is well illustrated in a passage from the Cūlavedalla Sutta,¹⁶⁰ where there took place a conversation between the bhikkhunī Dhammadinna, and the upāsaka Visakha. There, in answering a question concerning the internal classifications of the Noble Eight Constituent Path, the bhikkhunī says:

“... that which is Right Effort, that which is Right Mindfulness and that which is Right Concentration, these qualities are grouped together in the category of concentration.”

(Visakha questions further):

“What then, Madam, is concentration, what things are the objects of concentration, what qualities are the requisites for concentration, what is the development of concentration?”

“Indeed, friend Visakha, that which is one-pointedness of consciousness, this is concentration; the four foundations of mindfulness are the objects of concentration; the four right-strivings are the requisites for concentration. That which is the pursuit, the development, the repetition of just these things; in this context this is the development of concentration.”

406. From this it can be seen that whatever is effort, mindfulness, and concentration itself, each is an essential aspect of concentration as a whole. Moreover, from the sutta quoted, it is clear that CONCENTRATION (*samādhi*) is ONE-POINTEDNESS OF CONSCIOUSNESS (*cittassa ekaggatā*). Therefore, when it is said that “wish for sense pleasure” is inhibited by “one-pointedness,” it means that undeviating concentration on a suitable object not associated with sense pleasure, effectively puts on one side the incursion of “wish for sense pleasure.”

407. Of “one-pointedness” the Commentary Atthasālini, says,¹⁶¹

“This that is called ‘one-pointedness of consciousness’ is a name for concentration; not wandering (absence of diffuseness), or non-wavering, is its General Characteristic; the integration of conascent states, its Inherent Functional Property, like water with bath powder. Calmness, or knowledge, is its Resultant Appearance; indeed it was said: ‘He who is

¹⁶⁰ See also M.L.S. vol. 1, p. 363.

¹⁶¹ See also Exp. p. 156/7.

concentrated knows, sees, 'as it really is.' In most instances pleasure (lit. pleasant mental feeling) is its Concurrent Footing. Like the steadiness of a lamp flame in the absence of wind, thus should mental steadiness be understood."

408. Here, a comparison between these four denotations and those of "wish for sense pleasure" is most revealing, for it illustrates clearly why "one-pointedness" is so effective in inhibiting that hindrance. Thus, whereas "wish" is characterized by the inherent instability and fretfulness of a constant "desire to do," concentration is steady, it does not wander or waver. Then, whereas "wish" seeks the stimulation produced by a new object; concentration, satisfied with its single object, gains added strength by uniting ever more completely factorial consciousness and its concomitant qualities. Finally, whereas—because of greed and craving—"wish" demonstrates continuously its strong desire for fresh objects; concentration, having no such sense desire, is instead possessed of confidence, calmness and knowledge, together with the contentment born of mental ease and pleasure. From this it can be seen that "wish" is negated in every direction by concentration; therefore it is said, "Wish for 'sense pleasure' is inhibited by 'one-pointedness.'"

| | WISH | CONCENTRATION |
|-------------------------------|------------------------|------------------------------------------------------|
| General Characteristic. | A desire to do. | Not wandering absence of diffuseness). Non-wavering. |
| Inherent Functional Property. | Seeking for an object. | The integration of conscent states. |
| Resultant Appearance. | Wanting an object. | Calmness, knowledge. |
| Concurrent Footing. | Wanting an object. | Mental pleasure. |

409. In so far as the inhibition of "wish for sense pleasure" by "one-pointedness" demonstrates the temporary suppression of the bad root of greed, so in a comparable sense the inhibition of "illwill" by "zest" represents the temporary suppression of the bad root of hatred. ILLWILL (*byapada*) is an unskilful aspect of mental activity wherein there is hostility, resentment, and displeasure. Coupled with this, illwill has an insidiously corrupting quality which, by its repeated presence, produces a mental climate favourable to the further harbouring of hostility. Consequently, where this occurs to a cumulative degree it creates a habitual surly, resentful attitude.

410. Of illwill the Commentary says,¹⁶² "Illwill (as root) is the bad root of hatred, illwill (in terms of feeling) has painful feeling." The same Commentary also says,¹⁶³ "One has illwill; by that, consciousness reaches the condition of being putrid, or, it causes ruination of the practice of discipline, of (personal) beauty, of benefit, of happiness and so on; thus is the meaning of illwill. As to its import, though, it is just hatred."

411. As illwill is ultimately HATRED (*dosa*), its four denotations have already been examined in the discussion of that root;¹⁶⁴ however, in order that it may be appreciated how these individual qualities can be overcome by the third constituent of jhāna, known as "zest," they are now restated in summary form: thus the General Characteristic of hatred is ferocity; its Inherent

¹⁶² See also Exp. pp. 134-135.

¹⁶³ See also Exp. p. 342.

¹⁶⁴ See par. 145.

Functional Property, writhing or burning; its Resultant Appearance, that of being hateful; and its Concurrent Footing, having grounds for vexation.

412. In sharp contrast to these denotations are the non-hateful qualities of *pīti*. *Pīti*, although commonly translated as “zest,” is based on the term *pīnayati*, thereby encompassing the notions of being causative of gladness, satisfaction, and invigoration; moreover, according to context, for zest can also occur in bad states, it can be looked upon as pleasurable anticipation, or even rapture. It is, however, in no sense to be confused with any aspect of feeling, for although it is often present at the same time as pleasant feeling it is more akin to enthusiasm. Following the Commentary¹⁶⁵ the denotations of “zest” are as follows:

“Fondness is its General Characteristic; gladdening, its Inherent Functional Property; elation, its Resultant Appearance.”

The Concurrent Footing of “zest” is not stated directly, but in this particular instance, as concomitant to a kusala state, it represents a delight in the object stemming from the absence of self-blame or remorse inherent in the conscious state as a whole, which, from abstention (from the unskillful), has morality as its General Characteristic.¹⁶⁶

413. As to the inhibiting effects of “zest” upon “illwill,” this can readily be seen when their respective denotations are paired with each other. Thus the ferocity of hatred is inhibited by the fondness “zest” has for its object; the writhing and burning of the poison and fire inherent in hatred, is inhibited by the gladness and satisfaction inherent in “zest.” The Resultant Appearance of “illwill,” which is hatefulness, cannot occur in the presence of that elation which is the Resultant Appearance of “zest;” moreover, where, as in “zest,” there is a fondness, gladness and elation, there cannot exist at the same time any grounds for vexation such as constitute the Concurrent Footing of hatred. Therefore it is said, “illwill’ is inhibited by ‘zest.’”

| | ILLWILL | ZEST |
|-------------------------------|-----------------------|-----------------|
| General Characteristic. | Ferocity. | Fondness. |
| Inherent Functional Property. | Writhing, burning. | Gladness. |
| Resultant Appearance. | Being hateful. | Elation. |
| Concurrent Footing. | Grounds for vexation. | (see par. 412). |

414. In practice directed towards the cultivation of Mahāggata states, it has been shown that Right Effort, Right Mindfulness and Right Concentration are constituents of particular importance; moreover, it is apparent that among these the enemy to concentration is “wish for sense pleasure,” the inhibition of which constitutes its temporary suspension by sufficiently powerful one-pointedness of consciousness in respect of a suitable object. Such effective one-pointedness is Right Concentration. In spite of this it can be appreciated that no such Right Concentration can occur without there being at the same time the effort necessary both to bring it about and to maintain it. Effort, though, is an alternative name for ENERGY (*virīya*), for as Vibhaṅga says of effort,¹⁶⁷ it is: “The arousing of mental energy, toiling, perseverance, the power of energy, right effort.” Even so, this effort, as with concentration, has its own particular enemy in the form of a hindrance, this enemy being “sloth and torpor,” the third of the five hindrances.

¹⁶⁵ See also Exp. p. 153.

¹⁶⁶ This additional information is drawn from *Nettipakaraṇa*, C.S. edn. p. 26, and from *Petakopadesa*, C.S. edn. p. 254; see also *The Guide*, p. 50 and *Piṭaka Disclosure*, p. 175.

¹⁶⁷ See B.o.A. pars. 492, also 220.

415. As with the two preceding hindrances, “sloth and torpor” is also inhibited by a constituent of jhāna, in this instance by “initial application” of consciousness. How is this brought about? Here it is important to observe that neither sloth nor torpor is used in its physical sense, for sloth means slothfulness of consciousness, whereas torpor refers to torpidity of feeling, perception and the other relevant mental concomitants. Physical effects such as nodding and sleep may well become apparent, but these arise because of mental conditions; or, in an entirely different context, as a result of strenuous and extended physical exertion as in walking or digging. The Commentarial denotations of these two are as follows,¹⁶⁸ “sloth has absence of zeal as General Characteristic; the dissipation of energy as Inherent Functional Property; sinking down (i.e., losing heart) as Resultant Appearance. Torpor has absence of ability to act, as General Characteristic; enshrouding (of consciousness) as Inherent Functional Property; sluggishness as Resultant Appearance or nodding and sleep as Resultant Appearance. Both have as Concurrent Footing the improper attention inherent in tedium, apathy, restlessness and so on.”

416. In its final sense concentration implies a full and continuous awareness by consciousness of its object. Such is the attainment of one who has developed fully the practice of Mahāggata states. Among the unpractised, however, concentration is relatively weak in so far as consciousness picks up the object of its immediate desire, tires of it, relinquishes it, and picks up another in its stead. Thus in the first instance there is a high degree of controlled, stabilized effort in respect of a single object, whereas in the second there is a multiplicity of successive objects but very little of control, stability or effort. To graduate from the latter to the former involves practice whereby concentration is enhanced by the arousing and application of mental energy, so that instead of the object being mentally dropped it is picked up, again and again.

417. In saying, “the object is picked up again and again,” it implies that mental energy is so directed as to raise consciousness from its state of reluctance and sloth, and to cause it to pay attention yet again to the chosen object. Here, that particular aspect of consciousness constituting its initial engagement with the object is called INITIAL APPLICATION (*vitakka*). Thus, when effort is applied to overcome the slothfulness and torpidity of consciousness and its associated mental concomitants, it is directed to that which Vibhaṅga names, “... the fixation, focussing, application of the mind.”

418. As to the denotations of “initial application,” the Commentary says,¹⁶⁹ “This (initial application) has as General Characteristic the setting up of consciousness upon an object. Indeed, it mounts consciousness upon an object. This (initial application) has as Inherent Functional Property, impinging, circum-impinging; as indeed was said, by means of it one who practises makes consciousness strike an object all round. The Resultant Appearance is the guiding of consciousness on to an object.”

419. By comparing these active qualities with the debilitating effects of “sloth and torpor,” it becomes apparent why the application of effort in the form of a repeated mental picking up of the object is so effective where any proper degree of concentration is to be achieved. Thus the absence of zeal and absence of ability to act, characteristic of “sloth and torpor,” is steadily but positively eroded and overcome by this repeated setting up or mounting of consciousness upon its object by “initial application.” Similarly, the frittering away or dissipation of energy by sloth, and the enshrouding effect of torpor, is dispelled by the repeated “initial application” of consciousness as it strikes again and again at the same object. Furthermore, the sinking down

¹⁶⁸ See also Exp. p. 340 & Ppn. p. 530.

¹⁶⁹ See also Exp. p. 51 & Ppn. p. 148.

and losing heart, the sluggishness, the nodding and sleep which is the Resultant Appearance of "sloth and torpor," is steadily dispersed where "initial application"—an embodiment of effort—guides and re-guides consciousness on to its object.

420. As to the improper attention which forms the basis, or Concurrent Footing, upon which the dual unskilful hindrance of "sloth and torpor" stands and is nourished; where consciousness is being applied in a skilful sense to concentration based upon the removal and non-practice of evil, bad states, a Concurrent Footing of improper attention clearly cannot be present. For these reasons, therefore, it is said, "the hindrance of 'sloth and torpor' is inhibited by 'initial application.'"

421. It was in connection with the identification and inhibition of the hindrances that the Buddha said:¹⁷⁰ "I see no other single thing, Bhikkhus, comparable with the qualities of arousing, toiling, and endeavouring, by means of which unarisen sloth and torpor does not arise and arisen sloth and torpor is abandoned. Bhikkhus, to the strenuously energetic, unarisen sloth and torpor does not arise, and arisen sloth and torpor is abandoned."

| | SLOTH & TORPOR. | INITIAL APPLICATION. |
|-------------------------------|---------------------------------------------|----------------------------------------------|
| General Characteristic. | Absence of zeal. Absence of ability to act. | The setting up or mounting of consciousness. |
| Inherent Functional Property. | Dissipation of energy. Enshrouding. | Impinging, striking all round. |
| Resultant Appearance. | Sinking down, sluggishness. | Guiding consciousness on to the object. |
| Concurrent Footing. | Improper attention. | - |

¹⁷⁰ A. Nivaraṇappahānavagga, see also G.S. vol. 1, pp. 2/3.

ABHIDHAMMATTHASAṄGAHA Talk No. 8 (Part 2).

422. The fourth of the five hindrances hostile to the development of skilful states Characteristic of the Plane of Form, consists of two qualities which, like “sloth and torpor,” show similarities in their adverse effect on concentration. These are DISTRACTION (*uddhacca*) and REMORSE (*kukkucca*), which in practical terms are inhibited by the fourth jhānaṅga, mental PLEASURE (*sukha*)—here the text uses *sukha* in the sense of *somanassa*.

423. The first of these obstructions, “distraction,” is the characteristic aspect of the second of the two unskilful integral states rooted in INTENSE DULLNESS AND DELUSION (*momuha*), referred to in verse 6 of Abhidhammatthasaṅgaha. As such, therefore, this hindrance is representative of one of the many forms in which the activity of IGNORANCE (*avijjā*) is apparent. “Distraction¹⁷¹” is thus the mental concomitant and hindrance promoting mental disquiet and turmoil, which, in conjunction with its dull, deluded root, makes it difficult for consciousness to grasp properly the single object with which it is attempting to engage. Of “distraction” the Commentary says it is like a four-sided stone, which when tumbling down a hill bumps down stage by stage as it alights on each of its consecutive faces. Similarly, consciousness, in not being stabilized, is unable to maintain consecutive concentration on the object to which its attention should be directed.

424. The second component of this dual hindrance, REMORSE (*kukkucca*), bears a resemblance to “distraction,” but for a quite different reason. Remorse, in terms of root, is dominantly an aspect of HATRED (*paṭigha*), and occurs, as is appropriate, in the two hateful states referred to in verse 5 of Abhidhammatthasaṅgaha. As remorse, its hateful nature is represented not, as in the case of ILLWILL (*byāpādā*), by antagonism or dislike for another being, but in self-anger in respect of things it has done or has not done. For this reason there comes about a worried state of mind, which because of its obsessive mental self-castigation and remorse regarding some thought or action already performed, cannot readily turn attention to the object of concentration.

425. In this sense, therefore, “distraction” and “remorse,” though dominated by different unskilful roots, are similar inasmuch as both are tumultuous and disturbing to the arising of stable conscious states, and are thus inimical to the skilful one-pointed directing of consciousness—essential to the development of the sublime states.

426. The four denotations of *uddhacca*, “distraction,” were given in connection with dull, deluded states,¹⁷² but are now summarized as follows: the General Characteristic of “distraction” is disquietude; its Inherent Functional Property, unsteadiness; its Resultant Appearance, turmoil; and its Concurrent Footing, improper attention to mental disquiet.

427. The Commentarial denotations of *kukkucca* are as follows:¹⁷³ “Remorse is its General Characteristic; bewailing in respect of actions done and not done, its Inherent Functional Property; contrition, its Resultant Appearance; actions done and not done, its Concurrent Footing. It should be looked upon as a state of slavery.”

428. In considering the inhibition of these obstacles, it is helpful to notice the connection the arising of their inhibitor, “mental pleasure,” has with the abstaining from bad states as a whole. As mentioned earlier, the development of sublime states necessitates a bond between the

¹⁷¹ See pars. 164-166.

¹⁷² See par. 165.

¹⁷³ See also Exp. p. 343 & Ppn. p. 532. Also earlier mention above, par. 375.

practice of moral behaviour and mental development. The outcome of such a bond is demonstrated on numerous occasions throughout the Piṭakas,¹⁷⁴ where in stating how abstention from evil is the characteristic mark of moral behaviour, it shows how such behaviour affords no basis for the arising of contrition or remorse, and how in the absence of these there is gladness, zest, calmness, and ability for action.

429. Contrasting this calmness and ability for action with the disquiet, turmoil and bewailing characteristic of "distraction and remorse," it is significant to find that calmness is itself the Concurrent Footing for "mental pleasure;" i.e., the mental pleasure which is the natural concomitant where there exists a proper bond between the practice of moral behaviour and mental development jointly directed towards the cultivation of Mahāggata states.

430. Thus it is that the Commentarial denotations of "mental pleasure" are not only those in respect of feeling as a whole, but in its capacity as a constituent of jhāna are additionally stated thus:¹⁷⁵ "Ease is the General Characteristic of (mental) pleasure; the augmenting of associated (states), its Inherent Functional Property; raising up (i.e., the promoting and exalting of associated states), its Resultant Appearance." "... calmness is its Concurrent Footing."

431. From this it is clear that the disquiet and remorse characteristic of uddhacca/kukkucca, cannot occur in the presence of the ease characteristic of "mental pleasure." Moreover, inasmuch as "mental pleasure" augments, develops and raises up calm, stabilizing associated qualities, the unsteadiness and bewailing inherent in "distraction and remorse" is put on one side; as also is the turmoil and contrition of their Resultant Appearance. Where there exists "mental pleasure," having as its Concurrent Footing, calmness, consequent upon abstention and moral behaviour, there cannot be present the improper attention to mental disquiet which is the Concurrent Footing for "distraction;" neither can there be the remorse consequent upon actions done or not done. Therefore it is said, "The hindrance of 'distraction and remorse' is inhibited by 'mental pleasure.'"

| | DISTRACTION & REMORSE | MENTAL PLEASURE |
|-------------------------------|-------------------------------------------------------------------|----------------------------------|
| General Characteristic. | Disquietude. Remorse. | Mental ease. |
| Inherent Functional Property. | Unsteadiness. Bewailing. | Augmenting associated states. |
| Resultant Appearance. | Turmoil. Contrition. | Raising up, exalting, promoting. |
| Concurrent Footing. | Improper attention to mental disquiet. Actions done and not done. | Calmness. |

432. The fifth hindrance is DOUBT (*vicikicchā*). "Doubt" is inhibited not, as with "sloth and torpor," by the "initial application" of consciousness, but by its SUSTAINED APPLICATION (*vicāra*). "Doubt," as a hindrance, is the mental concomitant which is operative in the first of the two dull, deluded states enumerated in verse 6 of Abhidhammatthasaṅgaha.¹⁷⁶ As with

¹⁷⁴ Notably A., "The Tens"—Sutta No. 1: G.S., vol. 5, p. 1f; Petakopadesa, C.S. edn., p. 254; Piṭaka Disclosure, p. 175.

¹⁷⁵ See Exp. p. 154 ff. & p. 145 f.

¹⁷⁶ See also par. 160 ff, above.

distraction, it represents the direct influence of IGNORANCE (*avijjā*); even though ignorance itself is sometimes included separately as a sixth hindrance.

433. In summary form the four denotations of “doubt” show a General Characteristic of fluctuation; an Inherent Functional Property of wavering; a Resultant Appearance of absence of certainty; and a Concurrent Footing of improper attention. Coupled with this the Commentary, in its simile of the stones rolling down a hill, contrasts “distraction” with “doubt” by saying that while “distraction,” like the four-sided stone, occasionally grasps its single object; “doubt,” because of the confusion of its many opinions, fails to grasp any one of them, and thus like a round stone rolls down the hill without stopping. From this it is clearly evident that doubt is a direct hindrance to concentration, and therefore to the cultivation of Mahāggata states.

434. If a condition exists whereby a diversity of objects or views precludes stability and one-pointedness of consciousness, it would at first sight be reasonable to suppose that the constant picking up of the object by “initial application” of consciousness would, to some extent, contribute to overcoming “doubt;” for by inhibiting “sloth and torpor” some strength and energy is present and consciousness is not then drooping, as the Commentary says:¹⁷⁷ “... like a bat hanging in a tree.” This is indeed so, but it represents only a preliminary step in that it is merely the initial hooking on to the object by consciousness. “Doubt,” on the other hand, is overcome only if perplexity regarding the object is dispelled. This can occur only where consciousness proceeds beyond the stage of “initial application” to that of exploring, surveying and reconnoitring the one object it is supposed to be considering, instead of being held back by inherent uncertainty.

435. This proceeding beyond “initial application” means the exerting of stronger effort in the form of more prolonged activity of consciousness in respect of its object. Such a condition is known as SUSTAINED APPLICATION (*vicāra*), the Commentarial denotations of which are as follows:¹⁷⁸ “This (sustained application) has constant surveying (lit. constant stroking) of the object as General Characteristic. In this connection (i.e. in constant surveying) its Inherent Functional Property is the application of conascent states; its Resultant Appearance is the continuity (i.e. uninterruptedness) of consciousness (in that surveying).”

436. From this it is apparent that the mental fluctuation characteristic of “doubt” is put on one side by the constant and determined way in which consciousness pursues the exploration and survey of its object. The wavering, which is inherently functional to “doubt,” is weakened and dispelled by the functional property of “sustained application” which gathers together and applies the appropriate mental concomitants to the thorough surveying of the object. Moreover, the absence of certainty which is the Resultant Appearance of “doubt,” disappears under the uninterrupted attention, or continuity, which “sustained application” of consciousness pays to its object. Finally, the improper attention to a diversity of views and objects, which is the very basis or Concurrent Footing of “doubt,” cannot be present where consciousness is concerned only with wise and skilful attention to its object. Thus it is said, “The hindrance of ‘doubt’ is inhibited by the ‘sustained application’ of consciousness.”

| | DOUBT | SUSTAINED APPLICATION |
|-------------------------------|--------------|----------------------------|
| General Characteristic. | Fluctuation. | Constant surveying. |
| Inherent Functional Property. | Wavering. | Applying conascent states. |

¹⁷⁷ Exp. p. 484.

¹⁷⁸ See also Exp. p. 152 & Ppn. p. 148.

| | | |
|-----------------------|---------------------|------------------------------|
| Resultant Appearance. | Uncertainty. | Continuity of consciousness. |
| Concurrent Footing. | Improper attention. | - |

437. Having compared the denotations of the five hindrances with those of the jhānaṅgas by which each is inhibited, it is apparent that where effort is to be directed to the strengthening of good, skilful Kāmāvacara integral states as preliminary to the attainment and cultivation of Mahāggata states, the process involved is in no sense a haphazard one. As Abhidhamma analysis shows, “wish for sense pleasure” is both greed and ignorance; “illwill” is both hatred and ignorance; “sloth and torpor,” as the enemy of effort, is an associate of ignorance; “distraction” is an aspect of ignorance; “remorse,” as self-anger, is hatred and ignorance; and “doubt” is ignorance also.

438. From this it is evident that where the practice of mental development is undertaken, the battle lies in overcoming IGNORANCE (*avijjā*) and CRAVING (*tanhā*) as they are manifest in the three bad roots of greed, hatred and dullness and delusion. Not only do these three appear in their direct and active sense, as thought, speech and bodily action associated with the twelve bad integral states, but in their far more subtle form as an inherent tendency to the arising of further bad states, and of forming a blockage, or hindrance, to the arising of good states. It is for this reason that the cultivation of moral practice is of such particular and technical importance to the practice of mental development, whether it be directed towards the ultimate goal of penetrative insight or to the cultivation of Mahāggata states as an aid to the achievement of that penetration by the generation of calm, stability and concentration.

439 It was indicated earlier that the practice of mental development, directed specifically to the accomplishment of sublime integral states, depends initially upon the intentional strengthening of skilful Kāmāvacara states to a point where their degree of perfection has reached a very high level, due to the gradual promoting to a position of virtual dominance the five mental concomitants: “initial application,” “sustained application,” “zest,” “mental pleasure” and “one-pointedness.” When, by means of practice, a condition has been reached whereby the five hindrances have been balanced out by these mental concomitants, a transition from Kāmāvacara states to Mahāggata states can, with suitable training and practice, be successfully effected. The modifications which take place in the courses of conscious process at that stage are not pursued here as they are explained at some length in chapter 4 of Abhidhammatthasaṅgaha; however, since the text of this present chapter illustrates characteristic structural differences between the five basic forms of the integral states involved, some explanation is necessary.

440. When the transition from Kāmāvacara to Mahāggata is made by causing to arise the first category of integral consciousness Characteristic of the Plane of Form, the conscious state concerned is known as the first rūpa-jhāna. This is a condition where the entire five constituents of jhāna, i.e., the same group of five mental concomitants just mentioned, operate from a position of absolute dominance; and where, in consequence, the five hindrances are held in complete abeyance and do not conflict with the existence either of that or any succeeding jhāna. Nevertheless, this first jhāna does not represent a condition of absolute perfection of concentration, because repeated “initial application,” or the remounting of consciousness on to its object, is still a necessary feature in order to maintain stability of concentration against the falling away of effort. When, and only when, that “initial application” ceases to be essential to the maintenance of effort, can it be said that a degree of mastery has been achieved. It also indicates that the other four constituents are correspondingly strengthened. When such a stage is reached, “initial application” of consciousness ceases to be helpful where further progress is to

be made, for concentration has become that degree more stable and effort equivalently stronger. With training, therefore, “initial application” can be put on one side.

441. At the time when “initial application” is thus terminated, the category of jhāna consciousness which by practice is then caused to arise, cannot any longer be classified as first rūpa-jhāna because of the termination of that “initial application.” However, since as a new class of integral state it inaugurates a higher degree of refinement and stability of consciousness, whereby it is maintained by the dominance of a fourfold structure of constituents of jhāna instead of five, it is categorized as the second rūpa-jhāna.

442. Even so, with these four dominant constituents, i.e., “sustained application,” “zest,” “mental pleasure” and “one-pointedness,” it cannot be said that the limit of refinement and concentration has yet been reached. Neither can it be said that mastery of that second jhāna has really been accomplished until such time as the constant exploring and surveying of the object of concentration, by “sustained application” of consciousness, ceases to be of further service if that second jhāna is to be surpassed. When, therefore, the stage has been reached where, with effort equivalently stronger, concentration has increased in stability, and where exploring and surveying cease to be of further service, “sustained application” is by training put on one side.

443. As in the instance of “initial application” and the first rūpa-jhāna, so also, with the termination of “sustained application,” further development cannot be classified as second jhāna. Consequently, where with training and practice there is inaugurated an even more refined, tranquil and concentrated level of integral consciousness, devoid of “initial application” and “sustained application,” yet maintained by the strength and dominance of only three constituents of jhāna, i.e., “Zest,” “mental pleasure” and “one-pointedness,” such a state is referred to as third rūpa-jhāna.

444. As with the preceding jhānas, this higher level of attainment still does not represent the limit of possible refinement and concentration. When, therefore, with intensified effort balanced by concentration, mastery of the third jhāna is achieved, the “zest” which was essential to the attainment and maintenance of the first, second and third jhānas, has no further function to perform if more advanced integral states are to be cultivated. Consequently, where it is intended that such further effort should be made, and a condition desireless of zest has been achieved, “zest” is put on one side.

445. With “zest” thus terminated, and with effort strengthened to a still higher degree, there is now scope for further development to a level of concentration of even greater intensity than that of the third jhāna. Thus, with training and practice guarded by strong mindfulness, a higher more refined category of integral consciousness is inaugurated wherein only two constituents of jhāna are dominant, these being “mental pleasure” and “one-pointedness.” Where under such very close control this combination is the characteristic structure, the integral conscious state is known as the fourth rūpa-jhāna.

446. At this stage the degree of concentration achieved has reached almost the limit of possibility, its culmination being marred only by the disturbing effect of the feeling of mental pleasure with which it is associated. However, as no integral conscious state can arise without the presence of FEELING (*vedanā*), it is necessary to recognize that while that feeling is yet pleasurable, no progress can be made to the final phase of rūpa-jhāna. When, therefore, mastery of this fourth jhāna has been achieved, further training is so directed that “mental pleasure” is abandoned and put on one side.

447. With “mental pleasure” thus terminated, the feeling associated with “one-pointedness” is now “neither-painful-nor-pleasant”; it is, therefore, neutral feeling. However, although still

representing the word *upekkhā*,¹⁷⁹ neutral is in these circumstances more usually translated as “equanimity,” it being a more appropriate term where used in connection with the advanced categories of integral states.

448. This final stage in the development of concentration on an object classified initially as MATERIAL (*rūpa*), has as its two dominant constituents of *jhāna*, “equanimity” and “one-pointedness.” Such *jhāna* has reached the level of attainment in concentration spoken of in *Vibhaṅga* as¹⁸⁰ “Purity of mindfulness caused by equanimity,” of which it continues to speak in the following terms:

“Therein what is equanimity? That which is equanimity, having equanimity, supreme equanimity, state of balance of consciousness. This is called equanimity. Therein what is mindfulness? That which is mindful-ness, constant mindfulness (...)”¹⁸¹ right mindfulness. This is called mindfulness. This mindfulness, because of this equanimity, is unobstructed, very pure, and very clear. Therefore this is called ‘purity of mindfulness caused by equanimity.’”

This is called the fifth¹⁸² *rūpa-jhāna*.

449. It has been seen that in the very first *jhāna* the five hindrances are completely inhibited by the dominance of the five constituents of *jhāna*. The question may therefore be asked as to why the individual hindrances do not arise again as, with the occurrence of progressively higher *jhānas*, the appropriate constituents of *jhāna* are themselves put on one side. The solution to this problem lies not in the question of any rearing of hindrances, but in the cumulative effect on the strength and stability of successive *jhānas*, caused not only by the removal of the hindrances in the first instance but by the removal of a yet further series of obstacles. Thus, with the primary need for the inhibition of the five hindrances, only a very rough, coarse impediment is removed; with a consequent arising of the first *jhāna*. Beyond this point, however, the hindrances being already inhibited, remain so; it is the constituents of *jhāna* themselves which now represent the further series of impediments to progress. Consequently, with the putting on one side of “initial application” the overall strength and stability of the second *jhāna* is greater by the cumulative effect of the primary removal of the coarse impediment of the hindrances, to which is now added the secondary removal of the finer obstacle of “initial application.” This cumulative process proceeds up to the fifth *rūpa-jhāna*, where its own supreme strength, unity, tranquillity and stability is due not only to the primary removal of the hindrances, but to the successive putting on one side of the further impediments of “initial application,” “sustained application,” “zest” and “mental pleasure” of the intervening *jhānas*.

450. Thus it is that progress from the original skilful *Kāmāvacara* states up to the fifth *rūpa-jhāna*, represents not just the inhibition of the five hindrances but the inhibition of a progressive series of obstacles commencing with the hindrances and proceeding therefrom to the *jhānaṅgas* themselves.

¹⁷⁹ See par. 80 f.

¹⁸⁰ See B.o.A., par. 597.

¹⁸¹ See B.o.A., par. 220 for intermediate terms.

¹⁸² Reference to B.o.A., par. 598 will show the *jhānas* as fourfold instead of fivefold. There is no confusion here. *Visuddhimagga*, explaining, it says: “Thus, that which in the fourfold system is the second (*jhāna*), that (*jhāna*) when split into two (i.e., first dropping ‘initial application,’ then ‘sustained application’) is, in the fivefold system, the second, and the third. Those which (in the fourfold system) are third and fourth, (in the fivefold system) are fourth and fifth. The first is only ever the first.” See also Ppn., p. 176, par. 202; also Exp. pp. 239-243.

451. In the Buddha's Teaching, training in respect of jhāna is given great and constant consideration. Whether, with appropriate change of object, its achievement be turned to the attainment of PENETRATIVE INSIGHT BY WAY OF JHĀNA (*samatha*¹⁸³-*vipassanā*); whether, quite apart from jhāna, the strength and stability-gained from its prior practice be directed to SIMPLE or DRY PENETRATIVE INSIGHT (*sukkha-vipassanā*); or whether jhāna be directed specifically to rebirth in the Brahmaloaka; its practice, as MENTAL DEVELOPMENT OF CALM (*samatha-bhāvanā*), features very strongly indeed throughout the Piṭakas.

452. In completing that section of Mahāggata states which deals with the five rūpa-jhānas in their fifteenfold division, they are summarized as follows in verse 25 of Abhidhammatthasaṅgaha:

VERSE 25

PANCADHĀ-JHĀNA-BHEDENA
RŪPĀVACARA-MĀNASAM
PUNNA-PĀKA-KRIYĀ-BHEDA
TAM PANCADASADHĀ BHAVE

Meaning:

BY WAY OF DIVISION (*bhedena*) of JHĀNA (*jhāna*), MENTAL ACTIVITY (*manasa*) CHARACTERISTIC OF THE PLANE OF FORM (*Rūpāvacara*) is FIVEFOLD (*pañcadha*). BY REASON OF THE DIVISION (*bheda*) into MERITORIOUS (*punna*), RESULTANT (*pāka*), and INOPERATIVE (*kriya*), THAT (*tam*) CAN BECOME (*bhāve*) FIFTEENFOLD (*pañcadasadhā*).

That concludes the section dealing with consciousness Characteristic of the Plane of Form.

¹⁸³ Lit. calm

ABHIDHAMMATTHASAṄGAHA Talk No. 9 (Part 1).

453. When discussing integral states Characteristic of the Plane of Form it was indicated that upon attainment of fifth rūpa-jhāna, where feeling is complete equanimity, there exists a condition wherein one-pointedness of consciousness in respect of its object may be said to have reached a limit of stability and perfection. This being so, can it therefore also be said that in connection with the practice of jhāna there yet remains something more to be done?

454. The answer to this is yes; however, its accomplishment lies not in the enhancement of one-pointedness of consciousness beyond that already achieved, but in the cultivation of jhāna with an inherently higher level of refinement and detachment. This is made possible by putting on one side the material object basic to the arising of the rūpa-jhānas and replacing it by an appropriate series of very much finer non-material objects.

455. In this connection it is to be observed that although those five jhānas come into being by the concentration of consciousness on a purely mind-door object, they are nevertheless referred to as rūpa-jhānas, meaning literally material jhānas. The reason for this usage originates at the stage prior to the occurrence of the first rūpa-jhāna, where, in order to balance out the obstructive effects of the five hindrances, skilful Kāmāvacara states are steadily strengthened by concentrating strongly on a specifically chosen material object, such for example as one of a particular series of visible objects known as kasiṇa. Where, as a result of striving, a purely mental image—a conceptual counterpart—of the chosen material object is successfully developed and maintained, and where as the result of this the transition from Kāmāvacara states to Mahāggata states is effected, both the resulting jhāna and its carefully maintained mental object are, because of the materiality of their original object, referred to as material.

456. To one who has embarked fully upon the practice and discipline essential to the cultivation of Mahāggata states, and who, as the result of Right Effort, Right Mindfulness and Right Concentration has completely and properly mastered the five rūpa-jhānas, there nevertheless comes a stage when even the purity of mindfulness of the fifth jhāna is recognized as being relatively gross due to the inherent proximity of its mental object to the original material object instrumental to its arising. In consequence of this a method is sought by means of which the grossness of materiality may be put on one side by the substitution of an entirely different object, one much further removed from that materiality than is the derived mental image that is the object of the rūpa-jhānas.

457. In looking back and considering the original material object, it can readily be appreciated that as with all material substance it possesses the fundamental characteristic of extension; that is, it occupies physically a certain volume in space. Furthermore, it can similarly be recognized that when, after concentrating upon such a material object, a clear and purified mental representation or counterpart of it can be retained and concentrated upon as a new object, separate from yet as being a derivative of that original material object, it can, as seen with the mind's eye, nevertheless still be said to occupy an area in space. However, in order to fulfil the new requirements of a higher level of refinement and detachment, it is this mental representation that has to be dispensed with before the immediate proximity of materiality can be said to have been superseded.

458. The developing of this new phase of jhāna depends primarily on there being a real perception of the grossness of materiality in respect of the cultivation of more refined, detached conscious states. Such perception of grossness being present, one who has attained to and fully mastered the fifth rūpa-jhāna and is intent upon rising beyond the limitations of material based

jhāna proceeds, by training and practice, first to expand to the most suitable degree the conceptual counterpart of the original material object upon which the jhāna is based. Desirous then of surmounting the limitations imposed by that counterpart, he disregards it, and in its stead attends only to the space occupied by that now disregarded image. With adequate and careful training, not only can this condition be realized, but, further than that, the full awareness of the mentally expanded space is identified with the concept of the infinity of space.

459. When this stage has been attained to where consciousness has as its conceptual object “the infinity of space,” it can be said that the limitation imposed by JHĀNA CHARACTERISTIC OF THE PLANE OF FORM (*Rūpāvacara-jhāna*) has been surmounted by the cultivation of JHĀNA CHARACTERISTIC OF THE FORMLESS PLANE (*Arūpāvacara-jhāna*). Of this Vibhaṅga says:¹⁸⁴ “... having wholly passed beyond the perceptions of form by terminating the perceptions of (sense) impingement, by not attending to diversity of perceptions, (concentrating) thus, ‘infinite is space,’ he attains and dwells in the state of infinity of space.”

460.¹⁸⁵ Thus it is that where consciousness has as its conceptual object “the infinity of space,” the integral state so engaged is known as first *Arūpāvacara-jhāna*, i.e., first jhāna Characteristic of the Formless Plane.

461. Where the explicit aim is to cultivate conscious states of the highest possible degree of calm, purity, refinement and detachment from the worlds of sense, it is apparent that although integral states having “infinity of space” as their object are indeed aloof both from sense pleasure and from the taint of direct association with materiality, they do nevertheless stand in close proximity to states based in the first place on a material object. Consequent upon this, to one who has fully mastered the first *arūpa-jhāna*, and who recognizes the danger inherent in this proximity, the immediate purpose will be to cultivate an even more highly refined and calm state of consciousness whereby such danger is put at greater distance.

462. To make this possible a further change of object is necessary, for space is, in a sense, akin to the object which occupied it. By training and practice, therefore, the attention which in the first *arūpa-jhāna* is directed to concentrating on “infinity of space,” is terminated. Attention is then re-directed, not any longer to the “infinity of space” but to the former consciousness which “touched” that same space. Where this transition is achieved, awareness in respect of that former consciousness is then mentally expanded to the extent that it is identifiable with the concept of “infinity of consciousness.”

463. When this stage has been attained where consciousness has as its conceptual object “infinity of consciousness,” the limitation of first *arūpa-jhāna* has been surmounted by the cultivation of second *arūpa-jhāna*. Of this, Vibhaṅga says:¹⁸⁶ “... having wholly passed the state of infinity of space, (concentrating) thus, ‘infinite is consciousness,’ he attains and dwells in the state of infinity of consciousness ...”

464.¹⁸⁷ Thus it is that where consciousness has as its conceptual object “infinity of consciousness,” the integral state so engaged is known as second *arūpāvacara-jhāna*, i.e., second jhāna Characteristic of the Formless Plane.

465. This jhāna, based as it is on a much refined and detached object, besides possessing the characteristic concomitant qualities of equanimity and one-pointedness, maintains a mental

¹⁸⁴ See B.o.A. par. 508, and detailed analysis pars. 602-608 inc.

¹⁸⁵ See chart 12.

¹⁸⁶ See B.o.A. par. 508, and detailed analysis pars. 609-613 inc.

¹⁸⁷ See chart 12.

quietude and stability very near to the limit of perfection. In spite of this, though, to one who has gained complete mastery of the jhāna, there nevertheless remains the knowledge that the ultimate degree of tranquillity obtainable by way of Mahāggata states has not yet been reached. Moreover, it is also realized that while “infinity of consciousness,” with its close proximity to “infinity of space,” is still the object of concentration, further progress towards that tranquillity cannot be made. This being so, yet another change of object is necessary.

466. Concurrent with the transitions from fifth rūpa-jhāna to first arūpa-jhāna, and from thence to second arūpa-jhāna, it is apparent that there exists a direct relationship between the successive objects of concentration upon which these jhānas are based. This continuity of relationship applies likewise in respect of the remaining higher levels of Arūpāvacara-jhāna. Thus, in the transition from fifth rūpa-jhāna to first arūpa-jhāna the necessary change was from the conceptual counterpart of a material object to concentration on the space occupied by that image. In the transition from first arūpa-jhāna to second arūpa-jhāna the necessary change was from concentration on that space, expanded to infinity of space,” to concentration in respect of the previously existing consciousness that “touched” that “infinity of space.” In the present instance, where the transition to be made is from second to third arūpa-jhāna, this direct relationship between successive objects still applies, for here the necessary change consists in putting on one side concentration on “infinity of consciousness” and in its stead directing concentration to the nothingness, the emptiness, the solitariness that becomes apparent upon the withdrawal of that previous object.

467. When the stage has been reached where, by training and practice, consciousness has as its conceptual object “nothingness,” the limitation inherent in the second arūpa-jhāna has been surmounted by the cultivation of the third arūpa-jhāna. Of this, Vibhaṅga says:¹⁸⁸ “... having wholly passed the state of infinity of consciousness, (concentrating) thus, ‘there is nothing whatever,’ he attains and dwells in the state of nothingness”

468.¹⁸⁹ Thus it is that where consciousness has “nothingness” as its conceptual object, the integral state so engaged is known as third Arūpāvacara-jhāna, i.e., third jhāna Characteristic of the Formless Plane.

469. Before proceeding to the fourth and final jhāna Characteristic of the Formless Plane, it should here be emphasized that despite a certain superficial similarity the objects of the first and third arūpa-jhānas, “space” and “nothingness” respectively, should not be confused, they are in every way quite distinct from each other and are differently based. “Space,” the object of the first arūpa-jhāna, is the direct outcome of the removal of the materiality object. “Nothingness,” the object of the third arūpa-jhāna, is the direct outcome of the removal of the consciousness object.

470. In the three arūpa-jhānas so far discussed it is apparent that in cultivating their attainment the purpose has been not only to reach conditions of steadily increasing stability, calm and detachment, but also, in the existing state of complete equanimity and one-pointedness, to carry to the limit the refinement of consciousness and its associated mental concomitants by directing attention to objects ever further removed from the grossness of materiality, and even from the diminishing degrees of grossness in successive non-material objects.

¹⁸⁸ See B.o.A. par. 508, and detailed analysis pars. 614-618 inc.

¹⁸⁹ See chart 12.

471. Here the question may be raised as to whether there can possibly be any further progress beyond the point where the object of concentration is the “nothingness” perceivable upon the withdrawal of the former conscious state as object. In this connection progress lies in consolidation rather than in any desire to surmount.

472. Where “nothingness” is the object, it is recognizable that virtually undisturbed peacefulness and calm is the all pervading quality. However, that peacefulness and calm does not exist in the “nothingness” itself but in the integral conscious state that fixes upon “nothingness” as its object; consequently, consolidation of that peacefulness cannot be achieved by further concentration on “nothingness,” but only by putting that “nothingness” on one side and in its stead directing attention to a new object. This new object, pervaded as it is by the peacefulness inherent in its nature, consists of a conceptual representation of the consciousness and mental concomitants that constituted the actual attainment of the state of “nothingness.” But into what category does the integral conscious state fall which is based on this new object?

473. In discussing Mahāggata states as a whole, the terms “developing” and “refining” have frequently been made use of. In the way in which they occur in connection with the perfecting of such states their meanings are, however, virtually the same; for in the striving entailed in mastering fully one category of jhāna, and progressing from thence to a higher state, that which has been developed has likewise been refined. Here, refined is used in the sense of being made finer, rather as the point of a needle is finer than the point of a stake sharpened for thrusting into the ground. In these two instances, although both are sharp, the difference between them is considerable, the sharpness being relative, for whereas the needle on account of its fineness of point is quite unsuited to thrusting aside a mass of coarse, rough earth, the sharpened stake is equally unsuited to passing between fine threads in the execution of delicate needlework. Thus, although both are said to be sharp, they fall into different categories.

474. In a comparable way can it also be said of integral conscious states. Those which achieve first rūpa-jhāna, although much finer and more acute than Kāmāvacara states in that they can effectively keep at bay the five hindrances, are nevertheless far less sharp and probing than is the consciousness that experiences fifth rūpa-jhāna; for this latter state, by reason of the preceding successive stages of developing, sharpening and becoming finer, is virtually uninfluenced by the impingement of sense stimuli. In like manner is it so with the further development that takes place from the fifth rūpa-jhāna to the first arūpa-jhāna, and onward through the second and third to this new integral state, the fourth arūpa-jhāna. With each stage the probing ability of consciousness becomes finer and more subtle, and at the same time more remote from and less adapted to the perceptions of the worlds of sense.

475. Thus it is that in this final stage, the fourth arūpa-jhāna, unity of consciousness and its associated mental concomitants becomes so fine, so acute, so sublimated in its cognizance of peacefulness and calm, that feeling, perception, contact, etc., and awareness in respect of all conditions other than the peacefulness and calm inherent in its object, are as though they do not exist. Consequent upon this most sublime condition it is necessary to say when describing the integral state that has as its object the four aggregates, or groupings of mental qualities, that constituted attainment of the state of “nothingness,” that whereas in respect of that one object it is abundantly clear that perception of the most refined, delicate and acute order is present, there is in respect of all other objects no perception whatsoever. For this twofold and discriminatory reason this type of integral consciousness is described in a twofold manner, as being both perceptive and non-perceptive.

476. When, therefore, attainment of jhāna based on this one particular object is achieved it is called THE STATE OF NEITHER PERCEPTION NOR NON-PERCEPTION

(*nevasaññānāsaññāyatana*). Of this, Vibhaṅga says:¹⁹⁰ "... having wholly passed the state of nothingness he attains and dwells in the state of neither perception nor non-perception."

477.¹⁹¹ Thus it is that where consciousness takes as its conceptual object the four aggregates constituting attainment of the state of "nothingness," the integral state so engaged is known as fourth Arūpāvacara-jhāna, i.e., the fourth jhāna Characteristic of the Formless Plane.

478.¹⁹² The four arūpa-jhānas, based as they are on four successive individual but derivatively related non-material objects, represent the most highly evolved aspects of mental development classifiable as MUNDANE (*lokiya*). As integral conscious states they do, however, maintain a fundamental relationship with the rūpa-jhānas, in that their constituent structure in terms of consciousness and mental concomitants is in every way the same as that of the fifth rūpa-jhāna. The arūpa-jhānas can indeed be said to be an extension of that fifth jhāna, differing from it only in terms of their increasing degrees of refinement, developed by way of concentration on non-material objects.¹⁹³ As to the distinctions between the arūpa-jhānas themselves, this lies only in their respective levels of sublimity. This the Commentary¹⁹⁴ explains by the simile of a woman possessing four dresses made to a single pattern, but of materials of different weights and texture; one being of heavy texture and fourfold weight, one of medium texture of threefold weight, one soft and of double weight, and one very delicate of single weight. Of these four dresses of identical pattern, their excellence is judged in proportion to their softness and delicacy. So is it with the arūpa-jhānas; although identical in structure, their excellence is judged by the progressive refinement of their constituent qualities. As to the constituents of jhāna, which by their successive terminations play so important a role in the rūpa-jhānas, these in arūpa-jhānas are EQUANIMITY (*upekkhā*) and ONE-POINTEDNESS (*ekaggatā*), exactly as in the fifth rūpa-jhāna.

479.¹⁹⁵ As with BEAUTIFUL (*sobhanā*) states Characteristic of the Planes of SENSE DESIRE (*kāma*) and FORM (*rūpa*), beautiful states classified as Arūpāvacara are divided into three categories, viz., good (productive), resultant and inoperative. In consequence of this, where there has been achievement by those who have not attained to the final deliverance of arahantship, the outcome of good (productive) states is resultant states. Where such productive states have occurred in appropriate circumstances, their resultants cause rebirth to take place in the plane of existence which is their natural habitat, in this case the Arūpāvacara bhūmi. From this it is apparent that as in the cases of Kāmāvacara and Rūpāvacara, the term Arūpāvacara is twofold in meaning in that it signifies not only a category of integral conscious states, in this instance twelve, but also the plane of existence which is the natural habitat of those states.¹⁹⁶

VERSE 26

480.¹⁹⁷ ĀKĀSĀNANCĀYATANA-KUSALA-CITTAM
VIÑÑĀNANCĀYATANA-KUSALA-CITTAM
AKINCANNAYATANA-KUSALA-CITTAM

¹⁹⁰ See B.o.A. par. 508, and detailed analysis pars. 619-622 inc.

¹⁹¹ See chart 12.

¹⁹² See chart 13.

¹⁹³ In the case of the fourfold system of rūpa-jhāna the arūpa-jhānas represent an extension of the fourth rūpa-jhāna. See also second note, par. 448.

¹⁹⁴ See Exp. p. 281, also Ppn. p. 369.

¹⁹⁵ See chart 12.

¹⁹⁶ Cp. pars. 46, 314 f. & 380 f.

¹⁹⁷ See chart 12.

NEVASANNĀ-NĀSANNAYATANA-KUSALA-CITTAN CE TI
IMĀNI CATTĀRI PI ARUPAVACARA KUSALA-CITTĀNI NĀMA

Meaning:

IT IS THUS (*iti*): GOOD productive integral CONSCIOUSNESS (*kusala-citta*) of the STATE OF INFINITY OF SPACE (*akāsa + ānañca* [fr. *Ananta*] + *ayatana*¹⁹⁸), Good (productive) integral consciousness of the STATE OF INFINITY OF CONSCIOUSNESS (*viññāna + ānañca + ayatana*), Good (productive) integral consciousness of the STATE OF NOTHINGNESS (*ākīñcañña* [fr. *Akiñcana*] + *āyatana*), AND (*ca*) Good (productive) integral consciousness of the STATE OF NEITHER PERCEPTION NOR NON-PERCEPTION (*na + eva + sañña + na + asanna + ayatana*). THESE (*imāni*) FOUR TOGETHER (*cattari pi*) ARE KNOWN AS (*nāma*) GOOD (*kusala*) productive integral CONSCIOUS STATES (*cittāni*) CHARACTERISTIC OF THE-FORMLESS PLANE (*arūpāvacara*).

Here this term represents not only the state or condition described as “neither perceptive nor non-perceptive,” but also the object or basis for the arising of that category of consciousness and its abode or dwelling place while arisen.

VERSE 27

481. AKASANANCAYATANA-VIPĀKA-CITTAM
VIÑÑĀNANCAYATANA-VIPĀKA-CITTAM
AKINCANNAYATANA-VIPĀKA-CITTAM
NEVASANNĀ-NĀSANNĀYATANA-VIPĀKA-CITTAN CE TI
IMĀNI CATTĀRI PI ARRŪPĀVACARA VIPĀKA-CITTĀNI NĀMA

Meaning:

It is thus: RESULTANT (*vipāka*) integral consciousness of the state of infinity of space, Resultant integral consciousness of the state of infinity of consciousness, Resultant integral consciousness of the state of nothingness, and Resultant integral consciousness of the state of neither perception nor non-perception.

These four together are known as RESULTANT (*vipāka*) integral conscious states Characteristic of the Formless Plane.

VERSE 28

482. AKASANANCAYATANA-KIRIYA-CITTAM
VIÑÑĀNANCAYATANA-KIRIYA-CITTAM
AKINCANNAYATANA-KIRIYA-CITTAM
NEVASANNA-NĀSANNAYATANA-KIRIYA-CITTAN CE TI
IMĀNI CATTĀRĪ PI ARŪPĀVACARA KIRIYA-CITTĀNI NĀMA

Meaning:

It is thus: INOPERATIVE (*kiriya*) integral consciousness of the state of infinity of space, Inoperative integral consciousness of the state of infinity of consciousness, Inoperative integral consciousness of the state of nothingness, and Inoperative integral consciousness of the state of neither perception nor non-perception.

These four together are known as INOPERATIVE (*kiriya*) integral conscious states Characteristic of the Formless Plane.

¹⁹⁸ AYATANA = STATE.

VERSE 29

483. ICCEVAM SABBATHĀ PI DVĀDASA ARŪPAVACARA-KUSALA-VIPĀKA-KIRIYA-CITTĀNI SAMATTĀNI

Meaning:

THUS (*iccevam*) FROM EVERY ASPECT (*sabbathā-pi*) the TWELVE (*dvā dasa*) GOOD (*kusala*) productive, RESULTANT (*vipāka*) and INOPERATIVE (*kiriya*) integral CONSCIOUS STATES (*cittāni*) CHARACTERISTIC OF THE FORMLESS PLANE (*Arūpāvacara*) are FULLY COMPLETED (*samattāni*).

As the concluding passage of the section dealing with the entirety of Mahāggata integral states, verse 30 of Abhidhammatthasaṅgaha consists of a mnemonic stanza summarizing the twelvefold division of the four Arūpāvacara jhānas.

VERSE 30

484. ALAMBANAPPABHEDENA
CATUDH ĀRUPPA MANASAM
PUNNA-PĀKA-KRIYA-BHEDĀ
PUNA DVĀDASADHĀ THITAM

Meaning:

BY WAY OF VARIETY (*pabhedena*) of OBJECT (*ālambana*), MENTAL ACTIVITY (*mānasa*) in respect of FORMLESSNESS (*āruppa*) is FOURFOLD (*catudhā*), FURTHERMORE (*puna*) BY REASON OF THE DIVISION (*bhedā*) into MERITORIOUS (*punna*) RESULTANT (*pāka*) and INOPERATIVE (*kiriya*) it is ESTABLISHED (*thitam*) as TWELVEFOLD (*dvādasadhā*).

485. At the commencement of the section dealing with Mahāggata states it was indicated that their cultivation is not mandatory to the attainment of penetrative insight;¹⁹⁹ however, the ability to concentrate gained from the training and practice associated with their development is nevertheless of inestimable value when directed to achieving that insight. In this connection Abhidhamma analysis demonstrates the positive relationship existing between concentration and insight, for not only is PENETRATIVE INSIGHT (*vipassanā*) shown to be synonymous with WISDOM or UNDERSTANDING (*paññā*), but, in addition to that, CONCENTRATION (*samādhi*) is specified as the Concurrent Footing of *paññā*.²⁰⁰ From this it is clear that where penetrative insight is to be achieved, concentration, i.e., RIGHT CONCENTRATION (*sammā-samādhi*) must be exercised.

486. Teaching the importance of concentration the Buddha says:²⁰¹ "... Bhikkhus, develop concentration. Bhikkhus, the concentrating bhikkhu comprehends in accordance with reality. And what does he comprehend? He comprehends thus; in accordance with reality, this is suffering. He comprehends thus; in accordance with reality, this is the cause of suffering. He comprehends thus; in accordance with reality, this is the cessation of suffering. He comprehends thus; in accordance with reality, this is the way leading to the cessation of suffering. Bhikkhus, develop concentration. Bhikkhus, the concentrating bhikkhu comprehends in accordance with reality. That concludes the section dealing with consciousness Characteristic of the Formless Plane.

¹⁹⁹ See par. 395.

²⁰⁰ See par. 326.

²⁰¹ See Samādhisutta, Saccasaṃyutta 1; also K.S. vol. 5 p. 352.

ABHIDHAMMATTHASAṄGAHA Talk No 9 (Part 2)

487. In the second of the two introductory stanzas to Abhidhammatthasaṅgaha mention is made of the four categories of ULTIMATES (*paramattha-dhamma*), consciousness, mental concomitants, material qualities, and Nibbāna.²⁰² In verse 3 it says concerning the first of these,²⁰³ "In that connection consciousness is first and has four divisions, thus: consciousness CHARACTERISTIC OF THE PLANE OF SENSE DESIRE (*Kāmāvacara*), CHARACTERISTIC OF THE PLANE OF FORM (*Rūpāvacara*), CHARACTERISTIC OF THE FORMLESS PLANE (*Arūpāvacara*), and SUPRAMUNDANE (*Lokuttara*)."

488. In considering these two introductory statements it will be appreciated that consciousness has so far been dealt with in respect of only three of its categories, i.e., Kāmāvacara, Rūpāvacara and Arūpāvacara, Mental concomitants have been mentioned only in so far as they are relevant to this first chapter, and material qualities not at all, chapter six of Abhidhammatthasaṅgaha being devoted almost entirely to these latter. The remaining ultimate is thus Nibbāna, and the remaining category of consciousness is that known as Supramundane. From this a first question can be framed thus: in what relationship do these two stand to each other?

489. As item ten of the threefold categories, the Tika Mātikā of Dhammasaṅgani, the first book of the Abhidhammapiṭaka, there is the following triplet:

- 1) "STATES CUMULATIVE (*ācayaḡāmino dhammā*) of continuing rebirth and death.
- 2) "STATES DISPERSIVE (*apacayaḡāmino dhammā*) of continuing rebirth and death.
- 3) "STATES NEITHER CUMULATIVE NOR DISPERSIVE (*nevācayaḡāminapacaya-ḡāmino dhammā*) of continuing rebirth and death."

490. The first of these categories comprises the entire range of good and bad (productive) integral states characteristic of the three mundane planes, i.e., Kāmāvacara, Rūpāvacara and Arūpāvacara. As active conscious states, all are described as cumulative of continuing rebirth and death by reason of not being free from the defiling effects of sense pleasure, attachment to existence, views and ignorance. The third category includes the resultants of all good and bad (productive) integral states, irrespective of plane, together with the inoperative states of the three mundane planes. Resultants are clearly neither cumulative nor dispersive of continuing rebirth and death, being but the outcome of past productive action and therefore not directly productive in any further sense. Inoperative states are by definition neither cumulative nor dispersive, representing solely the activity of those wholly free from rebirth tendency, the arahantas.

491. Bearing in mind that these first and third categories constitute the entirety of integral states of the three mundane planes, a second question can be framed thus: what conscious states constitute the second category described as "dispersive of continuing rebirth and death?"

492. At this point the first and second questions can be brought together for clarification in the form of a definition, thus: integral conscious states classified as SUPRAMUNDANE (*lokuttara*) are so named because they experience the UNCONDITIONED ELEMENT (*asaṅkhata-dhātu*), Nibbāna, as their only object. Because such states make an end to the several qualities fettering beings to the rounds of existence, they are likewise classified as "states dispersive of continuing rebirth and death." From this it is apparent that states taking Nibbāna as object are those which at the same time destroy the fetters causative of continuing rebirth and death; what

²⁰² See par. 40.

²⁰³ See par. 44.

is it, therefore, which leads up to the point at which Nibbāna becomes the object of consciousness, and what are the fetters which are thereby destroyed? But first, in what manner does one attempt to describe Nibbāna?

493. As the fourth and final category of Ultimates the several modes by which it is classifiable in comparative terms are given in the concluding section of chapter six of Abhidhammatthasaṅgaha. Even so, such classifications do not, and indeed cannot constitute a direct description of Nibbāna, for to attempt by means of mundane expression to describe that which is supramundane is clearly a contradiction of terms. In the present instance, as the basis upon which supramundane integral states come to be, Nibbāna is the object of which consciousness is fully aware at the time when, aloof from all sense pleasure and utterly freed from aspects of ignorance and craving manifesting as wrong views and doubts, it passes quite beyond the limitations of mundane knowledge and understanding. Having thus penetrated to the supramundane, insight and understanding, perceiving ultimate reality, thus come to know that which was previously unknown (i.e., the initial stage of penetrative understanding when Nibbāna is experienced for the first time: “I am knowing the unknown” = anannatannassāmi).

494. To consider now the question of what it is that leads to the point at which Nibbāna becomes the object of consciousness. In Visuddhimagga, the comprehensive treatise on the theory and practice of the Buddha’s Teaching, its author—Ven. Buddhaghosa—speaks of this as, “the soil in which understanding grows.” Here, in shortened form is the substance of what is said:²⁰⁴

“... how is understanding to be developed? It being such that the aggregates, bases, elements, controlling faculties, truths, dependent origination and so on, are the soil of understanding, with purity of moral practice and purity of consciousness as its root, and with five additional purities as its trunk; then accordingly an intimate knowledge of that soil gained by study and question, together with accomplishment of the two purities as root, enables the trunk to be developed by the further accomplishment of the remaining five purities.”

495. Here, understanding refers to the development of PENETRATIVE UNDERSTANDING (*vipassanā*). The AGGREGATES (*khandhā*) refer to the five groups of mental and material qualities constituting the so-called being. The twelve BASES (*ayatana*), the eighteen ELEMENTS (*dhātu*), and the twenty-two CONTROLLING FACULTIES (*indriya*) refer to particular and associated mental and material attributes variously operative in the existence and activity of beings. The TRUTHS (*sacca*) refer to the Four Noble Truths, i.e., of suffering, its cause, its cessation and the Noble Eight Constituent Path leading to that cessation. DEPENDENT ORIGINATION (*paṭiccasamuppāda*) refers here not only to the twelvefold series of reciprocal causes and results constituting the structural framework of the whole round of continuing rebirth and death, but also to the twenty-four CONDITIONING FACTORS (*paccaya*) which determine the ultimate operating relationships occurring between all states. Each of these subjects is considered individually at appropriate points in Abhidhammatthasaṅgaha, as also are very many other groupings covered by the phrase “and so on.”

496. Examination of these groupings shows that the necessary soil from which penetrative understanding can arise consists in forming a basis of mundane knowledge and understanding which grasps thoroughly and gains an absolute and coherent conviction of the ultimate nature of both MENTAL QUALITIES (*nāma*) and MATERIAL QUALITIES (*rūpa*), as exhibiting at all times their innate characteristics of IMPERMANENCE (*anicca*), UNSATISFACTORINESS (*dukkha*) and ABSENCE OF SOUL (*anattā*). Nevertheless, although the soil in which

²⁰⁴ For its original form see Ppn. p. 488 and P. Purity p. 514.

understanding is able to develop undoubtedly consists of a knowledge and mundane appreciation of the nature of aggregates and other properties, the feasibility of such development can be equated with the growth of plants. As plants need roots to make growth possible, so also for understanding to develop, the appropriate root is equally essential. In this case the soil of knowledge can be operative only in conjunction with a root comprising Purity of Moral Practice and Purity of Consciousness

497. Here, PURITY OF MORAL PRACTICE (*sīla visuddhi*) means the constantly perpetuated observance of morality of one who cleanses himself from the impurity of wrong moral behaviour in respect of bodily action and speech. This, in the case of a bhikkhu, represents the proper observance of the disciplinary rules of the Vinaya; for a lay person it is the conscientious practice, maintenance, and regeneration of the five moral precepts.

498. PURITY OF CONSCIOUSNESS (*citta visuddhi*) means the state achieved by cleansing oneself of the impurity of the hindrances by well developed continuity of consciousness, i.e., by CONCENTRATION (*samādhi*). In this connection the ultimate level of Purity of Consciousness is achieved either by the practice of jhāna succeeded by the attainment of supramundane states, where it is called samatha vipassanā, i.e., penetrative insight of calm; or by the attainment of supramundane states quite apart from the practise of jhāna where it is known as sukkha vipassanā, i.e., dry penetrative insight.

499. Considering now the entire group of seven Purities described in the shortened extract from Visuddhimagga as constituting the root and trunk of attainment; in what manner are they related to each other, and in what sequence do they occur? Their sequence and relationship is customarily stated in terms of samatha vipassanā; however, whether final attainment of supramundane penetrative insight is achieved by way of jhāna or quite without it, the totality of realization in terms of categories of Knowledge and grades of Purity remains the same. At this point only a bare minimum of detail is given of the transitional Knowledges and Purities, as the subject of vipassanā belongs properly to chapter nine of Abhidhammatthasaṅgaha.

500. Commencing with the establishment of the basis of PURITY OF MORAL PRACTICE (*sīla-visuddhi*), there is developed in conjunction with that the ability to concentrate the mind. This, in the case of the samatha vipassaka, means concentration to the extent of practising jhāna; however, for the sukkha vipassaka with appropriate ability to be one-pointed in thought, PURITY OF CONSCIOUSNESS (*citta-visuddhi*) is adequately established, thus the root exists whereby the remaining five Purities—the trunk—can grow. From the ability to concentrate is developed the realization that mental qualities and material qualities alone constitute the fundamentals of existence. Such realization, coupled with mundane insight into how those qualities are recognized and understood in terms of their appropriate denotations, i.e., GENERAL CHARACTERISTIC, INHERENT FUNCTIONAL PROPERTY, RESULTANT APPEARANCE and CONCURRENT FOOTING (*lakkhana, rasa, paccupatthāna, padatthāna*) is known as KNOWLEDGE OF THE DIVISIONS INTO MENTAL AND MATERIAL QUALITIES (*nāma-rūpa-pariccheda-nāna*). Here, and also with the examples that follow, the word “knowledge” is used in the sense meaning “mundane insight.” With the gaining of this insight, PURITY OF VIEW (*ditṭhi-visuddhi*) is established, as also is mundane insight into the first of the Four Noble Truths, i.e., THE TRUTH OF SUFFERING (*dukkha-sacca*).

501. By probing more deeply into mental and material qualities in the light of this Purity, observing in relationship to past, present and future the constant and inevitable changes that take place, there comes about a further stage of mundane insight known as KNOWLEDGE COMPREHENDING CAUSE AND EFFECT (*paccaya-pariggaha-nana*). By this Knowledge, doubt and uncertainty as to the relationship between cause and its outcome is overcome, thereby

establishing PURITY THAT CROSSES OVER UNCERTAINTY (*kaṅkha-vitarāṇa-visuddhi*). At the same time there arises mundane insight into the second Noble Truth, i.e., THE TRUTH OF THE CAUSE OF SUFFERING (*dukkha-samudaya-sacca*).

503. With uncertainty thus overcome, a deeper examination of all that has gone before makes evident the universal characteristics of IMPERMANENCE, SUFFERING or UNSATISFACTORINESS and ABSENCE OF SOUL (*anicca, dukkha, anattā*). To have become fully aware of these distinctive qualities constitutes KNOWLEDGE COMPREHENDING (*sammāsana-nāna*) the Three Characteristics; and with that comes insight, still mundane, into the manner in which states mental and material come to be and pass away. This represents the initial phase of a yet further degree of insight, i.e. KNOWLEDGE OF RISE AND FALL (*udayabbaya*²⁰⁵-*nāna*: first phase).

504. The realization of these Knowledges initiates a new Purity, for with them comes mundane insight into the fourth Noble Truth, i.e., THE TRUTH OF THE WAY LEADING TO THE CESSATION OF SUFFERING (*dukkha-nirodha-gāmini-paṭipadā-sacca*), thereby establishing without ambiguity the PURITY THAT DISCERNS THE CORRECT PATH AND THE INCORRECT PATH (*maggamagga*²⁰⁶-*nāna-dassana-visuddhi*). With this Purity thus established, probing into the several aspects of the rise and fall of states in terms of the Three Characteristics is pursued with unremitting effort. This is done because it is only by a complete recognition of the actual principles involved in the coming to be and passing away of states, that the true nature of impermanence, suffering, and absence of soul becomes properly apparent. With mundane insight into this, the final phase of KNOWLEDGE OF RISE AND FALL (*udayabbaya-nāna*, second phase) is completed and the way becomes open for the attainment of the remaining mundane Purity.

505. The realization of this Purity, which is the outcome of yet further attention directed to gaining insight into the Three Characteristics, consists initially of gaining eight further categories of mundane Insight Knowledges, which together constitute a series of stages leading directly from mundane understanding of conditioned existence dominated by those Three Characteristics, to a level of insight that has attained to absolute detachment and balance of mind in respect of that same conditioned existence: *saṅkhār upekkhā-nāna*.

506. These eight categories of insight are followed by a further Knowledge, one which although still mundane, and therefore compatible with those already achieved, represents nevertheless the absolute; culmination of mundane insight. However, because at such a level of attainment this mundane insight has also achieved a degree of understanding compatible with supramundane penetrative insight, it is known as KNOWLEDGE HAVING CONFORMITY (*anuloma-nāna*), i.e., conformity with both mundane and supra-mundane Knowledge. Regarded as a group, this ninefold series of Knowledges constitutes PURITY OF DISCERNMENT IN FOLLOWING THE COURSE (*paṭipadā-nāna-dassana-visuddhi*).

507. Attainment of the initial supramundane Path is now virtually automatic, for, as is shown in chapter four of Abhidhammatthasaṅgaha, the concluding series of Knowledges, together with attainment and its immediately succeeding resultants, consists of a series of adjacent instants of consciousness constituting the FULL AWARENESS (*javana*) phase of a particular course of the conscious process. However, immediately prior to PATH (*magga*) attainment there occurs a single transitional moment leading from the mundane to the supramundane. At this point, because there has already been full mundane insight into existence mental and material in terms

²⁰⁵ = udaya + vaya.

²⁰⁶ = magga + amagga.

of one or other of the Three Characteristics, there comes about true comprehension of the Four Noble Truths. This being so, the lineage of the worldling is permanently conquered by the supramundane lineage. The instant of consciousness which performs this function, and which takes Nibbāna as its object, is called KNOWLEDGE EVOLVING THE supramundane LINEAGE (*gotrabhū-nana*).

508. This important stage is followed immediately by the first moment of Path consciousness. It is this consciousness which experiences Nibbāna for the first time; it is known as PATH CONSCIOUSNESS OF INITIAL ENTRY INTO THE STREAM (*sota-patti-magga-citta*). This realization of the supramundane, together with its immediately succeeding instants of resultant consciousness, is called PURITY OF supramundane DISCERNMENT (*nāna-dassana-visuddhi*).²⁰⁷

509. This much condensed outline of the Purities and Knowledges leading to the point at which Nibbāna becomes the object of consciousness, raises the question as to the nature of the many factors inimical to that realization; it also involves an investigation into the stages through which realization passes, with the consequent weakening and abandoning of those factors.

510. In the section of Visuddhimagga entitled, "The Abandoning of States which are to be Abandoned," are described eighteen composite groups of undesirable qualities which are of necessity rejected and abandoned in the course of attaining the successive Paths of supramundane realization. It also explains at which stages the individual components of the groups are so abandoned;²⁰⁸ at this point, however, only four groups particularly relevant to this first chapter of Abhidhammatthasaṅgaha are discussed. The four concerned are:

- 1) THE ARISING OF UNSKILFUL CONSCIOUSNESS (*akusala-cittuppādā*).
- 2) THE PATHS OF UNSKILFUL ACTION (*akusala-kamma-pathā*).
- 3) THE LATENT TENDENCIES (*anusayā*).
- 4) THE FETTERS (*saṃyojanāni*).

511. It has already been shown how IGNORANCE (*avijjā*) and CRAVING (*tanhā*) become jointly apparent in the three bad roots, GREED, HATRED and DULLNESS AND DELUSION (*lobha, dosa, moha*). It has also been seen how those roots become manifest in the activity of the eight greedy, the two hateful and the two intensely dull and deluded integral states. It is these twelve bad states which constitute the group to be abandoned, entitled "the arisings of unskilful consciousness."

512. In what form do the twelve manifest themselves as action? They do so in whatsoever activity there is connected with the killing of beings, the taking of that which is not given, sexual misconduct, false speech, slanderous speech, harsh speech, frivolous talk, covetousness, illwill, and false view. As such, therefore, they are also direct manifestations of greed, hatred and dullness and delusion, and thereby of ignorance and craving. These ten categories of bad action constitute the group to be abandoned entitled "the paths of unskilful action."

513. In the process of destroying by the supramundane Paths the causes of rebirth and death, a most important feature to be recognized is the constant interaction taking place between ignorance and the activities occurring because of that ignorance. This reciprocity is particularly well demonstrated in the mutual dependence that exists between the two preceding groups and the so-called latent tendencies. These tendencies are so named because they represent hidden predispositions, inherent biases, or habitual inclinations towards engagement in the various

²⁰⁷ A direct reference to the seven Purities is given in the Rathavinīta sutta; M. Opammavagga, Sutta No. 4, Tr. M.L.S. vol. 1, p. 187 ff.

²⁰⁸ See Ppn. p. 798 ff. & P. Purity p. 838 ff.

categories of unskilful thought, speech, and bodily action, all of which are directly traceable to ignorance and craving. These tendencies exist from having been built up to a position of strength by the constant repetition of those same categories of mental and physical action, actions which the tendencies themselves have fostered; thus, as undesirable qualities, they accumulate strength from the very activities they promote. From this it is apparent that in order to bring this reciprocal stimulation to an end, not only must the undesirable mental and physical actions be abandoned, but the latent tendencies also.

514. The latent tendencies are:

- 1) THE LATENT TENDENCY OF LUST FOR SENSE PLEASURE (*kamaraganusaya = kāma + raga + anusaya*).
- 2) THE LATENT TENDENCY OF REPULSION (*pajighanusaya*).
- 3) THE LATENT TENDENCY OF CONCEIT (*mānānusaya*).
- 4) THE LATENT TENDENCY OF WRONG VIEW (*diṭṭhānusaya*).
- 5) THE LATENT TENDENCY OF DOUBT (*vicikicchānusaya*).
- 6) THE LATENT TENDENCY OF LUST FOR BECOMING (*bhavarāgānusaya*).
- 7) THE LATENT TENDENCY OF IGNORANCE (*avijjānusaya*).

It is these seven categories of inherent bias which constitute the group to be abandoned, entitled “the latent tendencies.”

515. The fourth group for abandonment by the supramundane Paths consists of the ten fetters. Consequent upon “action cumulative of resultant tending towards rebirth,²⁰⁹” these fetters are so consistently nourished and strengthened as to bind and shackle the aggregates of BECOMING (*bhava*) to *samsāra*, the repeated cyclic sequence of rebirth and death.

516. The ten fetters are:

- 1) Sakkāya-diṭṭhi-saṃyojana = The fetter of individuality view.

This comprises the many hypotheses put forward by those who maintain the existence of an enduring personal SELF or SOUL (*atta*) as being corporate with the five aggregates either individually or collectively, or, alternatively, as something quite apart from these.²¹⁰

517. 2) Vicikicchā-saṃyojana = The fetter of doubt.

By this is meant doubt in the Teacher (i.e., the Buddha), both as to his person and accomplishments; doubt in the efficacy of his Teaching (i.e., the Dhamma) as leading to ultimate release; doubt as to whether, dwelling in the Order (i.e., the Sangha), there are those who have thus achieved release; doubt as to the three aspects (i.e., the highest development of *sīla*, *bhāvanā* and *paññā*) of one’s own training towards release.²¹¹

518. 3) Silabbata-parāmāsa-saṃyojana = The fetter of adherence to habits and practices. (Often translated as “holding to mere rite and ritual”).

This involves the BEING ATTACHED TO (*parāmāsa*) HABITUAL BEHAVIOUR (*sīla*) and PRACTICE (*vata*) not in accordance with Right View. It is the belief that behavioural forms alone suffice to ensure forward progress. Originally it applied more particularly to the practices of ascetics who copied the life-styles of certain animals (“*Diṭṭhi*” applies here also).

²⁰⁹ See par. 126 ff.

²¹⁰ See also “*diṭṭhi*”, par. 82 ff.

²¹¹ See also “*vicikicchā*,” par. 160 ff.

519. 4) Kāma-rāga-saṃyojana = The fetter of lust for sense pleasure.

This is the name applied to the obsessive, addictive, and compulsive aspect of desire for sense pleasure experienced by way of the five physical senses and the mind. It is a most tenacious manifestation of the ROOT OF GREED (*lobha-mūla*).²¹²

520. 5) Paṭigha-saṃyojana = The fetter of repulsion.

This represents the attitude of antipathy and aversion taken towards whomsoever or whatsoever has done one harm, worked to one's disadvantage or caused unreasonable vexation. It is a deeply seated manifestation of the ROOT OF HATRED (*dosa-mūla*).²¹³

521. These are the FIVE FETTERS BELONGING TO LOW (*pañc oram-bhāgiyāni sam yojanāni*) existence.

522. 6) Rūpa-ragā-saṃyojana = The fetter of lust for Rūpāvacara existence.

523. 7) Arūpa-rāga-saṃyojana = The fetter of lust for Arūpāvacara existence.

Where the fetter of lust for sense pleasure has been exhausted and abandoned, and, in consequence of that, all lust for Kāmāvacara existence as well, these two higher fetters represent what still remains to be abandoned of LUST FOR REBIRTH (*bhava-raga*) into conditioned existence. ("Craving" and "greed" apply here also).

524. 8) Māna-saṃyojana = The fetter of conceit.

Resulting from the small but systematically diminishing degrees of attachment²¹⁴ accompanying the first three supramundane Paths, in this context conceit represents the residuum of the concept "I am."²¹⁵

525. 9) Uddhacca-saṃyojana = The fetter of distraction.

As a mental concomitant "distraction" is invariably present together with "dullness and delusion" in all unskilful integral states. In the context of supramundane realization, therefore, it represents the tiny residuum of mental disquiet and unsteadiness that can occur prior to the complete dissipation of all remaining DEFILEMENTS (*āsava*) supported by and supportive of ignorance.²¹⁶

526. 10) Avijjā-saṃyojana = The fetter of ignorance.

In the supramundane context, and prior to its utter destruction and eradication by RIGHT VIEW (*samma-diṭṭhi*), ignorance—having the General Characteristic of "absence of knowing"—represents the residuum of defiling qualities which, as its Concurrent Footing, retard full and final-penetrative realization of the FOUR NOBLE TRUTHS (*cattāri ariya-saccāni*).²¹⁷

²¹² See also "lobha," par. 69 ff.

²¹³ See also "dosa," par. 143 ff.

²¹⁴ Here ATTACHMENT (*upādāna*) refers specifically to one only of the four attachments, viz., *kamupādāna*, and not to *sakkāyadiṭṭhisamyojana*, the fetter of individuality view. Because this attachment is causally linked to desire for Rūpāvacara and Arūpāvacara existence, there occurs the subtle conceit "I am experiencing this or that condition."

²¹⁵ See also "conceit," par. 88.

²¹⁶ See also "uddhacca," par. 163 ff.

²¹⁷ See also "avijjā," par. 156 ff.

527. These are the FIVE FETTERS BELONGING TO HIGH (*uddham-bhāgiyāni sam-yojanani*) existence.

528. It is these ten categories which constitute the group to be abandoned entitled “the fetters.” This concludes the section dealing with certain of the major factors inimical to complete supramundane realization.

ABHIDHAMMATTHASAṄGAHA Talk No. 10 (Part I)

529. Prior to that point beyond which Nibbāna becomes the object of consciousness, it is evident from what has been said previously that it is necessary for the essential Knowledges and Purities to be realized inasmuch as they constitute a vital aspect of “the way leading to the cessation of suffering.” This represents the positive aspect of gaining penetrative insights. In spite of this, though, the negative aspect, which throughout has been inimical to progress, is not completely swept away at the instant that initial penetrative insight is achieved.

530. As has already become apparent, conditions such as the “arising of unskilful consciousness,” “paths of unskilful action,” the “latent tendencies,” the “fetters” and many other groups, far from representing a single impediment to progress, constitute a whole series of widely differing obstructions originating from past action and tendency. For this reason it was mentioned earlier²¹⁸ that because of these many retarding qualities it is necessary to investigate the several stages through which supramundane realization proceeds before reaching finality, observing at the same time the relationship between these stages and the progressive weakening and elimination of all such qualities.

531. Supramundane realization is divisible into four fundamental categories; categories which, considered in serial order, are seen to contribute both individually and collectively to this progressive weakening and abandoning of all qualities obstructive to penetrative insight. Each of these four categories, however, is sub-divided into two aspects, comprising first an integral conscious state productive of immediate resultant, and second the resultant itself corresponding to that particular productive state. Of these sub-divisions the initial phase in respect of each of the four main categories is called PATH CONSCIOUSNESS (*magga-citta*), or just PATH (*magga*), making in all a total of four classes. The second phase, consisting of the individual and direct Resultants of these four classes, is known as FRUITION CONSCIOUSNESS (*phala-citta*), or just FRUITION (*phala*), and it likewise makes in all a total of four classes.

532. In terms of Path and Fruition, therefore, the complete process of supramundane realization is developed in eight distinct phases, each phase representing a unique and highly specialized class of supramundane integral conscious state, each taking Nibbāna as its object. These supramundane states are classified in verses 31-34 inclusive of Abhidhammatthasaṅgaha as follows:

VERSE 31

SOTĀPATTI-MAGGA-CITTAM
SAKADAGAMI-MAGGA-CITTAM
ANĀGĀMI-MAGGA-CITTAM
ARAHATTA-MAGGA-CITTAN CE TI
IMĀNI CATTARI-PI LOKUTTARA-KUSALA-CITTĀNI NAMA.

Meaning:

IT IS THUS (*iti*) PATH CONSCIOUSNESS (*magga-citta*) of STREAM-ENTRY (*sotāpatti*),²¹⁹ Path consciousness of ONCE-RETURN (*sakadāgāmi*)²²⁰ Path consciousness of NON-RETURN (*anagāmi*), AND (*ca*) Path consciousness of ARAHANTSHIP (*arahatta*). THESE (*imāni*) FOUR

²¹⁸ See par. 509.

²¹⁹ See par. 556.

²²⁰ fr. sakim and āgacchati; see also Saddanīti, Sandhikappa par. 1827.

TOGETHER (*cattāri pi*) ARE KNOWN AS (*nāma*) GOOD (*kusala*) productive SUPRAMUNDANE (*lokuttara*) integral CONSCIOUS STATES (*cittāni*).

VERSE 32

533. SOTAPATTI-PHALA-CITTAM
SAKADĀGĀMI-PHALA-CITTAM
ANAGAMI-PHALA-CITTAM
ARAHATTA-PHALA-CITTAN CE TI
IMĀNI CATTĀRI PI LOKUTTARA-VIPĀKA-CITTĀNI NAMA

Meaning:

IT IS THUS (*iti*):

FRUITION CONSCIOUSNESS (*phala-citta*) of stream-entry, Fruition consciousness of once-return, Fruition consciousness of non-return, and Fruition consciousness of arahantship. These four together are known as RESULTANT (*vipāka*) supramundane integral conscious states.

VERSE 33

534. ICCEVAM SABBATHĀ PI ATTHA LOKUTTARA-KUSALA-VIPĀKA-CITTĀNI
SAMATTĀNI.

Meaning:

THUS (*iccevam*) FROM EVERY ASPECT (*sabbathā pi*) the EIGHT (*attha*) SUPRAMUNDANE (*lokuttara*) GOOD (*kusala*) productive and RESULTANT (*vipāka*) integral CONSCIOUS STATES (*cittāni*) are FULLY COMPLETED (*samattani*).

VERSE 34

535. CATU-MAGGAPPABHEDENA
CATUDHĀ KUSALAM TATHA
PĀKAM TASSA PHALATTA TI
ATTHADH ĀNUTTARAM MATAM.

Meaning:

BECAUSE OF THE FOUR DEMARCATIONS OF THE PATH (*catu-magga-pabhedena*), GOOD (*kusala*) productive consciousness is FOURFOLD (*catudha*), SO LIKEWISE (*tathā*) is the RESULTANT (*paka*) OF THAT (*tassa*), the STATE OF FRUITION (*phalatta*), THUS (*iti*) THE UNSURPASSABLE (*anuttara*) is REGARDED AS (*mata*) EIGHTFOLD (*atthadhā*).

536. This is the basic classification of SUPRAMUNDANE (*lokuttara*) integral conscious states fundamental to attainment of penetrative insight, i.e., KNOWLEDGE IN ACCORDANCE WITH ULTIMATE REALITY (*yathābhūtanāna*). Thus, irrespective of the method of training and practice engaged in, these eight states constitute the actual realization of that insight from its initial phase of entering the stream to that of its absolute culmination in the Fruition of arahantship. In this connection, however, these states, in addition to being referred to as supramundane, are also known as UNSURPASSABLE (*anuttara*). The purpose of this is to make plain that not only do they represent as a group the absolute peak of attainment beyond which there is nothing higher, but they are each, in an individual sense, unique states in that they are determining factors in the elimination of particular qualities inimical to final emancipation from the rounds of rebirth and suffering. None, therefore, can be omitted or be substituted by any other state whatsoever.

537. Quite apart from this classification referring to these eight most important integral conscious states, it also relates to the specific categories of persons concerned in their arising. Thus, in the “Grouping of Human Types by Eight” in the fourth book of the Abhidhammapiṭaka, entitled Puggala Paññatti—A Designation of Human Types, it says:²²¹

“Herein, which are the persons possessed of the four Paths, possessed of the four Fruitions?

1. “The stream-entrant.
2. “One who, following the course, realizes Fruition of (that state of) stream-entry.
3. “The once-returner.
4. “One who, following the course, realizes Fruition of (that state of) once-return.
5. “The non-returner.
6. “One who, following the course, realizes Fruition of (that state of) non-return.
7. “The arahanta.
8. “One who, following the course, realizes the Fruition of arahantship.”

“Those possessed of the four Paths, those possessed of the four Fruitions, are the persons.”

538. From what has been said concerning supramundane states and the categories of persons identified with them, it is apparent that each of the four main stages of the Path leading to final emancipation is of two parts, attainment, and fruition. In chapter four of Abhidhammatthasaṅgaha, where the many different courses of conscious process are fully discussed, the phase of attainment is shown to consist of but a single thought moment of SUPRAMUNDANE GOOD (productive) CONSCIOUSNESS (*lokuttara-kusala-citta*); then, as the immediate outcome of that productive state, there follow two, or sometimes three, thought moments of SUPRAMUNDANE RESULTANT CONSCIOUSNESS (*lokuttara-vipāka-citta*). These resultants arise as serial instants contiguous with the moment of attainment, but being the outcome of extremely powerful states they are nevertheless instants of FULL-AWARENESS (*javana*) even though they are resultants.

539. At the time of each of the four stages of Path attainment, therefore, there arise totals of three or sometimes four consecutive thought moments taking Nibbāna as their object, but which at the same time perform their functions as part of the full-awareness phase of a single, but unique, course of CONSCIOUS PROCESS (*citta-vīthi*). In view of this analysis in terms of thought moments it can be appreciated that when in the Piṭakas it is stated that eight classes of persons experience the Paths and Fruitions, it is a statement made in the strictly analytical sense showing that he who experiences the instant of attainment is one who has not experienced Fruition; moreover, that he who experiences Fruition is not one experiencing the instant of attainment. In the conventional sense, however, whosoever attains the Path automatically experiences Fruition in one and the same course of conscious process.

540. While still considering these eight categories of persons it should be mentioned that they are frequently classified as two groups. The first comprises those who have attained the first three Paths and their Fruitions, together with him who has experienced only the moment of attainment of the fourth Path but not yet its Fruition. These seven persons, being technically still in the course of gaining perfection, are referred to as LEARNERS (*sekkha* or *sekha*). One who, besides these seven stages has also experienced Fruition of the fourth Path, having gained perfection, ceases then to be a learner. Such a one constitutes the second group, and is thus

²²¹ See also Human Types, p. 103, and for further examples Dial. vol. III, p. 238; G.S. vol. IV, p. 140; Verses of Uplift p. 67.

known as *asekkha*, the non-learner, often translated as “adept” but meaning one who has attained final emancipation, i.e., ARAHANTSHIP (*arahatta*).

541. To add yet a third group: whosoever has made no such supramundane attainment, he is a PERSON (*jana*) SEPARATED (*puthu*) from those who experience Nibbāna. For this reason he is known as *puthujjana*, i.e., a worldly person, the average man.

542. The first of the four Paths is known as *sotāpatti magga*, i.e., the Path of stream-entry. As general usage, however, since Path attainment and its Fruition are contiguous instants of consciousness, the term *sotāpatti magga* is customarily applied to the overall condition. Following on this, therefore, one who has attained to that Path and Fruition is called *sotāpanna*, i.e., the stream-entrant.

543. The course of Knowledges and Purities leading up to that attainment have already been touched upon. Other features connected with its background and meaning are explained very clearly in a conversation between the Buddha himself and Ayasmā Sāriputta; this is recorded in the second Sāriputta Sutta in the Mahāvagga of Saṃyutta Nikāya.²²² Here in shortened form is an extract of the essential elements of that sutta:

“... What, then, Sāriputta are the factors contributive to stream-entry?”

“Indeed, Sir, the factors contributive to stream-entry are: association with worthy men; hearing the correct teaching; proper attention, also knowledge and its associated practice in conformity with actuality.”

“That is so, Sāriputta. What, then, Sāriputta, is the meaning of ‘stream?’”

“Indeed, Sir, just this, the Noble Eight Constituent Path; that is: right view, right thought, right speech, right action, right livelihood, right effort, right mindfulness, and right concentration.”

“That is so, Sāriputta. What, then, Sāriputta, is the meaning of ‘stream-entrant?’”

“Indeed, Sir, whosoever is imbued with this Noble Eight Constituent Path, such a one is called stream-entrant.”

“Good, that is so, Sāriputta ...”

544. In connection with Path attainment it has already been shown how, with realization, there comes about a transition from that which is a profound but still mundane understanding of the Three Characteristics and four Noble Truths, to that which constitutes supramundane penetrative insight into their real nature. In addition, it is apparent from the sutta quoted that the *sotāpanna* is one imbued with, that is, completely involved with and dominated by, the qualities inherent in the Noble Eight Constituent Path. This being so, not only in the case of the *sotāpanna* but of the other three Paths also, it is in consequence possible to observe the relationship between the several groups of undesirable qualities discussed earlier, and the presence and activity of that Noble Eight Constituent Path as the cause of their abandonment.

545. In the Mahācattārisakasutta,²²³ the Buddha discourses in considerable detail on the manner in which “right view,” “right effort” and “right mindfulness” co-operate in the putting away of evil qualities inimical both to themselves and to the remaining Path constituents. It is a sutta which, besides illustrating very clearly this relationship of abandonment, also demonstrates the causal interdependence existing between the Path constituents themselves.

²²² See also G.S. Vol. V, p. 302.

²²³ Majjhima nikāya, Uparipannasa, Anupadavagga; see also M.L.S. vol. 3, p. 113 ff.

The following, although not a direct translation, nevertheless paraphrases the substance of much that is relevant to the present question.

546. RIGHT VIEW (*sammadiṭṭhi*), in its ultimate sense being that which comprehends in accordance with actuality, abandons “wrong view,” such as acceding to incorrect doctrines, evil friendship, absence of desire to see Noble Ones (i.e., *ariyas*), improper attention, and so on.

547. RIGHT THOUGHT (*samma-saṅkhappa*), proceeding from “right view,” abandons “wrong thought,” such as that connected with sense pleasure, illwill, cruelty, etc.

548. RIGHT SPEECH (*samma-vaca*), proceeding from “right view” and “right thought,” abandons “wrong speech,” such as false speech, slanderous speech, harsh speech, frivolous speech, etc..

549. RIGHT ACTION (*samma-kammanta*), proceeding from “right view” and “right speech,” abandons “wrong action,” such as killing beings, taking that which is not given, wrong behaviour in respect of sense pleasures (e.g., sexual misconduct), etc..

550. RIGHT LIVELIHOOD (*samma-ājīva*), proceeding from “right view” and “right action,” abandons “wrong livelihood,” such as that connected with guile, insinuating talk, signification, defamation, seeking further gain based on present gain, etc..

551. RIGHT EFFORT (*sammāvāyāma*) proceeds from “right view” and “right livelihood.”

552. RIGHT MINDFULNESS (*samma sati*) proceeds from “right view” and “right effort.”

553. RIGHT CONCENTRATION (*samma samādhi*) proceeds from “right view” and “right mindfulness.”

554. It was said earlier²²⁴ that the purely practical, problem of making progress towards freedom from causal bondage, and to ultimate realization of Nibbāna, depends fundamentally upon proper cultivation of the threefold interdependence of moral practice, mental development and wisdom. These three demarcations are clearly to be seen in the Noble Eight Constituent Path, for MORAL PRACTICE (*sīla*) means “right speech,” “right action” and “right livelihood,” MENTAL DEVELOPMENT (*bhāvanā*) means “right effort,” “right mindfulness” and “right concentration,” and WISDOM (*paññā*) means “right view” and “right thought.”

555. Because of their causal association and interdependence, as demonstrated by the sutta, each of these three groups pervades the entire process of Path attainment. Nevertheless, localized dominance is clearly apparent, for as the Pathamasikkhasutta points out,²²⁵ moral practice is of immediate importance where attainment of the Paths of stream-entry and of once-return are concerned; mental development—more specifically concentration—in the case of the Path of non-return, and wisdom for the Path of arahantship.

556. To consider now the actual abandonment, or in certain cases the weakening, of undesirable qualities. Here, the sotāpatti magga moment is the initial instant of entry into the stream constituting supramundane realization of the Noble Eight Constituent Path; moreover, it is important to recognize that this stage is the only point of entry to that stream. Therefore, although the word sotāpatti magga is customarily translated as THE PATH (*magga*) of STREAM (*sota*) ENTRY (*āpatti*, from the verb *apajjāti* = enters, gets into), Abhidhammatthavibhaviṇi, the commentary on Abhidhammatthasaṅgaha makes a particular feature of enlarging upon this

²²⁴ See par. 277.

²²⁵ Aṅguttara Nikāya, Tatiyanipāta, Samanavagga dutiya-pannasa; see also G.S. vol. 1, p. 211; also summary Ppn. p. 6, par. 14.

meaning by emphasizing the essentially initiatory nature of this entry by showing its meaning to be THE PATH (*magga*) of INITIATORY ENTRY INTO (*a + patti*, from *ādito* and *pajjanam*, meaning “from the beginning” and “gone into”) THE STREAM (*sota*).

557.²²⁶ The preparatory work performed in the process of gaining the Knowledges and Purities, coupled with mundane practice of the three aspects of the Noble Eight Constituent Path, has been shown as that which leads up to the point at which this initiatory entry to the Path takes place. The immediate effect of the actual transition from mundane to supramundane is that he who thereby becomes sotāpanna automatically abandons those undesirable qualities inimical to that state. Thus, in respect of the “ten fetters” there is abandonment of:

THE FETTER OF INDIVIDUALITY VIEW (*sakkāyadiṭṭhisamyojana*).

THE FETTER OF DOUBT (*vicikicchāsamyojana*).

THE FETTER OF ADHERENCE TO HABITS AND PRACTICES (*sīlabbataparāmāsasamyojana*).

558. In addition to this there is a weakening of the “fetter of lust for sense pleasure” and the “fetter of repulsion,” in that the grossest forms of greed, also the meanness and envy associated with hatred, all of which are directly causative of rebirth into woeful existence, come to cessation.

559. Concurrent with this, certain of the “latent tendencies” also disappear; thus there is complete abandonment of:

THE LATENT TENDENCY OF WRONG VIEW (*diṭṭhanusaya*).

THE LATENT TENDENCY OF DOUBT (*vicikicchānusaya*).

560. At the same time there comes an end to certain “paths of unskillful action,” thus there is no further:

KILLING OF BEINGS (*panatipata*).

TAKING THAT WHICH IS NOT GIVEN (*adinnadana*).

SEXUAL MISCONDUCT (*kamesumicchācara*).

FALSE SPEECH (*musavada*).

WRONG VIEW (*micchādiṭṭhi*).

561. Coupled with these, the possible “arisings of unskillful consciousness” are curtailed by the complete abandonment of five unskillful integral conscious states, thus:

The two greedy states accompanied by mental pleasure; as well as the two accompanied by neutral feeling; all associated with “wrong view” and either uninstituted or instigated. The single state rooted in “dullness and delusion,” accompanied by neutral feeling and associated with “doubt.”

562. Such are the individual conditions abandoned, or weakened, by the sotāpanna, from among the four groups selected from the eighteen categories discussed in Visuddhimagga.²²⁷

563. Following the Path and Fruition of the sotāpanna the next stage of attainment realized by cultivation is sakadāgāmiṃmagga, the Path of once-return. Whosoever, by effort in weakening to a specific degree the inimical qualities remaining from the Path of stream-entry, experiences the instants of Path consciousness and Fruition that arise only on account of that weakening; such a one is known as sakadāgāmi, the once-returner. Realization of this, the second phase of the Path, indicates that there has been achieved this general weakening throughout the remaining seven “fetters,” five “latent tendencies,” seven “paths of unskillful action” and seven “arisings of

²²⁶ See chart 15. (pars. 557-566 inc.)

²²⁷ See Ppn. p. 798 ff. and P. Purity, p. 838 ff.

unskilful consciousness." This weakening is, however, more pronounced in the "fetters," and so on, which represent sense pleasure in the more apparent forms of greed, or where hatred is concerned. Thus, regarding the "arisings of unskilful consciousness," six states, i.e., the four integral states dissociated from "wrong view," also the two states rooted in hatred, although not completely eliminated, are nevertheless much attenuated.

564. The Path and Fruition of the sakadāgāmi is followed by development and practice leading to the third phase of the Path, the realization of anāgāmi, the Path of non-return. He who makes this attainment is known as anāgāmi. This Path, as with the preceding, arises as the outcome of yet further attenuation of bad qualities. In this instance, however, certain of these disappear completely; thus there is elimination of:

THE FETTER OF LUST FOR SENSE PLEASURE (*kamaragasamyojana*).

THE FETTER OF REPULSION (*patighasamyojana*).

Also

THE LATENT TENDENCY OF LUST FOR SENSE PLEASURE (*kamaraganusaya*).

THE LATENT TENDENCY OF REPULSION (*patighaanusaya*).

Of the "paths of unskilful action" there is abandonment of:

SLANDEROUS SPEECH (*pisunavaca*).

HARSH SPEECH (*pharusavaca*).

ILLWILL (*byapada*).

Of the "arisings of unskilful consciousness" there is curtailment of the more subtle aspects of the four greedy integral states dissociated from "wrong view," but there is complete abandonment of the two unskilful states rooted in hatred.

565. With the realization of the Path and Fruition of the anāgāmi, there remains only the fourth phase to be realized. This comprises the Path and Fruition known as arahattamagga, the Path of arahantship. He who experiences this Path and its Fruition is one fully emancipated from the entire process of repeated rebirth and death, and, in consequence, from the suffering entailed by those conditions. Such a one is known as arahanta, and it is he alone who can say, "Destroyed is birth, fulfilled is the Supreme Practice, done is what is to be done, there is no further conditioned state."²²⁸

566. Simultaneously with this attainment, and as the result of supreme effort and understanding, there comes about the final abandonment of all remaining inimical qualities, thus:

The five "fetters" of high existence, i.e.,

THE FETTER OF LUST FOR RŪPĀVACARA EXISTENCE (*rūparagasamyojana*).

THE FETTER OF LUST FOR ARUPĀVACARA EXISTENCE (*arūparagasamyojana*).

THE FETTER OF CONCEIT (*manasamyojana*).

THE FETTER OF DISTRACTION (*uddhaccasamyojana*).

THE FETTER OF IGNORANCE (*avijjā samyojana*).

The remaining three "latent tendencies:"

THE LATENT TENDENCY OF LUST FOR BECOMING (*bhavaraganusaya*).

THE LATENT TENDENCY OF CONCEIT (*mananusaya*).

THE LATENT TENDENCY OF IGNORANCE (*avijjā nusaya*).

²²⁸ Lit. "the state of being here," i.e., the state of conditioned existence. See also Dialogues of the Buddha, vol. 1, p. 83.

The remaining "paths of unskilful action":

FRIVOLOUS SPEECH (*samphappalapa*).

COVETOUSNESS (*abhijjhā*).

Also the remaining "arisings of unskilful consciousness": i.e., the four unskilful states rooted in greed, dissociated from "wrong view," uninstigated and instigated. The single integral state rooted in "delusion," accompanied by neutral feeling, associated with "distraction."

567. As previously explained, this analysis, showing the progressive elimination of bad qualities with the arising of the successive stages of the supramundane Path, is based on only four such inimical groups; nevertheless, from the examples the general pattern and sequence of abandonment is shown as being controlled by the localized dominance of individual elements of the Noble Eight Constituent Path. Earlier it was said that those who have gained supramundane insight are fully pervaded by the characteristics of that Path, and have become one with it. However, as the suttas quoted have indicated, only where there is supramundane establishment of "right view" are the other constituents of that Path able to do more than inhibit bad qualities. Thus it is that when as the culmination of the mundane Knowledges and Purities there comes about true establishment of "right view," then is the time of realization of the Path of stream-entry.

568. With that realization the "fetters" of "individuality view," "doubt" and "adherence to habits and practices" are abandoned, thereby enabling the other elements of the Noble Eight Constituent Path to eliminate in proper sequence the residuum of evil tendency and practice built up throughout the past.

ABHIDHAMMATTHASAṄGAHA Talk No. 10 (Part 2)

569. In discussing the four Path states and their resultant Fruitions emphasis has largely been focussed on the moral practice, the mental development and the aspects of wisdom essential to their coming to be, and, arising from these, the systematic elimination of inimical states commensurate with each successive phase. It has also been seen how, with the individual development of each Path, the period of culmination consists of a short series of consecutive thought moments taking Nibbāna as their sole object.

570. Considered as a group the Paths and Fruitions represent the summit of achievement; the summit because Nibbāna is their object, thereby placing them in a category quite apart from all other aspects of mental development. However, apart from the momentary experiencing of Nibbāna on the four occasions of Path attainment, and, by training, of gaining the ability to cause subsequent and even prolonged arising of Fruitional states to occur, what is the essential difference of function between supramundane states and, for example, the higher categories of mundane states?

571. The straightforward answer to this is that all mundane activity productive of resultant is confined to “states cumulative of continuing rebirth and death,” whereas supramundane activity is represented wholly by “states dispersive of continuing rebirth and death.”²²⁹ This, however, is not so much an explanation as a statement, for the difference between these two groups has to do with the activity of ignorance and craving.

572. In the *Anguttara Nikāya*²³⁰ the Buddha, speaking of ignorance, says:
“... Not to be perceived is the ultimate point of ignorance beyond which, in the past, ignorance did not exist, but after which it came to be ...”

Following which, in the adjacent sutta, the Buddha makes use of the same words, but this time in respect of CRAVING FOR EXISTENCE (*bhava-tanhā*). In the *Saṃyutta Nikāya*²³¹ the Buddha, speaking of rebirth, says:

“... Unfathomable²³² is the beginning of this repeated cyclic sequence of rebirth and death. Not to be perceived is the starting point of beings obstructed by ignorance, fettered by craving, running on and going from life to life ...”

573. It is upon reading Suttas such as these that one is yet again brought abruptly face to face with the Buddha’s insistence on the strictly causal nature of existence as a whole, and thereby of beings in particular. This is even more strongly demonstrated by the opening words of the great causal sequence of *paṭiccasamuppāda*: “BECAUSE OF IGNORANCE THERE IS ACTIVITY (*avijjā-paccaya saṅkhāra*).” By way of clarification this can be expanded in the following manner: because of an absence of knowledge, i.e., of penetrative insight into the four Noble Truths regarding the nature of suffering, its cause, its cessation and the way leading to its cessation,²³³ there comes about, as a matter of strict causality, “action productive of resultant tending towards rebirth;” this as the outcome of integral conscious states, unskilful and skilful, rooted in or associated with craving.²³⁴

²²⁹ See par. 489 ff.

²³⁰ *Dasakanipāta*, *Yamakavagga*; See also G.S. vol. V, pp. 78 & 80.

²³¹ *Anamataggasamyutta*; see also K.S. vol. II, p. 118 ff.

²³² More lit. “incogitable.”

²³³ See also par. 156 ff.

²³⁴ See also par. 126 & preceding.

574. In that causal series the phrase, “because of ignorance there is activity,” represents past existence, either in its entirety or just in respect of any single life. It is thus a general statement, but one which effectively connects together what has been said in the suttas quoted by associating the manner in which ignorance and craving, by being productive of activity causative of the rounds of rebirth, operate as a self-perpetuating series. In this way it illuminates further the Buddha’s words, “... Unfathomable is the beginning of this saṃsāra ...”

575. On the basis of such a causal, relationship this so-called “being,” this complex of MENTAL QUALITIES (*nāma*) and MATERIAL QUALITIES (*rūpa*), this bonding together of the FIVE AGGREGATES (*pañca khandhā*) can, by way of a simile, be looked upon as a vortex motivated by craving in the ambience of ignorance. A vortex which, in its relentless revolutions of thought upon thought, life upon life, draws all to its centre, causing them to slide down to ever greater depths of ignorance and craving. It is a vortex which can never come to an end while the driving forces of ignorance and craving are yet present.

576. In this connection, therefore, by considering as a whole these two pronouncements by the Buddha, “Because of ignorance there is activity,” and “... Not to be perceived is the starting point of beings obstructed by ignorance ...” it is clearly evident that not only is the past without conceivable beginning, but that where there is no attempt to bring ignorance and craving to an end, and thereby quell the vortex of saṃsāra, the repeated cyclic sequence of rebirth and death for those so-called beings is likewise without conceivable end.

577. Of the three classes of beings, therefore, the WORLDLY PERSON (*puthujjana*), the LEARNER (*sekka*) and he who has attained to ARAHANTSHIP (*arahatta*), the first two, being undeveloped and partly developed respectively in penetrative insight into the Three Characteristics and the four Noble Truths, still have courses lying in saṃsāra. Thus in the case of the worldly person, whether his resultant producing integral consciousness be Kāmāvacara, or of the higher categories of mundane states, i.e., Rūpāvacara or Arūpāvacara, all are classifiable as “states cumulative of continuing rebirth and death.”

578. The second of the three classes of beings, the LEARNERS (*sekka*), includes the STREAM ENTRANT (*sotāpanna*), the ONCE-RETURNER (*sakadāgāmi*) and the NON-RETURNER (*anāgāmi*); to which is added, for technical reasons already indicated, the Path phase alone of the stages of final realization; totalling, in all, seven classes of persons when analyzed in terms of Path and Fruition attainment.²³⁵ As analysis has shown, the “learners” represent three specific degrees of progressive advancement towards final attainment reached in accordance with a clearly definable process of abandonment, or weakening, of inimical states. Considered as beings, however, whereof the absolute elimination of such qualities has not yet been effected, rebirth tendency still persists. This is so because, apart from states actually eliminated, the remaining integral states productive of resultant, although weakened to various degrees, are nevertheless still active in maintaining rebirth tendency. On the other hand, because of there having occurred penetrative insight into the Three Characteristics, the four Noble Truths and the Noble Eight Constituent Path, with the consequent arising of supra-mundane conscious states taking Nibbāna as their object, a crucial stage has been reached. It is a stage from which there is no possibility whatsoever of falling away, and because of which final attainment of arahantship is assured.

579. Here it should again be emphasized that supramundane states are experienced only on the occasions of individual Path attainment and its Fruition, and on such subsequent occasions where, by training, further Fruitional states are obtained. On all other occasions of action there

²³⁵ See par. 531.

occur appropriate resultant producing Kāmāvacara states, and if such is the individual practice, resultant producing Rūpāvacara and Arūpāvacara states.

580. Regarding the rebirth tendencies of the three classes of “learners,” it is said in connection with the sotāpanna,²³⁶ that because of the elimination of three “fetters,” rebirth cannot take place in any of the woeful planes of existence, i.e., Kāma-duggati-bhūmi. Apart from this, sotāpanna rebirth is divided into three types:

581. First. The “sattakkhattuparamo;” he who, from being possessed of relatively sluggish insight, takes rebirth seven times at the very most among devas and men before attaining the final release of arahantship.

582. Second. The “kolamkolo;” he who, being of sharper intelligence and greater penetrative ability, makes rebirth twice or three times, passing from one good family to another among devas and men before achieving arahantship.

583. Third. The “ekabiji,” he who, being of keen intelligence and penetrative insight, makes but one further birth in the human plane, and there attains the remaining Paths and Fruitions, so gaining arahantship.

584. Where, in connection with the first and second classifications of sotāpanna, mention is made of subsequent rebirth among devas and men, this refers specifically to rebirth in the seven happy planes of existence included in the total of eleven constituting the entirety of Kāmāvacara planes. Because of their pleasant aspects, these seven are named THE HAPPY PLANES OF SENSE DESIRE (*kāma-sugati-bhūmi*). This distinguishes them from the four woeful states known as THE UNHAPPY PLANES OF SENSE DESIRE (*kāma-duggati-bhūmi*)

585. With the impossibility of rebirth for the sotāpanna in these woeful states, it demonstrates the absolute limits of possibility of Kāmāvacara existence once the first stage of supramundane development has been completed. Apart from this Kāmāvacara limitation, however, additional rebirth can still be caused to occur in the higher deva planes, the Brahmaloaka, by those who practice jhāna to a degree generative of rebirth tendency towards those planes.

586. From time to time the term culasotāpanna occurs, meaning a “lesser stream-entrant.” This does not refer to one who has achieved the state of sotāpanna; neither does it represent a supramundane conscious state, nor any degree of supramundane attainment. It refers only to one who, in striving to develop Path states, has in the initial process of gaining the Knowledges and Purities reached the stage of establishing PURITY THAT CROSSES OVER UNCERTAINTY.²³⁷ To that degree, therefore, he is bound for the attainment of sotāpatti magga.²³⁸

587. The second category of “learner” is represented by the attainment achieved by the sakadāgāmi. This is a supramundane stage reached without the elimination of any “fetter” or “latent tendency” beyond the three already abandoned by the preceding Path. It is, therefore, as has already been shown,²³⁹ the direct outcome of the extent to which “greed,” “hatred” and “dullness and delusion” have been yet further attenuated. As the result of this the rebirth tendency of the sakadāgāmi is so reduced as to make further rebirth in the human plane possible once, and once only. However, as to whether final emancipation is indeed to take place in the world of men, depends on the extent to which residual grasping for human existence itself

²³⁶ See Tikanipāta-anguttara, Dutiya-sikkhā-sutta; see also G.S. vol. 1, p. 213, and Ppn. p. 834.

²³⁷ *kaṅkha-vitaraṇa-visuddhi*, see par. 502.

²³⁸ See Ppn. p. 703.

²³⁹ See par. 563.

is present at the time of the sakadāgāmi's rebirth. It should be added that, as with the sotāpanna, the sakadāgāmi is quite immune from rebirth in the kāmāduggatibhūmi, the unhappy planes of sense desire.

588. The third category of "learner" is the anāgāmi; such a one is the non-returner. He, by eliminating the two remaining "fetters" of the group known as the "five fetters belonging to low existence,"²⁴⁰ has, with the consequent abandoning of the "fetter of lust for sense pleasure," completely destroyed all tendency to rebirth throughout the entirety of planes of existence characterized by sense desire and pleasure. In consequence of this, should one who has achieved the state of anāgāmi in the Kāmaloka fail during that same life to reach the stage of arahantship, by eliminating the remaining "five fetters belonging to high existence,"²⁴¹ he is still subject to rebirth. However, since as a non-returner there is no tendency whatsoever towards return to the Kāmaloka, the new arising takes place in an appropriate plane of the Brahmaloaka, known by the group title of Suddhāvāsabhūmi. Here, final attainment is made either rapidly or after prolonged existence, but always in accordance with one or other of five specific modes, depending upon the tenacity of those five remaining "fetters."

589. That completes the summary of rebirth conditions occurring in respect of those who experience the Path and Fruition stages of the stream-entrant, the once-returner, and the non-returner, i.e., six of the seven persons included in the class entitled "learners." The seventh is he who develops the single instant of Path consciousness of the arahanta. As that which follows immediately upon that Path instant constitutes the Fruition of final release, the classification "learner" clearly ends with the cessation of that particular Path instant. From this it is apparent that "learners" are still subject to rebirth tendency of varying degrees, even though controlled by the overall limitation imposed by inevitable arahantship.

590. The third and final class of persons comprises those who, because of the finality of their attainment, cannot any more be looked upon as "learners" they are, therefore, NON-LEARNERS (*asekkha*), or adepts. In terms of analytical definition they represent those who, having passed from the stage of "worldly person" onward through the seven supramundane stages of the "learner," emerge into the eighth supramundane stage, the final stage, the FRUITION OF ARAHANTSHIP (*arahatta phala*).

591. This class of person constitutes a single category only, the arahanta; literally, "the worthy one." In achieving this finality, all groupings of inimical states having their origins in ignorance and craving have been completely abandoned. Because of this, nothing remains by which any class of rebirth tendency can be produced. In consequence of this the arahanta is one entirely freed from "the repeated cyclic sequence of rebirth and death," *samsāra*.

592. As with "learners," however, the arahanta only experiences supramundane conscious states appropriate to his category at the time of the original moments of Fruition; or when, by training, he develops—and even prolongs—further experience of Nibbāna as the object of consciousness. In the course of his day to day activity, therefore, it is apparent that it is not supramundane conscious states which arise, but states commensurate with that day to day activity as a bhikkhu, a forest dweller, a teacher, and so on. In one not an arahanta it has been shown that comparable activities are associated with Kāmāvacara states, skilful and unskilful. These being either directly or indirectly associated with ignorance and craving, are thereby productive of rebirth tendency. In the case of the arahanta, all unskilful states having been completely eliminated, skilful states alone would appear to remain. The arising of such states is,

²⁴⁰ See pars. 516-521 inc.

²⁴¹ See pars. 522-527 inc.

however, equally out of the question owing to their indirect association with ignorance and craving, with consequent resultant producing properties; it is here, therefore, that the origins and purpose of the so-called INOPERATIVE (*kiriya*) states become apparent.

593. The arahanta in his daily life performs all customary activities, but from an utterly different standpoint from that of the ordinary man inasmuch as there is no association whatsoever, either directly or indirectly, with ignorance and craving. The action of the arahanta is, therefore, completely pure and free from all contaminants, and is in consequence quite incapable of being generative of any rebirth tendency whatsoever. For this reason his conscious states, instead of being productive of resultant, are non-productive of resultant.

594. Although his states, therefore, are for all practical purposes analytically indistinguishable from the good (productive) Kāmāvacara states of the “worldly person” and the “learner,” their non-productive quality effectively places them in an entirely separate category whereby they are known as INOPERATIVE (*kiriya*) states.²⁴² This applies not only to Kāmāvacara states, but to Rūpāvacara and Arūpāvacara states also; thus the several categories of *kiriya* states having roots, represent in every instance the activity of the arahanta which is entirely non-productive of rebirth tendency. This distinguishes it from the activity of all other mundane classes, these latter being invariably productive of rebirth tendency. When, therefore, the action of the arahanta is said to be inoperative, occasionally translated as ineffective, it in no way indicates that the action fails to produce its intended effect, it means only that it produces no rebirth tendency.

595. It was said earlier that this final class is of a single category only, the arahanta. Although correct, this needs some qualification, for although all who have attained the four Paths and four Fruitions are arahantas, there nevertheless exist certain clear differences between individual arahantas in respect of quite other, but necessarily associated, qualifications. Apart from these the nature of arahantship itself is without variation, it is established and absolute. Initially arahantas are separated into two categories. First are those who have no teacher from whom they could become acquainted with a knowledge of fundamental truths. For this reason the entire basis of their course leading to the Fruition of arahantship is self-evolved—such are the sammāsambuddhas and paccekasambuddhas. Second are those who do have a suitable teacher and thus gain a prior knowledge of fundamental truths. In this case the basis of their course leading to the Fruition of arahantship being already established, it cannot be said to be self-evolved. Such are the savaka arahantas and all remaining arahantas.

596. Sammasambuddhas, such for example as the Buddha Gotama, are fully self-enlightened-ones, arahantas possessed of absolute penetrative understanding and insight constituting that particular basis of knowledge known as “the ten powers of the Perfect One,” the Tathagatha.²⁴³ In these knowledges, and in all fundamental truths, they are, because of the extent of their research and practice, infinitely wise, all-knowing, and all-seeing. In addition to this they possess the supreme ability of being able to instruct and imbue others. This they do not only with a knowledge of those fundamental truths, but also with every necessary associated teaching, which, if practised with diligence and understanding, leads to final release from suffering.

598. Paccekasambuddhas, being arahantas in every degree, nevertheless differ very considerably from sammāsambuddhas, for although all their attainment up to and including the Fruition of arahantship has likewise been entirely self-evolved, i.e., quite without the aid of a teacher, the true nature of that realization does not become fully apparent to them. A

²⁴² The differences concerned are shown in Abhi/S. Chap. 2.

²⁴³ See Vbh., Ranavbh.; also B.o.A. par. 760 and 809-831 inc.

paccekasambuddha can be likened to a complete stranger visiting a great city for the first time, who, enjoying there the flavours of the very finest foods, while recognizing their supreme loveliness has no conception of what makes them so. In a comparable way the paccekasambuddha, while savouring the magnitude and bliss of his final attainment, is unable to distinguish therein the savour of truth in its ultimate sense. Because of this inability to distinguish, he is in consequence unable to awaken others to an understanding of actuality. As with all arahantas, apart from a sammāsambuddha, he is not possessed of “the ten powers of the Tathagatha.” Paccekasambuddhas are mentioned on several occasions throughout the Piṭakas; however, a considerable source of information concerning them is to be found in the preamble to the commentary on the Khaggavisanasutta of Suttanipāta.

599 Of those attaining arahantship, but who in so doing have nevertheless been instructed by a teacher capable of establishing the basis of their knowledge, the savaka-arahantas present a very particular example. The savaka-arahantas, i.e., the disciple arahantas, refer specifically to Ven. Sāriputta and Ven. Moggallāna, the two aggāsavakas, or pre-eminent disciples of the Buddha Gotama. Both of these attained to sotāpanna directly and indirectly from the teaching of Ven. Assaji, prior to their approaching the Buddha himself. The past history leading to their pre-eminence is one of long tradition, but at the time of the Buddha, Ven. Sāriputta was pre-eminent in wisdom and considered second only to the Buddha himself, while Ven. Moggallāna was pre-eminent in the practice of jhāna and the special abilities arising therefrom., He achieved arahantship only seven days after entering the Order, and Ven. Sāriputta some two weeks later. The textual order of the entire Abhidhammapiṭaka is traditionally ascribed to Ven. Sāriputta.

600. The “remaining arahantas,” both during the life-time of the Buddha and throughout the long period of the persistence of his teaching, refers to all who attain arahantship apart from the three preceding groups. The prerequisite for this in every case is that they should have a teacher capable of introducing them to the proper basis of knowledge for such attainment.

601. As has already been emphasized, release from the repetitive cycle of rebirth and death, that comes with the Fruition of arahantship, is an absolute condition, and therefore without variation in the nature of its finality of achievement. The details of the course of progress through the four Paths and their Fruitions can, however, show considerable variation according to individual emphasis. Thus, one person may have a more dominant initial concern with impermanence, another with suffering, and another with absence of soul. One may base his attainment on jhāna, another without such practice. For such and other reasons the modes of approach, continuation and final release can together be expressed in terms of seven categories. These, however, are only mentioned here in passing, as their discussion belongs properly to the final chapter of Abhidhammatthasaṅgaha.

602. Of the many ways in which factorial consciousness is associated with mental concomitants to produce integral conscious states, the eight supra-mundane states classified in Abhidhammatthasaṅgaha, verses 31-34 inclusive, completes the shorter of the two ways by which the totality of conscious states can be categorized. Thus in Abhidhammatthasaṅgaha, verse 35, a summary is made of the basic classes of integral conscious states in accordance with four groupings, viz., bad (productive), good (productive), resultant and inoperative.

VERSE 35

603. DVADAS AKUSALAN EVAM
KUSALAN EKAVĪSATI
CHATTIMS VA VIPĀKANI
KRIYA-CITTĀNI VĪSATI

Meaning:

IN THIS WAY (*evam*) there are TWELVE (*dvā dasa*) BAD states (*akusalani*), TWENTY-ONE (*eka vīsati*) GOOD states (*kusalani*), JUST (*eva*) THIRTY-SIX (*cha + timsa*) RESULTANTS (*vīpakāni*) and TWENTY (*vīsati*) INOPERATIVE (*kriya*) integral CONSCIOUS states (*cittāni*).

Analysis of Verse 35

604.

| | | |
|-------------------|----|---------------|
| Bad (productive). | | Akusala |
| Greedy | 8 | Lobha |
| Hateful | 2 | Dosa |
| Dull & deluded | 2 | Moha (momuha) |
| Total | 12 | |

| | | |
|------------------------------|----|-----------------|
| Good (productive) | | Kusala |
| Of the Plane of Sense Desire | 8 | Kāmāvacara |
| Of the Plane of Form | 5 | Rūpāvacara |
| Of the Formless Plane | 4 | Arūpāvacara |
| Supramundane Path | 4 | Lokuttara Magga |
| Total | 21 | |

| | | |
|------------------------------------------------|----|---------------------|
| Resultants | | Vipāka |
| Bad (rootless) | 7 | Ahetuka (akusala) |
| Good (rootless) | 8 | Ahetuka (kusala) |
| Good (with roots) of the Plane of Sense Desire | 8 | Sahetuka Kāmāvacara |
| Of the Plane of Form | 5 | Rūpāvacara |
| Of the Formless Plane | 4 | Arūpāvacara |
| Supramundane Fruition | 4 | Lokuttara Phala |
| Total | 36 | |

| | | |
|------------------------------------------------|---|---------------------|
| Inoperative | | Kiriya |
| Rootless | 3 | Ahetuka |
| Of the Plane of Sense Desire (with good roots) | 8 | Sahetuka Kāmāvacara |
| Of the Plane of Form | 5 | Rūpāvacara |
| Of the Formless Plane | 4 | Arūpāvacara |

| | | |
|-------|----|--|
| Total | 20 | |
|-------|----|--|

SUM OF THE FOUR TOTALS = 89 INTEGRAL CONSCIOUS STATES

605. These same states are shown in yet another way in Abhidhammatthasaṅgaha, verse 36, where they are classified accordingly as they are characteristic of one or other of the three mundane planes, or are supramundane.

VERSE 36

CATU-PANNĀSADHA KĀME
RŪPE PANNARAS ĪRAYE
CITTĀNI DVADAS ĀRŪPE
ATTHADE ĀNUTTARE TATHĀ

Meaning:

IN KĀMĀVACARA (*kāme*) terms consciousness is FIFTY-FOURFOLD (*catu-pannāsa + dha*); IN RŪPĀVACARA (*rūpe*) terms FIFTEEN (*paññārasa*) SHOULD BE DECLARED (*īraye*); IN ARŪPĀVACARA (*arupe*) terms there are TWELVE (*dvā dasa*) integral CONSCIOUS states (*cittāni*); IN COMPARABLE MANNER (*tathā*) IN “UNSURPASSABLE” (*anuttare*) terms consciousness is EIGHTFOLD (*attha + dha*).

Analysis of Verse 36

606.

| Of the Plane of Sense Desire | | Kāmāvacara |
|-------------------------------|----|------------------------|
| Greedy | 8 | Lobha |
| Hateful | 2 | Dosa |
| Dull & deluded | 2 | Moha |
| Bad rootless resultants | 7 | Ahetuka akusala vipāka |
| Good rootless resultants | 8 | Ahetuka kusala vipāka |
| Rootless inoperative | 3 | Ahetuka kiriya |
| Good (productive) | 8 | Kusala |
| Good resultant (with roots) | 8 | Sahetuka vipāka |
| Good inoperative (with roots) | 8 | Sahetuka kiriya |
| Total | 54 | |

| Of the Plane of Form | | Rūpāvacara |
|----------------------|----|------------|
| Good (productive) | 5 | Kusala |
| Resultant | 5 | Vipāka |
| Inoperative | 5 | Kiriya |
| Total | 15 | |

| | | |
|-----------------------|----|-------------|
| Of the Formless Plane | | Arūpāvacara |
| Good (productive) | 4 | Kusala |
| Resultant | 4 | Vipāka |
| Inoperative | 4 | Kiriya |
| Total | 12 | |

| | | |
|-------------------------|---|---------------|
| Supramundane | | Lokuttara |
| Good (productive), Path | 4 | Kusala, Magga |
| Resultant, Fruition | 4 | Vipāka, Phala |
| Total | 8 | |

SUM OF THE FOUR TOTALS = 89 INTEGRAL CONSCIOUS STATES.

607. Taking these two verses separately it will be seen that the totals of states listed are the same in each instance. From this it is clear that according to their most simple mode of classification there are eighty-nine types of integral conscious states. That completes the basic assessment of integral conscious states as a whole; it also concludes Part 2 of Talk No. 10.

ABHIDHAMMATTHASAṄGAHA Talk No. 11 (Part 1)

608. In verses 35 and 36 of Abhidhammatthasaṅgaha two separate methods of calculation are given, wherein each illustrates the complete range of eighty-nine integral conscious states. As both show this range as extending from the lowest degrees of ignorance and craving upward to the highest level of Path Fruition, it might well be concluded that there is now nothing more to say, and in consequence this first chapter could come to an end. Such, however, is not the case, for in verse 37, while clearly confirming this total of eighty-nine, there is brought to one's notice for the first time the alternative figure of one hundred and twenty-one.

VERSE 37

ITTHAM EK UNA-NAVUTI-PABHEDAM PANA MĀNASAM EKA-VĪSA-SATAM VĀ
THAVIBHAJANTI VICAKKHANA

Meaning:

IN THIS WAY (*ittham*) there are EIGHTY-NINE (*eka + ūna-navuti*) TYPES (*pabheda*) of MENTAL ACTIVITY (*mānasa*) or INDEED AS (*atha va pana*) THE DISCERNING (*vicakkhana*) ANALYZE (*vibhajanti*) ONE HUNDRED AND TWENTY-ONE (*eka + vīsam-sata*).

609. This poses a new question, for in view of the quite complete and all embracing basis of eighty-nine, how can this new figure of one hundred and twenty-one be explained without introducing new types of conscious states hitherto unmentioned? Verse 38 of Abhidhammatthasaṅgaha asks this very question, for in its opening words it says, "Katham ekunanavuti-vidham cittan ekavisasatam hoti?" Meaning: "How is it that eighty-ninefold consciousness becomes one hundred and twenty-one?"

610. Before discussing in detail how this takes place, it should be said in brief that the expansion is entirely concerned with the basis upon which the eight supramundane conscious states come into existence. But now, to re-examine certain major points directly concerned in the arising of such states.

611. It has already been mentioned on several occasions that supramundane penetrative insight may be arrived at by one or other of two ways. The first of these is called *sukkha-vipassanā*, i.e., simple, dry, or bare penetrative insight, where attainment is gained without the assistance afforded by the practice of *jhāna* in greatly enhancing the ability to concentrate. The second is known as *samatha vipassanā*, i.e., penetrative insight based on the practice of calm. Here, precisely the same degrees of attainment are gained as with *sukkha-vipassanā*, but in this instance by intentionally basing its occurrence on the practice of *jhāna*. By this latter method the much enhanced ability to concentrate, together with other advantages associated with *jhāna* such as a systematic inhibition of the "hindrances," renders the entire process of supramundane attainment more rapid and more subject to direction, stability, and control.

612. A third point, one which involves both these modes of realization, is that in the course of examining the entirety of conscious states it becomes apparent that they are logically separated into three major non-interpenetrating groups, i.e., *Kāmāvacara*, *Mahāggata*—embracing *Rūpāvacara* and *Arūpāvacara*—and *Lokuttara*, or supramundane states.

613. In connection with these three very characteristic groupings the immediate consideration is to observe the direct relationship that can take place between supramundane states and either of the other two groups. The first of these is the relationship between supramundane penetrative insight and *Kāmāvacara* states.

614. It was said earlier that a prerequisite for attainment is that a person's "constituent potentiality of being," i.e., the so-called stream of bhavaṅga, be three-rooted by way of the three good roots. This being so, it has been shown that a person practising good Kāmāvacara states accompanied by knowledge, can, by diligence and persistence, so develop mundane insight in respect of the Three Characteristics and four Noble Truths as to bring him to the very frontier point of supramundane penetrative insight. When such a condition has been reached, wherein mundane insight stands in exact conformity with supramundane penetrative insight, it is possible for there to take place a transition from the mundane levels of consciousness to the first supramundane Path and Fruition, with Nibbāna as the consequent object of consciousness.

615. Having succeeded thus far in realizing attainment, should that person then proceed to develop the remaining three Paths and three Fruitions in like manner, that is, without any application of the basis of jhāna, he reaches finality in attainment with the Fruition of arahantship as a sukkha vipassaka, i.e., a simple or "dry" attainer. Such a one is also known as paññā vimutto, i.e., one who has gained freedom on the basis of understanding only. He is also called suddhavipassaka or suddhavipassanāyanika, meaning that the mode of gaining insight is simple in that it is unmixed with any practice of jhāna.

616. In verses 31-34 of Abhidhammatthasaṅgaha the eight categories of Lokuttara states are given in fundamental terms, that is, just as Paths and Fruitions, with no additional information whatsoever as to the basis from which they have been developed. As has been indicated, but not yet discussed, the Paths and Fruitions can also be developed from a basis of jhāna; however, as will become apparent, when this is so it is clearly stated in classification. Consequently, where no such statement is made, the assumption is that realization is based on a skilful Kāmāvacara state.

617. Quite apart from this, though, it is emphasized most strongly that wheresoever supramundane states are mentioned, and no matter from which basis they are developed, it is fundamentally these eight that are referred to. There is no attainment classifiable as supramundane that does not realize, in due order, the four Path and Fruition stages, these alone take Nibbāna as their object. Verses 31-34 can therefore be said to represent not only the basic Path and Fruition states as a whole, but, in a more particular sense, the specific attainments of the sukkha vipassaka.

618. It is frequently emphasized that, throughout the practice leading from the condition of "worldly person," up to the Fruition of arahantship, it is essential that an appropriate balance be maintained between three vital aspects of the Buddha's Teaching, these being, MORAL PRACTICE (*sīla*), MENTAL DEVELOPMENT (*bhāvanā*), and WISDOM (*paññā*). The importance of this is illustrated by the manner in which these three form particular groups within the Noble Eight Constituent Path.²⁴⁴ If, however, as is often the case, mental development is thought of only as formal "meditational" practice, how can it be said that this balance is maintained in the instance of "dry" attainment?

619. Here, the implications of the word "bhāvanā" are important. Bhavana is associated with the Pali word bhāveti, and one of its meanings is "to develop an idea by dwelling on it." Because such action demands the exercise of specifically directed attention, by means of which mental one-pointedness is stimulated, bhāvanā is customarily rendered "mental development."

620. To dwell on an idea is also to concentrate on it, therefore mental development implies CONCENTRATION (*samādhi*). From this it is evident that to have dwelt upon and developed

²⁴⁴ See pars. 277 & 55 ff.

ideas from which have arisen the Knowledges and Purities leading to the threshold of supramundane insight, implies considerable concentration. Such concentration, in its turn, implies MENTAL DEVELOPMENT (*bhāvanā*). Thus it is that *bhāvanā* does not invariably refer to formal meditational practice; on the contrary, it frequently points to the mental development occasioned by systematic study and investigation directed to gaining penetrative insight. To this extent, therefore, one who makes “dry” attainment achieves, by way of study and research, that proper balance between *sīla*, *bhāvanā*, and *paññā*.

621. In this connection, however, it is plainly evident that the degree of concentration ordinarily associated with study alone, is, from the very nature of its task, of a variable and inconstant order. For this reason it is considerably less predictable than the one-pointedness of consciousness achieved by much more specifically directed practice. Consequently, much is to be gained from additional exercise so directed. Such practice is of inestimable value, and is directly reflected not only in the quality of essential study and investigation itself, but more importantly in gaining the mundane insight of the Knowledges and Purities leading to Path attainment.

622. Up to this point any increased ability to concentrate, thus gained by supplementary practice, has still been concerned with *sukkha-vipassanā*. This is because a level of concentration commensurate with the development of *Rūpāvacara* and *Arūpāvacara* *jhāna* has in no sense been involved. However, it is clearly evident that the benefits accruing from a very much improved ability to concentrate the mind are in no sense restricted only to the production of further skilful *Kāmāvacara* states.

623. That this is so is distinctly shown where formal training and practice in gaining concentration, and a proper balance of mental concomitants, has so far succeeded that the transition from *Kāmāvacara* states to *Rūpāvacara* states is actually brought about.²⁴⁵ As a practice directed to facilitating the arising of penetrative insight, such achievement presents an entirely different set of circumstances, for immediately on cultivation of *jhāna* the obstructive qualities of the “five hindrances” are completely inhibited. Because of this the ability to bring close attention to bear on IMPERMANENCE (*anicca*), SUFFERING (*dukkha*) and ABSENCE OF SOUL (*anattā*), as the objects of concentration prerequisite to the realization of that penetrative insight, is very considerably enhanced.

624. The coming to be of the supramundane states as based initially on skilful *Kāmāvacara* states has been discussed. However, where, because of the systematic inhibition of the “hindrances,” *jhāna* is made the “stepping off point” for attainment instead of *Kāmāvacara* states, it becomes necessary to calculate somewhat differently the modes of arising of those eight supramundane states.

625. In *Abhidhammatthasaṅgaha*, verse 21, it is shown how, because of the dominance of particular groupings of mental concomitants, there occur five distinct classes of integral conscious states, the *Rūpāvacara* *jhānas*. In addition to these, verse 26 names four *Arūpāvacara* *jhānas* which, because of their similarity of structure to the fifth *Rūpāvacara* *jhāna*, are considered as extensions of that state.²⁴⁶ Considered as a whole, therefore, these nine *jhānas* present five additional bases, or “stepping off points,” from which the transition from mundane consciousness to supramundane consciousness can be made.

²⁴⁵ See pars. 379 & 440.

²⁴⁶ See par. 478, also chart no. 13.

626. It has already been shown how from the basis of purely mundane objects, either material or non-material, the several integral conscious states known as *jhāna* are developed. It has also been shown how each *jhāna* is characterized by a particular combination of *jhāna* constituents, and is classified in accordance with them;²⁴⁷ if, therefore, a suitably trained person who possesses and has mastered the ability to attain *jhāna* wishes to cultivate and develop supramundane penetrative insight by making *jhāna* the “stepping off point” for this accomplishment, he adopts the following procedure.

627. First of all, on the basis of his customary mundane object of initial concentration, he develops, for example, the first *Rūpāvacara jhāna*. Having attained that state he is very serene, with the constituents of *jhāna* in a situation of dominance and thus with the “five hindrances” completely inhibited. At this stage the required basis for further development has thus been established; however, in order that supramundane penetrative insight may be realized, the true intrinsic nature of the Three Characteristics, *anicca, dukkha, anattā*, has first to be fully comprehended. That this may be done he then redirects his concentration, from the original object on which the *jhāna* was established to one or other of the Three Characteristics, being all the time most watchful that there is no loss of concentration or diminution in the other *jhāna* constituents.

628. If as the result of this redirection of concentration he does indeed gain penetrative insight into the single Characteristic selected, there comes about, quite automatically, supramundane insight into all three. With this there takes place the transition from the mundane conscious state, *jhāna*, to a new series of integral states which, although of similar structure to the *jhāna* just ceased, are nevertheless of a completely different category. These are the appropriate supramundane Path consciousness and its immediately following Fruition. Here the difference from the *jhāna* is very considerable, for despite their similarity of structure the object of the new states, instead of being mundane, is now the one and only supramundane object, *Nibbāna*, with its implication of complete abandonment—by way of the four Paths—of every defilement. In this way Path and Fruition states are said to be based on *jhāna*.

629. This example has been given as though based initially on the first *Rūpāvacara jhāna*; in practice, though, the *jhāna* selected depends both upon the ability and decision of the person concerned. In accordance with this, the *jhāna* constituents, etc., occurring in the resulting supramundane integral conscious state, correspond closely with those of the mundane *jhāna* originally developed.

630. For this reason, when classifying supramundane states, it is customary where a basis of *jhāna* obtains to name the individual *jhāna* concerned by coupling its category with the appropriate Path and Fruition. For example, if a person should attain to the Path of stream-entry on the basis of first *jhāna*, the type of consciousness is identified as, “first *jhāna* Path consciousness of stream-entry.” Meaning thereby that first *jhāna* has functioned as the “stepping off point” for the attainment of the Path state, and that the structure of that Path state itself is similar to, but not exactly, the same as that of the *jhāna* concerned. So likewise with the Path consciousness of once-return, of non-return and of the *arahanta*, showing thereby that the four Paths may be attained from the basis of first *jhāna*. It is similarly so with each of the remaining four *jhānas*. By this method, therefore, it can be said in respect of the five *jhānas*, that as each can act as the basis for the four individual Paths, there are in all twenty possible ways of approach leading to Path consciousness by way of the participation of *jhāna*.

²⁴⁷ See par. 440 ff.

631. As the Fruition of each Path has been shown as taking place in the same course of conscious process, a similar mode of classification is adopted for Fruition consciousness. Thus there are also twenty ways of approach leading to Fruition consciousness. From this it is apparent that for Path and Fruition together there are forty ways in which jhāna can participate.

632. In Abhidhammatthasaṅgaha, verses 38-40 inclusive, the question is both asked and elucidated as to how the eight unique supramundane states may be classified when entered upon from the basis of one or other of the jhānas. Initially it might well be considered that it would be quite sufficient just to indicate that such and such a Path state was realized from a basis of jhāna, and not to specify which particular jhāna. In the interests of reliable classification, however, this approach is quite unsuitable, for, as in terms of JHĀNA CONSTITUENTS (*jhānaṅgani*) each of the five jhānas differs fundamentally in its structure, thus constituting a completely different category of integral state, it is essential that in functioning as bases all such variant conditions be adequately shown. In order, therefore, that this may be made perfectly clear, verse 38, in speaking of the Path of stream-entry, states in detail the actual structure—in terms of jhāna constituents—of each integral state functioning as the basis from which this Path of supramundane realization can be entered upon, and thus of the relevant structure of the supramundane state itself.

633. Verses 39 and 40 show also that the same five bases of jhāna can apply to the remaining Path states and to the four Fruitions as well. Here again it is emphasized that realization of any one of the four Path states can, very naturally, only ever be made once. Consequently, although each jhāna constitutes a possible base for Path attainment, only one will be employed by an individual realizing any given supramundane Path.

VERSE 38

634.²⁴⁸ KATHAM EKUNANAVUTI-VIDHAM CITTAM EKAVISASATAM HOTI?
VITAKKA-VICARA-PITI-SUKH EKAGGATA-SAHITAM PATHAMAJJHĀNA-SOTAPATTI-
MAGGA-CITTAM.

VICARA-PITI-SUKH EKAGGATA-SAHITAM DUTIYAJJHĀNA-SOTAPATTI-MAGGA-
CITTAM.

PITI-SUKH EKAGGATA-SAHITAM TATIYAJJHĀNA-SOTAPATTI-MAGGA-CITTAM
SUKH-EKAGGATA-SAHITAM CATUTTHAJJHĀNA-SOTAPATTI-MAGGA-CITTAM
UPEKKH EKAGGATA-SAHITAM PANCAMAJJHĀNA-SOTAPATTI-MAGGA-CITTAN. CE
TI.

IMANI PANCA PI SOTAPATTI-MAGGA-CITTĀNI NAMA

Meaning:

HOW IS IT THAT (*katham*) EIGHTY-NINEFOLD (*ekūnanavuti-vidham*) CONSCIOUSNESS (*cittam*) BECOMES (*hoti*) ONE HUNDRED AND TWENTY-ONE (*eka + visam-sata*)?

INITIAL APPLICATION (*vitakka*) SUSTAINED APPLICATION (*vicāra*) ZEST (*pīti*) mental PLEASURE (*sukha*) and ONE-POINTEDNESS (*ekaggatā*), IN MUTUAL ASSOCIATION (*sahita*), constitute FIRST JHĀNA (*pathama + jhāna*) PATH CONSCIOUSNESS (*magga-citta*) of STREAM-ENTRY (*sotāpatti*);

Sustained application, zest, mental pleasure, and one-pointedness, in mutual association, constitute SECOND (*dutiya*) jhāna Path consciousness of stream-entry; Zest, mental pleasure and one-pointedness, in mutual association, constitute THIRD (*tatiya*) jhāna Path consciousness of stream-entry; Mental pleasure and one-pointedness, in mutual association, constitute FOURTH

²⁴⁸ See chart 15.

(*catuttha*) jhāna Path consciousness of stream-entry AND (*ca*) EQUANIMITY (*upekkhā*) and one-pointedness, in mutual association, constitute FIFTH (*pañcama*) jhāna Path consciousness of stream-entry. THESE (*imāni*) FIVE TOGETHER (*pañca-pi*) ARE KNOWN AS (*nāma*) integral CONSCIOUS STATES OF THE PATH (*magga-cittāni*) representing STREAM-ENTRY (*sotāpatti*).

VERSE 39

635. TATHA SAKADAGAMIMAGGA-ANAGAMIMAGGA-ARAHATTAMAGGA-CITTAN.
CE TI SAMA-VĪSATI MAGGA CITTĀNI.

Meaning:

IN LIKE MANNER (*tatha*) CONSCIOUSNESS (*citta*) of THE PATH OF ONCE-RETURN (*sakadāgāmi-magga*), of THE PATH OF NON-RETURN (*anagāmi-magga*) AND (*ca*) of THE PATH OF ARAHANTSHIP (*arahatta-magga*); THUS (*iti*) there are IN ALL (*sama*) TWENTY (*vīsati*) integral CONSCIOUS STATES of THE PATH (*magga-cittāni*).

VERSE 40

636. TATHA PHALA-CITTĀNI CE TI SAMA-CATTĀLĪSA LOKUTTARA-CITTĀNI
BHAVANTĪ TI.

Meaning:

SIMILARLY (*tatha*) THE FRUITION STATES OF CONSCIOUSNESS (*phala-cittāni*) AS WELL (*ca*); THUS (*iti*) IN ALL (*sama*) FORTY (*cattālīsa*) SUPRAMUNDANE (*Lokuttara*) integral CONSCIOUS STATES (*cittāni*) OCCUR (*bhavanti*).

637. By the grouping together of the jhāna constituents in a manner identical with that of the five basic categories of Mahāggata states, these verses illustrate one point very clearly; it is that where any one of those mundane jhānas functions as the "stepping off point" for the development of supra-mundane states, an individual Path and Fruition so realized maintains the same structure in terms of jhāna constituents as those of the integral state upon which it was based.

638. This being so, the question now arises as to the structural form taken by the Paths and Fruitions, based, not on the immediately prior attainment of jhāna, but, as in the instance of *sukkha-vipassanā*, on the basis of a skilful *Kāmāvacara* state. In answer to this it may be said that the limits within which supramundane realization can occur have been clearly defined, for in *Dhammapada*, verse 572, the Buddha says, "... There is no understanding without jhāna ...". On this basis, which jhāna gives its name to the grouping of jhāna constituents applicable to the instance in question?

639. Here, both *Atthasālini* and *Visuddhimagga*²⁴⁹ say that in accordance with the conditions governing the arising of insight, the supramundane Path arising to one of "dry insight" is of first jhāna only. This means that as in the first example of *Abhidhammatthasaṅgaha*, verse 38, there is "initial application," "sustained application," "zest," "mental pleasure" and "one-pointedness." Such is the characteristic structure of first jhāna. Thus, although *sukkha-vipassanā* has a skilful *Kāmāvacara* state as its "stepping off point," its Path of realization is structurally comparable with first jhāna.

640. While still on the subject of Path and Fruition states of the structure of first jhāna, it should be said that both the works mentioned add that the same applies to one who, although

²⁴⁹ See Exp. p. 307 and Ppn. p. 779, par. 112.

possessed of the ability to practice Mahāggata states, does not make jhāna the actual basis from which realization is made. Such is also the case for one who does make use of first jhāna as the basis.

641. With the completion of the fortyfold enumeration of supramundane states, Abhidhammatthasaṅgaha, in verse 41, summarizes as follows:

VERSE 41

JHAN AÑGA-YOGA-BHEDENA
KATV EKEKAN TU PANCADHĀ
VUCCAT-ĀNUUTTARAM CITTAM
CATTALĪSA-VIDHAN TI CA

Meaning:

HAVING NOW RENDERED (*katvā tu*) EACH ONE (*ekeka*) FIVEFOLD (*pañcadha*) IN ACCORDANCE WITH THE TYPES (*bhedena*) of JHĀNA CONSTITUENT COMBINATIONS (*jhāna + aṅga-yoga*), IT IS SAID THAT (*vuccati*) UNSURPASSABLE (*anuttara*) CONSCIOUSNESS (*citta*) is IN THIS WAY (*iti*) FORTYFOLD (*cattalīsa-vidha*).

642. Because of their close association and the similarity of structure existing between the Mahāggata states and the Lokuttara states, the first stanza of Abhidhammatthasaṅgaha verse 42 shows how, for the purposes of identification, the four supramundane Paths and their Fruitions are prefixed by the names of the five basic Mahāggata states. It also shows how, for the purposes of calculation, the Rūpāvacara and Arūpāvacara jhānas together form the five bases and structural details upon which the fortyfold supramundane system is developed.

VERSE 42 (Stanza 1)

643.²⁵⁰ YATHA CA RUPĀVACARAM
GAYHAT ĀNUUTTARAM TATHA
PAJHAM ĀDIJJHĀNA-BHEDE
ARUPPAN CA PI PANCAME

Meaning:

IN THE MANNER OF (*yathā*) states CHARACTERISTIC OF THE PLANE OF FORM (*Rūpāvacara*), SO LIKEWISE (*tatha*) THE "UNSURPASSABLE" (*anuttara*) states ASSUME (*gayhati*) THE CATEGORIES (*bhede*) of FIRST JHĀNA (*pathama-jhāna*) AND SO ON (*adi*); IN THE FIFTH (*pañcame*) jhāna THE FORMLESS (*aruppa*) states are ALSO (*cā pi*) included.

644. Having shown these relationships the second stanza of verse 42 specifies the numbers of integral conscious states, mundane and supramundane that can be collected together under the individual names of the five basic jhānas. An explanation of what is somewhat tersely stated in this stanza is as follows.

645. Recognizing that the five basic jhānas are indicated by individual numbers, for the reason that each represents a different and thus completely separate grouping of JHĀNA CONSTITUENTS (*jhānaṅgani*), this stanza as a continuation of the first section shows how many times each individual jhāna is included within the one hundred and twenty-one fold classification of states. It can be analyzed as follows:

²⁵⁰ See chart 13.

In the entire group of Rūpāvacara states, jhānas one, two, three and four each appear three times, that is, as a good (productive) state, as a resultant state and as an inoperative state. Consequently it is said that each individual jhāna appears 3 times.

In addition to this, because each of the four jhānas can, as is appropriate, participate in the arising of the four Path and four Fruition states, it is shown in the classification of supramundane states that each jhāna appears 8 times.

Thus amongst those one hundred and twenty-one states as a whole, each of the four jhānas appear 11 times.

The fifth jhāna, because of its association with the Arūpāvacara states, is calculated differently, thus: Amongst the Rūpāvacara and the supramundane states the fifth jhāna follows the same pattern as the four preceding jhānas, consequently it appears 11 times.

However, because of its appearance as a good (productive) state, as a resultant state and as an inoperative state in each of the four Arūpāvacara categories it appears a further 12 times.

Thus amongst the one hundred and twenty-one states as a whole, the fifth jhāna appears 23 times.

VERSE 42 (Stanza 2)

646. EKĀDASA-VIDHAM TASMĀ
PATHAM ĀDIKAM ĪRITAM
JHĀNAM EKEKAM ANTE TU
TEVĪSATI-VIDHAM BHAVE

Meaning:

ACCORDINGLY (*tasmā*) BEGINNING WITH (*adika*) FIRST JHĀNA (*pathama-jhāna*) ELEVEN (*eka dasa*) DIVISIONS (*vidha*) HAVE BEEN STATED (*īrita*) for EACH ONE (*ekeka*); IN THE LAST (*ante*) HOWEVER (*tu*) THERE SHOULD BE (*bhave*) TWENTY-THREE (*tevīsati*) CLASSES (*vidha*).

647. With verse 43 and a following closure line, comes the end of chapter one of Abhidhammatthasaṅgaha, CONSCIOUSNESS (*citta*). In that stanza are given new figures for the numbers of integral states included under the headings of meritorious, i.e., good, skilful, productive states, and resultant. These figures apply only where the basis of one hundred and twenty-one is used. For comparison with the appropriate values where the basis of eighty-nine is applicable, verses 35 and 36 should be consulted.²⁵¹

VERSE 43

648. SATTATIMSA-VIDHAM PUNNAM
DVIPANNASA-VIDHAM TATKĀ
PAKAM ICCĀHU CITTĀNI
EKAVĪSASATAM BUDHA.

Meaning:

THIRTY-SEVEN (*sattatimsa*) CLASSES (*vidha*) of MERITORIOUS (*punna*) ALSO (*tatha*) FIFTY-TWO (*dvipannāsa*) CLASSES (*vidha*) of RESULTANTS (*pāka*); THUS (*iti*) THE WISE (*budhā*) HAVE SAID (*āhu*) there are ONE HUNDRED AND TWENTY-ONE (*ekavīsasata*) integral CONSCIOUS STATES (*cittāni*).

ITI ABHIDHAMMATTHASANGAHE CITTASANGAHAVIBHĀGO NĀMA PATHAMO
PARICCHEDO

²⁵¹ See pars. 603-606 inc.

Meaning:

Thus is the first chapter of Abhidhammatthasaṅgaha, entitled An Analytical Summary of Consciousness.

ABHIDHAMMATTHASAṄGAHA Talk No. 11 (Part 2)

649. With the completion of Chapter One of Abhidhammatthasaṅgaha, and thereby of discussion of all categories of integral conscious states, a point has been reached from which it is possible to make a general survey. However, in order to do so it is necessary to have a starting point. In this instance the point chosen is causality, which in view of the practical nature of the Buddha's Teaching is quite appropriate, for when consideration is given to such matters as roots, resultants, the four Noble Truths, the causal series of paṭiccasamuppāda, the Noble Eight Constituent Path and so on, it is evident that each such group demonstrates the principles of causality to the highest degree.

650. This is not just a matter of scholastic interest, but is an important aspect of the Buddha's Teaching in that it emphasizes the necessity for mindfulness, and thus for discrimination in respect of all three classes of action. Where there is disregard for the knowledge that ACTION (*kamma*) is causative of RESULTANT (*vipāka*), there exists a consequent lack of discrimination in actions performed. There being such absence of mindfulness, progress towards the development of penetrative insight cannot take place.

651. That the importance of the causal principle was taught by the Buddha from the very beginning of his ministry, is shown in a single stanza, the recitation of which was a contributory cause towards the ordination of two bhikkhus who later became the Buddha's chief disciples. A brief history of the occasion is as follows²⁵²

652. At a time when neither Sāriputta nor Moggallāna had yet come into contact with the Teaching of the Buddha, the two friends (sometimes known as Upatissa and Kolita respectively) were staying near to the city of Rājagaha. Being at that time pupils of the itinerant teacher Sancaya (Sañjaya), both were seeking to gain insight under his guidance. In this situation the two agreed between themselves that whichever should first attain to that "deathless" state, he should speak of it to the other.

653. Sometime later Sāriputta was particularly impressed by the deportment and demeanour of a holy man he observed making his alms round. Later, he approached him, and politely mentioning the purity and clarity of his appearance inquired as to his reasons for adopting the religious life, asking who was his teacher or to whose teaching did he accede. As it so happened this holy man was one of the Buddha's initial group of five disciples; Bhikkhu Assaji was his name, and he answered thus, "There is, friend, a great recluse, a son of the Sakyas, gone forth from a Sakya family. On account of that Exalted One I have undertaken the life of a bhikkhu; moreover, that Lord is my teacher, and I accede to that Lord's teaching." Asked then by Sāriputta to speak further of this teaching, Bhikkhu Assaji replied that being but newly ordained he was able to expound only in brief. Sāriputta assenting to this, Bhikkhu Assaji pronounced this renowned and revealing stanza:

"YE DHAMMĀ HETUPPABHAVĀ
TESAM HETUM TATHAGATO –
AHA TESANCA YO NIRODHO
EVAMVĀDĪ MAHĀSAMANO" TI

Meaning:

Things which come to be by way of cause, of those the Tathagatha has stated the cause and that which is their cessation. The Great Recluse is the One teaching such a doctrine.

²⁵² See Vin., Mahāvagga, Book of the Discipline, Part IV, pp. 52-56.

654. Hearing this concise declaration of that doctrine, there arose, fully apparent to Sāriputta, penetrative insight into the fundamental principle that “whatsoever is subject to arising, all such is subject to cessation.” Going then to visit Moggallāna in accordance with their agreement, he repeated to him Assaji’s stanza; whereupon, as with his friend, there arose to Moggallāna the same penetrative insight that “whatsoever is subject to arising, all such is subject to cessation.”

655. With the realization of this law, both decided that the time had arrived for them to become pupils of the Buddha. Therefore, departing from Sancaya and approaching the Buddha, they said, “May we, Ven. Sir, in the Blessed One’s presence, receive the ‘going forth’, may we receive ordination?” “Come, Bhikkhus,” the Lord said, “Rightly proclaimed is the Dhamma; practice the supreme practice for making a complete end of suffering.” In this way Ven. Sāriputta and Ven. Moggallāna became bhikkhus.

656. In this short history the key passage is the stanza itself, and within that the words, “Things which come to be by way of cause, of those the Tathagatha has stated the cause and that which is their cessation ...” As it stands this is a general statement, and because of that needs to be examined further in order to discern its deeper implications. The Commentary to the Mahāvagga of the Vinayaṭaka²⁵³ sheds light on this straight away, by saying that the things which “come to be by way of cause” are the FIVE AGGREGATES (*pañcakkhandha*); i.e., the AGGREGATE OF MATERIAL QUALITIES (*Rūpakkhanda*), the AGGREGATE OF FEELING (*Vedanakkhandha*), the AGGREGATE OF PERCEPTION (*Sannakkhandha*), the AGGREGATE OF MENTAL CONCOMITANTS CO-ORDINATED BY VOLITION (*Sañkharakkhandha*) and the AGGREGATE OF FACTORIAL CONSCIOUSNESS (*Viññānakkhandha*).

657. These aggregates have already been spoken of as the “building bricks” constituting the so-called being.²⁵⁴ As a general statement this is quite correct, nevertheless it does in a certain sense present a limited and perhaps even a slightly misleading view inasmuch as it could give rise to the idea that each individual aggregate is a “something,” steady and reliable and possessed of permanence and stability, at least while a life span persists. Nothing could be further from the truth, for, instead of being stable entities, each aggregate represents only a convenient heading or category under which a single observable quality, or collection of observable qualities, may be included in such a manner that their differences of nature and function may be readily perceived.

658. But what of the individual qualities so represented? In Abhidhammatthasaṅgaha, more particularly in chapters two and six, they appear as lists of attributes, accordingly as they refer to mind or to matter. As they occur performing their individual functions, however, the many qualities and conditions so named point to the presence of definable, but none the less transient—and thus ever changing and impermanent—phenomena, which, in appropriate association constitute the entirety of mental and material occurrence. In an ultimate sense, therefore, when these two general terms, mind and matter, are made use of, they refer to the coming to be and passing away of qualities appropriate to the particular mental or material occurrence apparent at that time.

659. But now to examine those two groups in order to define their individual contents. When one speaks of mind, referring thereby to the entire process of thought, and thus to the arising of individual integral conscious states, or to groupings or series of such states, the meaning in Abhidhamma terms centres upon the factorial consciousness present at a particular instant, and to the appropriate mental concomitants attendant upon it. These, taken as a whole, can then be

²⁵³ C.S., Samantapāsādikā, Mahāvaggavaṇṇana, p. 256.

²⁵⁴ e.g., pars. 136 & 192.

grouped according to their similarity or dissimilarity of function, but all as items capable of aggregation into specific structures, in this instance integral conscious states.

660. As has already been seen, factorial consciousness means nothing more nor less than the existence of a basic awareness of an object, be that object material or ideational. Because of this uniqueness of function such awareness stands in a category of its own. In this mode of classification it is therefore known as the AGGREGATE OF factorial CONSCIOUSNESS (*Viññānakkhandha*).

661. The classification of mental concomitants, of which only a small number are mentioned in chapter one, is, however, somewhat more complex. For example, FEELING (*vedanā*), which has been shown to be divisible into five classes²⁵⁵ invariably arises simultaneously with consciousness. Indeed, there is no consciousness without the presence of feeling, and there can be no feeling without the presence of consciousness. However, as feeling, pleasant, painful, or neutral, is quite different from "awareness of an object," it is necessary that it also should be classified separately so that this difference may be apparent. It is therefore categorized as the AGGREGATE OF FEELING (*Vedanakkhandha*).

662. Another concomitant quality invariably present with the arising of consciousness is PERCEPTION (*saññā*). This is the quality which perceives the GENERAL CHARACTERISTIC (*lakkhana*) of the object of which consciousness is aware. As with the association between feeling and consciousness, so is it with perception and consciousness. Thus there can be no awareness without the simultaneous presence of the recognition of the "characteristic mark" of the object of that awareness. Similarly it is not possible for there to be any such recognition without the presence of consciousness; thus, although dissimilar, they always arise together. In consequence of this, since perception is a quite different quality from either awareness or feeling, it likewise stands in a separate category known as the AGGREGATE OF PERCEPTION (*Sannakkhandha*).

663. In its second chapter Abhidhammatthasaṅgaha enumerates a total of fifty-two mental concomitants, a total which includes the concomitants of feeling and perception just mentioned. There remain, therefore, a further fifty yet to be classified in terms of aggregates. However, despite their wide differences of character, these fifty form a single group when centred around the very particular qualities of one of their number known as VOLITION (*cetanā*).

664. Volition in common with feeling and perception invariably arises together with consciousness, thus there can be no consciousness without the simultaneous presence of volition, and no volition without the presence of consciousness. Volition, however, represents not only the intention to act in a particular manner, but also the ability to exercise that intention. Because of this, volition, as a concomitant quality, represents great zeal and enthusiasm to act, and in consequence draws other concomitants into the sphere of its influence, co-ordinates their individual qualities, and, while itself acting, directs them to its purpose. In this way action of the three classes is implemented, and, as the outcome of such action, there is an appropriate resultant. From this it is apparent that volition performs a most important function in co-ordinating the concomitant qualities, particularly in the second phase, i.e., in the resultant producing phase of the conscious process.

665. Since all the remaining concomitants are subject to, and operate together with volition, they are classified as a single group. The Pali word employed to describe this group is *saṅkhāra*, for as a word it signifies not only the compounded or "built-up" structure of the group as a whole, but suggests at the same time the multiplicity of activities productive of resultant. Here it

²⁵⁵ See par. 77.

should be mentioned that in view of this complexity and the diversity of transient qualities classified under a single heading, it is not to be supposed that with each arising of consciousness the entire fifty concomitants also arise. On the contrary, on any given occasion the only qualities which come to be and pass away are those which in appropriate association with consciousness constitute an individual integral conscious state.

666. In translation this group has been known variously as the confections, the synergies, formations, volitional activities, etc., names, all of which have the advantage of brevity. However, in order to show the characteristic co-ordinating, volitional and directing forces to which as a group these concomitant qualities are subject, they are here referred to as the AGGREGATE OF MENTAL CONCOMITANTS CO-ORDINATED BY VOLITION (*Saṅkharakkhandha*).

667. In this way (factorial) consciousness and all mental concomitants are capable of being categorized within a system of four aggregates, as follows: Aggregate of Feeling, Aggregate of Perception, Aggregate of Mental Concomitants co-ordinated by Volition and Aggregate of Consciousness.

668. To reduce this still further, these four, when considered as a whole, are referred to as the AGGREGATE OF MENTAL QUALITIES (*Namakkhandha*). Moreover, when in Abhidhamma terminology the word “*nāma*” is used by itself to mean “mind” or “mental qualities,” it refers directly to the four mental aggregates, and thereby to consciousness and the fifty-two mental concomitants.

669. MATTER or MATERIAL QUALITY (*rūpa*), being one of the four ULTIMATES (*paramattha*), is in every way separate and distinct from the three Ultimates comprising MENTAL QUALITIES (*nāma*). In consequence, matter cannot be expressed in terms of the other three Ultimates, i.e., consciousness, mental concomitants, or Nibbāna. However, just as integral conscious states can be analyzed as appropriate combinations of transient mental qualities, so matter can be analyzed in terms of transient material qualities.

670. The various factors constituting matter as a whole are not discussed here, that being the main subject of the sixth chapter of Abhidhammatthasaṅgaha. For the purpose of identifying the material aggregate, however, it should be said that there are four fundamental material qualities known as THE FOUR GREAT ESSENTIALS (*cattari mahābhūta*), which in their coming to be and passing away give rise, as is appropriate to the conditions, to twenty-four so-called DERIVED MATERIAL QUALITIES (*upadaya rūpa*). In all, therefore, twenty-eight discrete factors constitute the AGGREGATE OF MATERIAL QUALITY (*Rūpakkhanda*).

671. That completes the enumeration of the five aggregates defined by the Commentary as states which “come to be by way of cause.” In accordance with this it is evident from analysis of that which comprises the four mental aggregates, and the single material aggregate, that whatsoever “comes to be” in those all-inclusive fields, be it mental or material, does so “by way of cause,” and is ultimately resolvable into relevant associations of causally originated constituent mental or material qualities.

672. In explaining the stanza spoken by Ven. Assaji, the Commentary has a deeper purpose than pointing only to the causal origin of the five aggregates, for it then proceeds to say that accordingly as they come to be so the TRUTH OF SUFFERING (*dukkha-sacca*) is apparent. What is meant by the Truth of Suffering?

673. Suffering, i.e., *dukkha*, is a term very difficult indeed for which to find a satisfactory single English equivalent. Its more customary values of suffering, pain and unsatisfactoriness,

although quite suitable in many contexts, do in effect only skirt round its deeper, yet at the same time far more revealing implications; in order, therefore, to become aware of these its derivation has to be examined. According to the explanation given in *Visuddhimagga*²⁵⁶ *dukkha*, as a word, consists of two parts, viz. DU + KHAM. The first is a simple prefix meaning odious, bad, and contemptible. The second part, *kham*, means emptiness or empty space, thereby implying either worthlessness or, as is the case with waste land or desert, an area fraught with danger. Combining these two parts, *dukkha* is resolved as having the two fundamental connotations of being odious, in that it is fraught with danger, and odious in that it is barren and worthless in respect of the opinions held by deluded people regarding permanence, beauty, pleasure and individuality. In consequence of this, when, with the coming to be of the aggregates, the Commentary says that *dukkha* is apparent, it signifies not only that the aggregates themselves represent exactly the characteristics of *dukkha* but that those aggregates, being transient, are thereby worthless and not to be relied upon. Moreover, in that they are directly engaged as constituting the very states which maintain the continuity of the self-perpetuating cycle of rebirth, ageing, and death, they represent an area fraught with danger. Thus it is that in terms of making progress towards gaining penetrative insight, the five aggregates constituting the entirety of the so-called being are groups to be understood as they really are and thereby despised as the embodiment of suffering.

674. Having spoken of things that "come to be by way of cause," the stanza of Ven. Assaji continues by saying, "Of those the Tathagatha has stated the cause and that which is their cessation." The Commentary, having already shown that the arising of the aggregates is synonymous with suffering, then explains in accordance with the Buddha's words that the cause of the aggregates is therefore synonymous with the cause of suffering. Since throughout the Piṭakas it is repeatedly shown that CRAVING (*tanhā*) is the CAUSE OF SUFFERING (*dukkha-samudaya*), it is thereby evident that craving is the cause of the coming to be of the aggregates.

675. The statement of a causal relationship such as this is clearly of considerable importance, for with the identification of craving as cause, it illustrates by way of suffering and the cause of suffering how the four Noble Truths are directly interconnected with the causal series of *paṭiccasamuppāda*. This is again strongly reinforced by the simultaneous mention of the aggregates, for it is these, which, in their analysis, provide the mental qualities and the material qualities forming the substance of that causal series.

676. In respect of craving and the coming to be of aggregates, it therefore calls to mind that which was said earlier of the way in which, because of CRAVING (*tanhā*) for pleasant feeling, there arises ATTACHMENT (*upādāna*) as a potentiality to retain or reject the object of craving, and how this is followed by ACTION CUMULATIVE OF RESULTANT TENDING TOWARDS REBIRTH (*bhava*).²⁵⁷ Here it is well to observe that with the mention of even only these three stages of *paṭiccasamuppāda* there is illustrated in terms of object of sense, craving and the integral conscious states involved, how all the five aggregates participate in the causal series.

677. To turn for a moment to the integral states themselves, and to their relationship as aggregates to the causal series. Here it must be said that in respect of the bringing about of rebirth tendency due to the activity of craving, it cannot be stressed too strongly that the twelve unskilful states rooted in greed, hatred, and delusion, are by no means the sole medium by which this takes place. On the contrary, other integral conscious states are equally responsible. This is because where ultimate penetrative insight has not been achieved, such states are tied

²⁵⁶ Ppn. p. 563 & P. Purity p. 586.

²⁵⁷ See pars. 116 ff.

and bonded to the repeated cyclic sequence of rebirth and death; being submerged therein by attachment to desire for sense pleasure, to wrong views, to wrong habits and practices and by attachment to the idea of soul. Thus, for example, the good (productive) states, whether Kāmāvacara, Rūpāvacara, or Arūpāvacara, being completely mundane, are inherently subject to all these attachments and to the many other corrupting influences. Because of this their activity is just as productive of resultants tending towards rebirth as is that of the unskilful states, the difference being apparent in the conditions of rebirth.

678. Thus it is that where there is ignorance and craving, together with the many corrupting influences dependent upon them, there comes about the arising of the aggregates as their active manifestation. Since these aggregates constitute the entirety of the so-called being, that being is maintained so long as ignorance and craving persist. What, then, is the cessation of those things which come to be by way of cause, spoken of by the Buddha and referred to in the stanza of Ven. Assaji?

679. Cessation points directly to the third of the four Noble Truths, viz., the TRUTH OF THE CESSATION OF SUFFERING (*dukkha-nirodha-sacca*). This cessation, as the Commentary shows, is the coming to an end of two things-, i.e., suffering and the cause of suffering. This, transposed into parallel terms, means bringing to an end the aggregates constituting the so-called being, and bringing to an end their cause, craving. However, as cessation clearly refers to the completion of a process, what in practical terms can be said to lead up to that conclusion?

680. The answer to this lies in the fourth Noble Truth, i.e., THE WAY LEADING TO THE CESSATION OF SUFFERING (*dukkha-nirodha-gamini-paṭipadā*). This, as it stands, is a plain statement, for without giving any details it constitutes a straightforward indication that the cessation of suffering is indeed a practical possibility. It is, therefore, the detailing of the parts constituting that “way” which present the actual course to be undertaken in order that the dual combination of suffering, and the cause of suffering, may be brought to an end.

681. The “way” itself is the Noble Eight Constituent Path, comprising Right View, Right Thought, Right Speech, Right Action, Right Livelihood, Right Effort, Right Mindfulness and Right Concentration; which, as previously mentioned, can be resolved into three basic aspects, viz., moral practice, mental development and wisdom. These three are of the greatest possible importance, for it is only by achieving a proper balance between them in terms of the individual path constituents that supramundane penetrative insight is to be realized.

682. With the achievement of just such a proper balance, what is signified by the realization of supramundane conscious states, states which have but a single object, Nibbāna, the unconditioned element? Such states signify the development of penetrative insight which recognizes the “built-up,” compounded and conditioned nature of objects of sense and mind, and of the conscious states themselves constituting awareness of, and attitude towards, those objects; in a word, the recognition of those conditions as applying directly to the five aggregates, mental and material.

683. With the recognition of the compounded and conditioned nature of things, such states signify the development of penetrative insight into the impermanence inherent in such structures, and thus, in an ultimate sense, of the utter futility of attachment in respect of them.

684. Again, such states signify the development of penetrative insight into the suffering occasioned by any such attachment, inasmuch as, in an ultimate sense, those compounded and conditioned things are empty, and, like a desert concealing hidden perils, are fraught with danger.

685. Again, such states signify the development of penetrative insight into the knowledge that beyond the seeming reality of compounded and conditioned things, and beyond their component structures in terms of mental or material qualities, there exists no essence, no self-nature, and no soul which in an ultimate sense can furnish them with reality, permanence or any enduring quality whatsoever.

686. To the extent, therefore, that the four supramundane paths realize first the impermanence, suffering and absence of soul in whatsoever is compounded and conditioned, and, based on that, make an end of craving and ignorance, so does there become apparent the absolute stability and absence of strife characterized by that which is neither compounded nor conditioned, and wherein is neither craving nor ignorance.

687. In this connection, and concluding what has been said of but a fraction of the implications of Ven. Assaji's stanza, it is opportune to observe the outcome of its having been heard by both Ven. Sāriputta and Ven. Moggallāna. In reporting the occasion the Vinaya states that, "... there arose, free from defilement, free from stain, insight into the reality that whatsoever is subject to arising, all such is subject to cessation." This realization, with its specific mention of arising and cessation, is, however, not just an expression of mundane recognition of the principle of impermanence. On the contrary, it represents here the instants of supramundane penetrative insight based on full realization of IMPERMANENCE (*anicca*), SUFFERING (*dukkha*), and ABSENCE OF SOUL (*anattā*). It therefore constituted for both Ven. Sāriputta and Ven. Moggallāna the instant of attainment of the PATH OF STREAM ENTRY (*sotapatimaggā*), the instant at which, for the first time, there is awareness of that which is not compounded, which is utterly unconditioned and is devoid of ignorance and craving; Nibbāna.

688. In discussing this first chapter of Abhidhammatthasaṅgaha one thing only has been achieved in its entirety, which is the enumeration of integral conscious states in accordance with the eighty-nine and one hundred and twenty-one fold systems detailed in the books of the Abhidhamma Piṭaka. Apart from this, however, many other conditions and qualities have been spoken of in order to bring to notice the manifold laws and factors influencing the existence and functions of those integral states. Here, though, it should be said that few of these additional matters have been treated in any exhaustive sense, primarily because they belong properly to later chapters, and secondarily because in most cases their scope extends far beyond the immediate requirements of this present stage. In the instance of Ven. Assaji's stanza, rather more attention has been paid, for it has been a means whereby the very important subject of the five aggregates could be formally introduced, and at the same time as a way of pointing to several other equally important relationships clearly involving the activities of conscious states.

689. Thus it is that because of the introduction of such additional material into the process of describing the various classes of consciousness, it has been possible to show how—because of ignorance and craving—there are "roots," "fetters," "hindrances," "latent tendencies" and many other undesirable qualities, all of which in accordance with the causal series of paṭiccasamuppāda are intimately concerned with the coming to be and resultants of conscious states.

690. As has been seen, mundane integral states, be they Kāmāvacara, Rūpāvacara or Arūpāvacara, are all affected directly or indirectly, as is appropriate, by aspects of ignorance and craving, and are in consequence productive of rebirth conditions. Moreover, no matter to which sublime, but nevertheless still mundane, levels rebirth may attain, the power of ignorance and craving continues unrelentingly to draw existence to ever lower and lower levels. It is only when supramundane penetrative insight has been achieved that the power of ignorance is first curtailed and finally eradicated.

691. In connection with this unrelenting pull of ignorance, and its direct relationship with bad states, the following question naturally arises; why are the twelve unskillful states looked upon as being weak, when in their effect of maintaining unhappy rebirth conditions they appear to be so very strong?²⁵⁸

692. Some explanation of this may be apparent when further consideration is given to the nature of beings and to the forces responsible for their existence. Beings, so-called, as has been seen, are but cognizable conglomerates of the five aggregates, aggregates causally bonded by ignorance and activated by the craving associated with that ignorance. To that extent, therefore, beings and the courses they follow are to a greater or lesser degree the product of ignorance in its technical *Abhidhamma* sense of absence of awareness of the true nature of things. Consequently bad states, and thus the aggregates they constitute, being already close to ignorance, remain there without the need of major resultant states to maintain that condition. They are, in consequence, looked upon as weak.

693. On the other hand, states—and thus the aggregates and beings they comprise which with great effort strive to oppose ignorance and craving, minimize their effect by creating major rebirth resultants which take effect in rebirth conditions further removed from the direct influence of ignorance. By virtue of this effort and striving, therefore, such states are said to be strong.

694. Earlier, when discussing the repetitive cyclic sequence of rebirth and death, a simile for the existence of a being made use of the idea of a vortex motivated by craving in the ambience of ignorance.²⁵⁹ Now, in conclusion, that same simile in somewhat modified and expanded form is used yet again, this time to illustrate that from the very nature of its operative structure, and quite irrespective of the plane in which it may occur, conditioned existence cannot in itself be modified so as to render it free from the danger and suffering inherent in it. The individual may perform good works to help others; moreover, the suffering of those others may to a greater or lesser degree be alleviated in the short term. However, the only criterion for the gaining of final freedom from such danger and suffering is the cultivation by the individual himself of moral practice, mental development and penetrative wisdom; penetrative wisdom such as transcends the conditioned and realizes the unconditioned.

695. Initially the simile introduces to the mind's eye a large circular lake bounded by a golden shore, but having at its centre a powerful, sinister, and ever-turning whirlpool. In considering this scene the outstanding feature is the shore of smooth golden rock; clean, bright and stable, and quite unaffected by the water. At the edge the water is clear and calm, remaining so for a little distance out. Beyond this it circulates slowly, but with increasing speed as it approaches the centre. With this turbulence the water becomes increasingly murky until at the very centre it is quite opaque, and revolving rapidly as to create a saucer depression and tunnel-like vortex, sucking and drawing all to the depths below.

696. In this first part of the simile, which is intended as a picture of existence as a whole, the water represents ignorance, i.e., absence of awareness of the four Noble Truths concerning suffering. The circulation of the water represents the actual cause of that suffering, i.e., craving. The vortex, inasmuch as it shows ignorance and craving in their most direct and powerful manifestation, represents the way leading to those conditions of existence wherein there is the greatest opacity to understanding, and thus the least likelihood of its arising.

²⁵⁸ See par. 200 ff.

²⁵⁹ See par. 575.

697. The shore of smooth golden rock, as the antithesis of ignorance and craving, represents that which is stable, pure and unmoving, that which is aloof from and utterly unconditioned either by ignorance or craving. In this simile, therefore, it signifies the highest penetrative understanding, constituting thereby that which is the end of suffering, Nibbāna. Consequently the steadily decreasing murkiness and slackening in rotation of the water from vortex to periphery is intended to illustrate how, with the systematic dispersal of absence of awareness of the four Noble Truths, the inward drag towards the vortex of ignorance and craving, although omnipresent, becomes less and less effective.

698. The continuation of the simile involves a closer examination of the lake. Here, over its entire surface, but more densely as the centre is approached, are to be observed myriads of minute whirlpools. These are the by-product of the turbulence of the moving waters, and where that movement is most active, so the little whirlpools, or eddies, are the deepest and most pronounced. Moreover, as by the increasing rotation they come within the direct influence of the vortex they move rapidly inwards, slip over its edge and are quickly drawn down through the central tunnel.

699. Beyond a certain distance from the most dangerous areas, however, these little eddies behave differently, some still moving towards the centre; some, though still spinning strongly, moving very little, and a few even moving outwards. Those moving inwards increase in depth, and become more marked in their activity, while those moving towards the periphery spin less rapidly and thus become shallower and less well defined. The very few which spin into the fully calm area at the outer reaches, rapidly lose their appearance of being eddies and, one by one abandoning all residual impetus of turbulence, disperse completely as they reach the edge of the smooth golden shore.

700. In this latter half of the simile the little whirlpools, or eddies, resulting from and existing as part of the turbulence of the lake's swirling waters, represent beings existing as the product of the turbulence of ignorance and craving, and as dwelling at all times within that sphere of influence. Thus eddies that are deeper and more pronounced represent beings in whom "wrong view" is strong, and where the practice of unskillful states is prevalent. Consequently those eddies which come within the direct influence of the vortex, and are thus drawn to the depths, represent beings who, because of a dominance of evil view and practice, fall to low, unhappy states of rebirth, where it is exceedingly difficult for understanding of the true nature of suffering and its cause to arise. This again illustrates the inherent weakness of unskillful states, in that they present no opposition whatsoever to the power of ignorance and craving.

701. Eddies which in the less turbulent waters move little, or which even move outwards, represent beings who, without necessarily having any true realization of the way leading to the cessation of suffering, nevertheless oppose ignorance and craving by way of the skilful states of moral practice and mental development. However, such beings, though highly moral and perhaps possessed of great ability in concentrating the mind, still exist within the active compass of the great whirlpool of existence, and are thus constantly in danger of being drawn towards its centre vortex.

702. Those few shallow eddies which spin gently from the rotating water and gain the fully calm untroubled area, represent beings who, in addition to moral and mental development, have gained wisdom; wisdom that is the supramundane penetrative insight constituting the Path and Fruition of stream-entry. Even so, comparable with the eddies existing and moving in the calm waters free from murkiness, those beings exist as still lightly motivated by craving and moving within the ambience of residual ignorance. They have, however, reached a point from which they can never more be drawn back into the great whirlpool of repetitive rebirth and

death—saṃsāra. As beings they are those who, by their subsequent systematic realization of the remaining three supramundane Paths and Fruitions, can yet again be compared with the eddies quickly, or less quickly, waning and flattening out in the calm water, in that they rapidly, or less rapidly, abandon all residual impetus from the turbulence of ignorance and craving and reach its absolute finality as they attain the smooth golden shore that is Nibbāna.

APPENDIX

ON THE COURSE OF CONSCIOUS PROCESS, See also Chart No. 16

In the course of discussing the first chapter, mention has been made on several occasions of the course of conscious process. Reference was made to general points concerning the several different functions performed by specific integral conscious states, extending from the moment of initial contact with an object of sense, and through the subsequent successive stages up to the cessation of “full awareness.” Very little technical detail was included though, as the whole subject of the process of cognition belongs properly to chapter four of Abhidhammatthasaṅgaha, and presupposes a sound knowledge, of the first three chapters; however, as a certain degree of additional knowledge may well be helpful to gaining a better understanding of chapter one, some further material is given below.

This consists of an expanded translation of a short section of the fundamental Commentary to Abhidhammatthasaṅgaha, entitled Abhidhammatthavibhavini. The explanation comprises a somewhat fuller version of a simile taken from Atthasālini, entitled The Mango Simile (*ambopamā*).²⁶⁰ In addition to this a chart is included, illustrating how the successive individual thought moments gradually build up the effective strength of the entire process to a peak of intensity in the period of “full awareness,” which is then followed by a rapid diminution of this intensity as the whole process reverts to the steady flow of the constituent potentiality of being, the passive state (*bhavaṅga*).

THE MANGO SIMILE

It is said that at the foot of a fruiting mango tree a certain man, having wrapped himself right up to the head, was sleeping nearby to where there fell a single mango fruit. Awakening because of the sound, then taking away the cloth from his head, he, opening his eyes and seeing the fruit, having taken hold of it, squeezed it, smelled it, and recognized its ripe condition, savoured it. Swallowing what had gone into the mouth, together with the saliva, he again went to sleep in that very same place.

In this connection the occasion of the man sleeping is like the time of the passive state, *bhavaṅga*.²⁶¹

The occasion of the falling of the fruit is like the striking of the sensitive surface of an organ of sense by a sense object.²⁶²

The occasion of awakening because of the sound made by the falling fruit is like the time of mentally “adverting” towards a sense stimulus, and thus away from and interrupting the passive state, *bhavaṅga*.²⁶³

The occasion of having opened the eyes and looked around is like the time of the occurrence of “eye-consciousness”²⁶⁴

The occasion of taking hold of the fruit is like the time of “receiving” the objective data.²⁶⁵

The occasion of squeezing the fruit is like the time of “investigating” that data.²⁶⁶

²⁶⁰ See Exp. p. 359.

²⁶¹ See par. 240 f.

²⁶² See pars. 214/215. See also Chart No. 16: 1. = atita-bhavaṅga; 2. = bhavaṅga-calana; 3 = bhavaṅga-upaccheda).

²⁶³ See pars. 238/239, also Chart: 4 = avajjana.

²⁶⁴ See pars. 213/217, also Chart: 5 = pañca-viññāṇa.

²⁶⁵ See par. 227, also Chart: 6 = sampaticchana.

²⁶⁶ See pars. 228/230, also Charts 7 = santirana.

The occasion of smelling, and thereby of recognizing the ripe condition, is like the time of “determining” the nature of the object.²⁶⁷

The occasion of savouring the fruit in the process of its being eaten is like the time of “full-awareness” of the object.²⁶⁸

The occasion of swallowing what had gone into the mouth together with the saliva, is like “reverting” towards the passive state, bhavaṅga, thereby bringing to a conclusion the active phases of conscious process.²⁶⁹

The occasion of sleeping once again is like having reverted to the passive state, bhavaṅga.

What, then, is made apparent by this simile?

1. That the role of the sense object is nothing more than the striking of the sensitive surface of an organ of sense.
2. That of “adverting” being nothing more than a mental inclining towards the doors of sense.
3. That of “eye-consciousness” being nothing more than mere “seeing.”
4. That of “receiving” and the others (i.e., “investigating” and “determining”) being nothing more than mere “taking in,” “investigating” and “determining.”
5. That of “full-awareness” alone, being the experiencing of the flavour of the object.
6. That of “reverting” to the passive state being merely the experiencing of the same object as that experienced by the preceding thought moment

In this way, because of their different roles, the separateness of the states from one another is made apparent.

NOTE: The paragraph references noted above refer to the foregoing discussion of consciousness.

²⁶⁷ See par. 243, also Chart: 8 = *votthabbana*.

²⁶⁸ See par. 189, also Chart: 9-15 inc. = *javana*.

²⁶⁹ See Chart: 16 & 17 = *tadārammaṇa*).

Charts

CONTINUED FROM CHART Nº 2
INTEGRAL CONSCIOUSNESS
 CHARACTERISTIC OF THE PLANE OF SENSE DESIRE
 (KĀMĀVACARA CITTA)

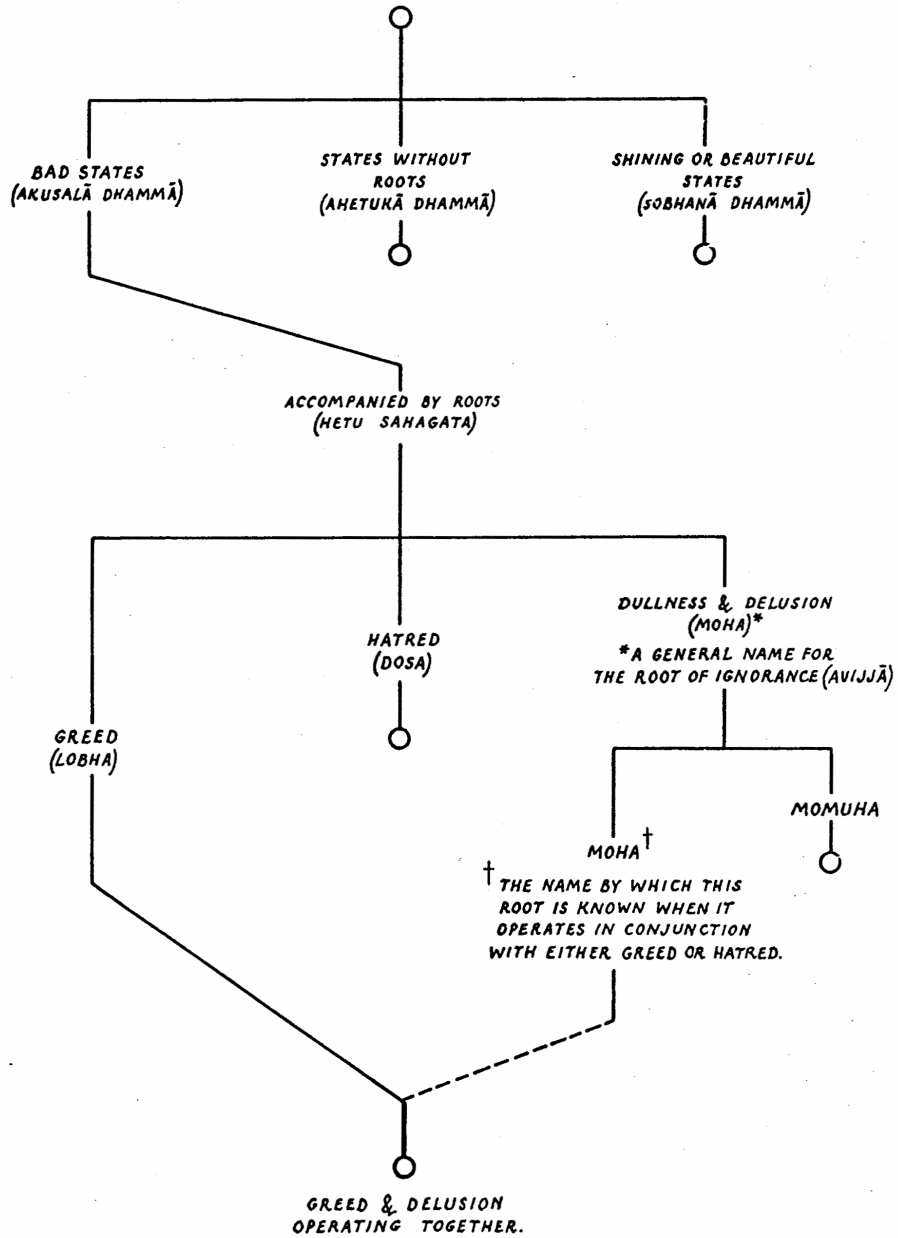
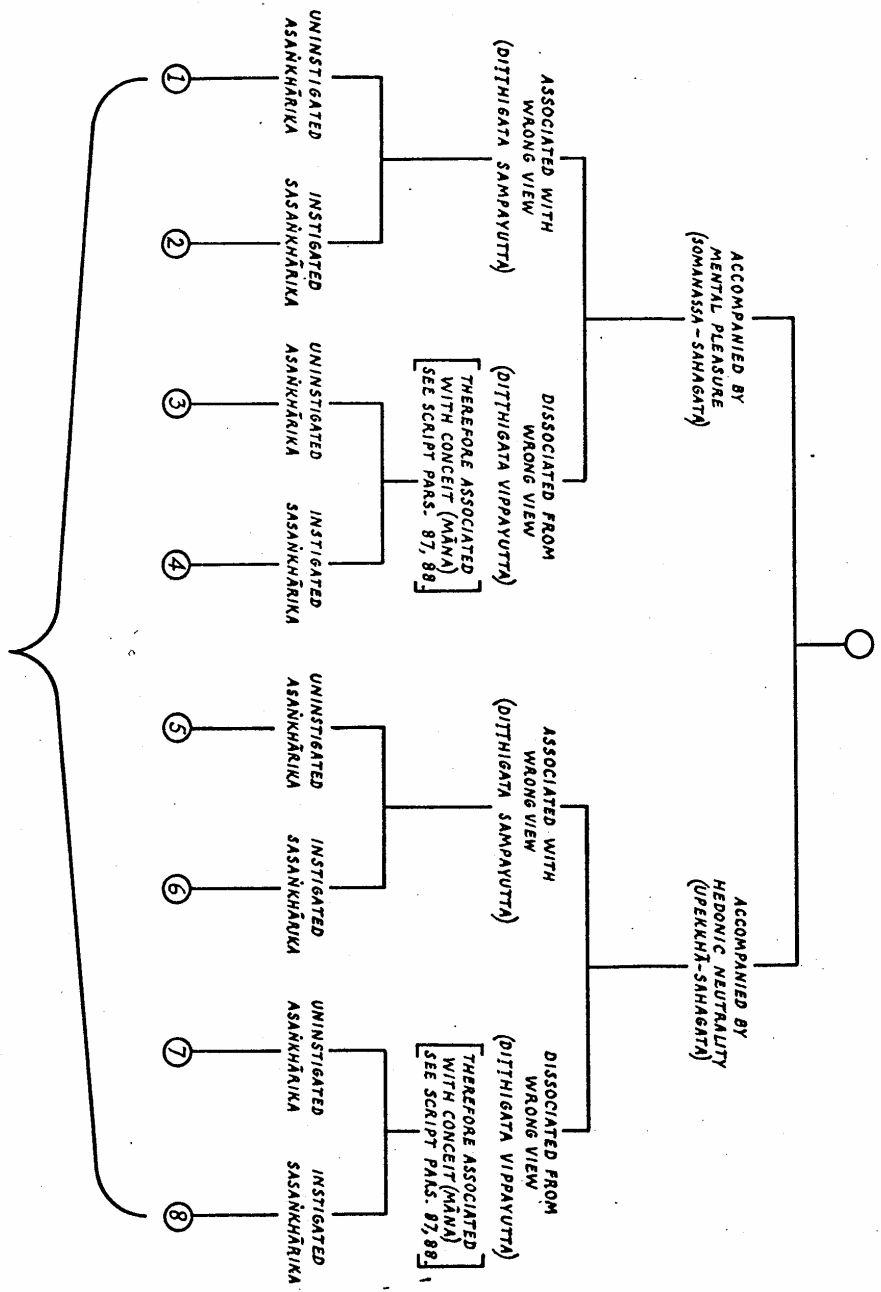

CHART Nº 3
 REF. SCRIPT PARAS. 63, 64, 75.

CONTINUED FROM CHART N° 3
 GREED (LOBHA) & DELUSION (MOHA)
 OPERATING TOGETHER



THESE EIGHT TOGETHER ARE KNOWN AS FACTORIAL CONSCIOUSNESS ACCOMPANIED BY GREED ~
 (MĀNI ATTHA-PI LOBHA-SAHAḠATA - CITANI MĀNA)

CHART N° 4
 REF: ABHI/S. VERSE 4 ALSO SCRIPT PARS. 67, 68, 87, 88.

FOUR ATTRIBUTES IN TERMS OF WHICH STATES ARE ANALYZED,
 EXAMINED AND COMPREHENDED IN THE COURSE OF ATTAINING
 TO
 PURITY OF VIEW
 (DITTHI-VISSUDDHI)

GENERAL CHARACTERISTIC

(LAKKHANA)

THE MOST ELEMENTARY
 DISTINGUISHING MARK
 BY WHICH A STATE
 CAN BE RECOGNIZED.

INHERENT FUNCTIONAL PROPERTY

(RASA)

THE INTRINSIC ACTIVE
 PRINCIPLE OF THE STATE.

RESULTANT APPEARANCE

(PACCUPATTIHAANA)

THE MANNER IN WHICH THE
 MATURED QUALITIES OF THE
 INHERENT FUNCTIONAL PROPERTY
 BECOMES APPARENT TO THE OBSERVER.

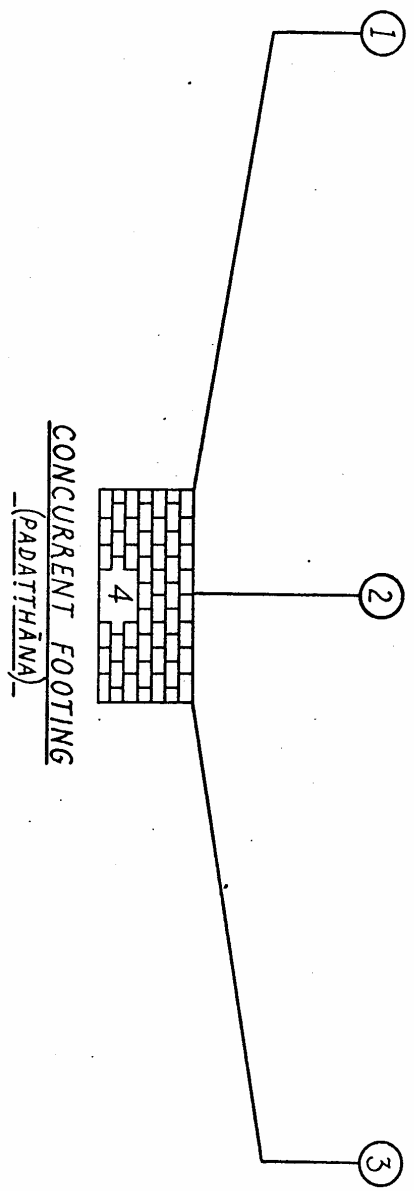

THE UNDERLYING NATURE OF THE STATE UPON
 WHICH ITS DISCERNIBLE ATTRIBUTES ARE BASED.

CHART Nº 5

REF: SCRIPT PARS. 89-93.

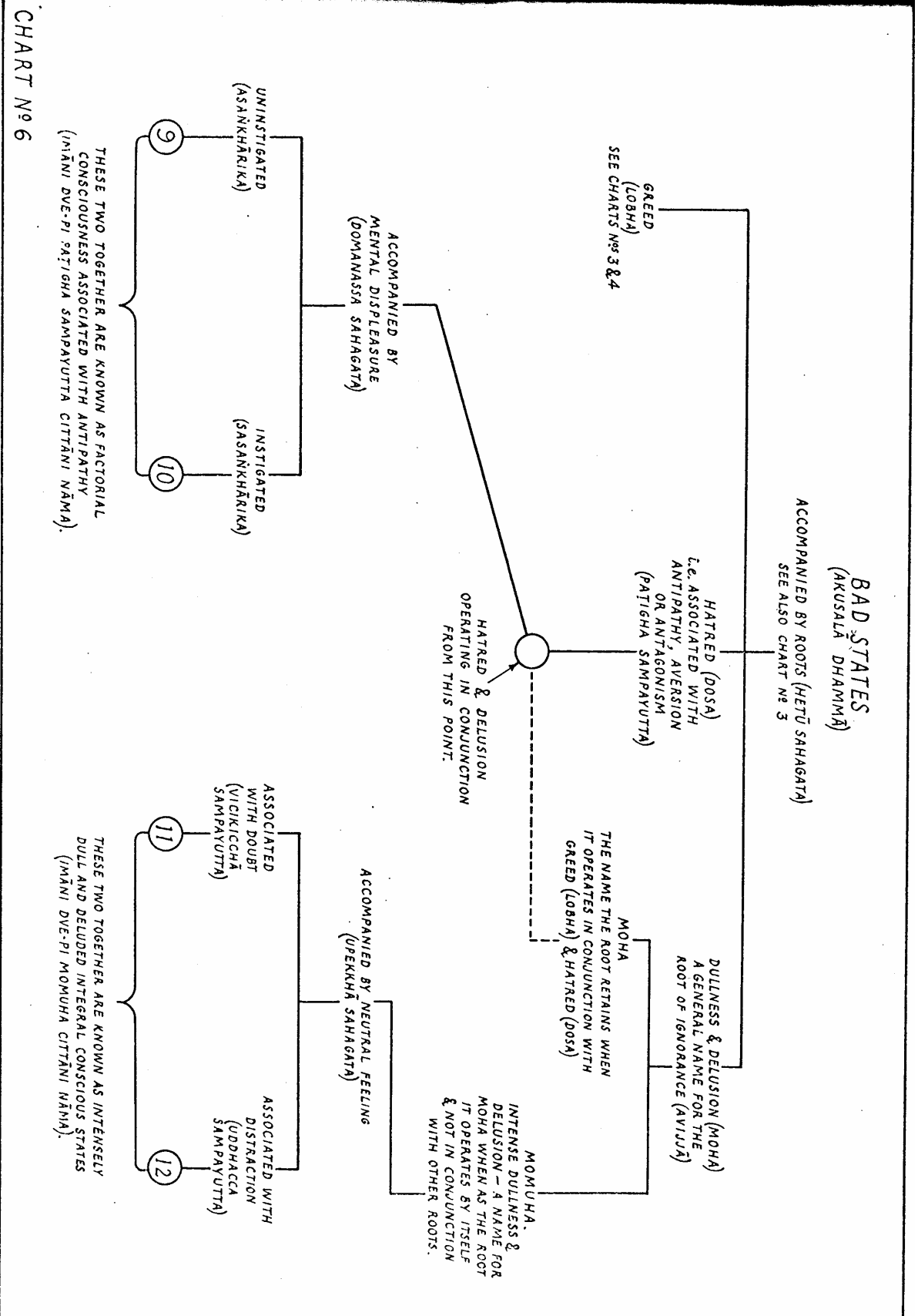
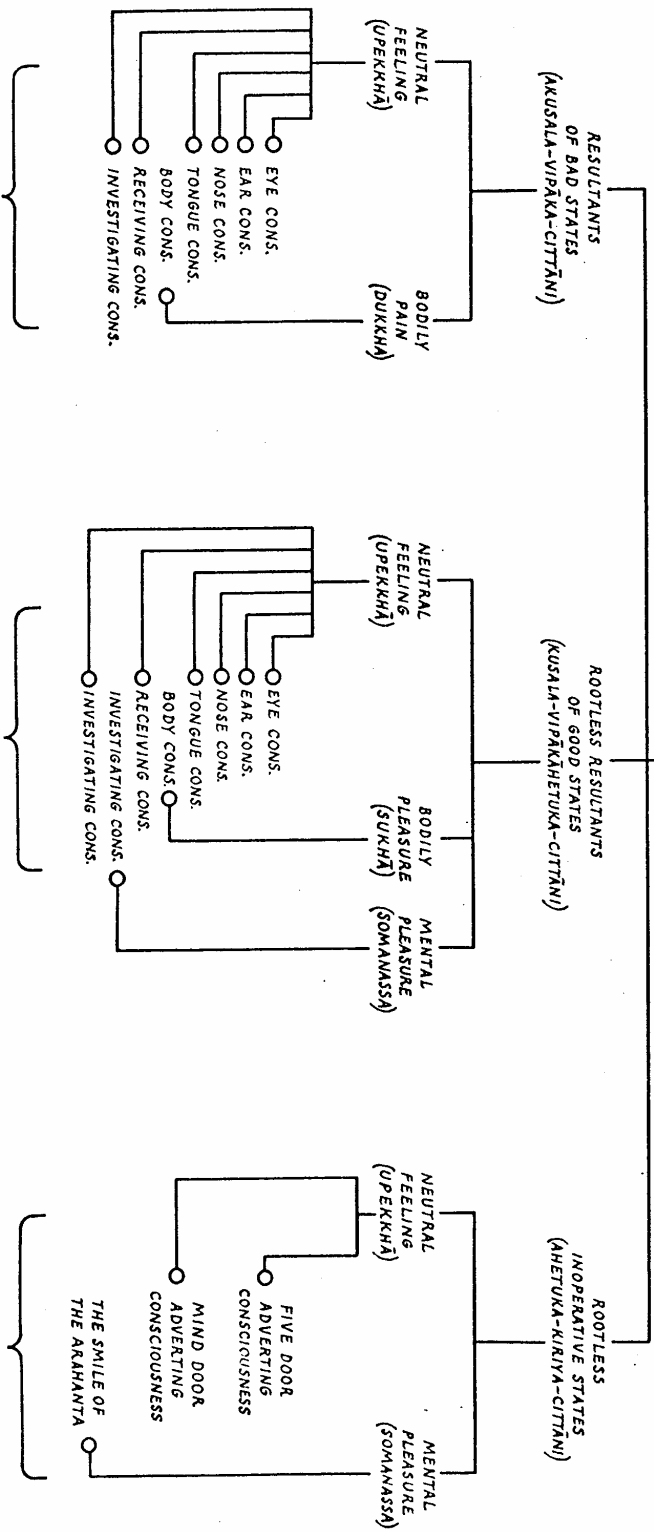

CHART N° 6

STATES WITHOUT ROOTS
(AHEṬUKĀ DHAMMĀ) SEE CHART NR 3



THESE SEVEN TOGETHER ARE KNOWN AS
INTEGRAL CONSCIOUS STATES WHICH
ARE RESULTANTS OF BAD ACTION.
IMĀNI SAṬṬĀ-PI AKUSALA-VIPĀKA-CITTĀNI NĀMA.

THESE EIGHT TOGETHER ARE KNOWN AS
ROOTLESS INTEGRAL CONSCIOUS STATES WHICH
ARE RESULTANTS OF GOOD ACTION.
IMĀNI AṬṬĀ-PI KUSALA-VIPĀKA-AHEṬUKĀ-CITTĀNI NĀMA.

THESE THREE TOGETHER ARE KNOWN AS
ROOTLESS INOPERATIVE INTEGRAL
CONSCIOUS STATES.
IMĀNI TĪṆI-PI AHEṬUKĀ-KIRIYA-CITTĀNI NĀMA.

TOTALLING 18 ROOTLESS INTEGRAL STATES

CHART NR 7.
REF: ABHIJ.S. VERSES 9,10 & 11.

24 BEAUTIFUL INTEGRAL CONSCIOUS STATES
THAT HAVE ROOTS AND ARE CHARACTERISTIC OF THE PLANE OF SENSE DESIRE

(SEE: VERSE 18)

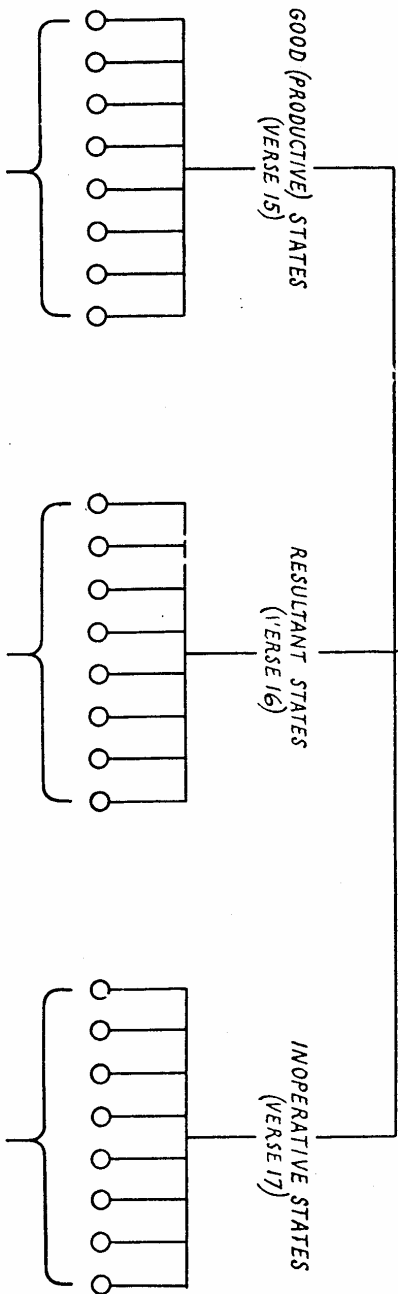

THESE EIGHT TOGETHER ARE KNOWN AS
 GOOD INTEGRAL CONSCIOUS STATES
 CHARACTERISTIC OF THE PLANE OF
 SENSE DESIRE.
 (IMĀNI AṬṬHA-PI KĀMĀVACĀRA-
 KUSALA-CITTĀNI NĀMA)

THESE EIGHT TOGETHER ARE KNOWN AS
 RESULTANT INTEGRAL CONSCIOUS STATES
 THAT HAVE ROOTS AND ARE
 CHARACTERISTIC OF THE PLANE OF
 SENSE DESIRE.
 (IMĀNI AṬṬHA-PI SAHETUKA-
 KĀMĀVACĀRA-VIPĀKA-CITTĀNI NĀMA)

THESE EIGHT TOGETHER ARE KNOWN AS
 INOPERATIVE INTEGRAL CONSCIOUS STATES
 THAT HAVE ROOTS AND ARE
 CHARACTERISTIC OF THE PLANE OF
 SENSE DESIRE.
 (IMĀNI AṬṬHA-PI SAHETUKA-
 KĀMĀVACĀRA-KIRIYA-CITTĀNI NĀMA)

(SEE ALSO CHART № 9 FOR MORE DETAILED
 STRUCTURE. THE SAME STRUCTURE APPLIES
 IDENTICALLY TO EACH OF THE THREE SECTIONS)

CHART № 8

REF: VERSES 15, 16, 17 & 18.

BEAUTIFUL INTEGRAL CONSCIOUS STATES
 CHARACTERISTIC OF THE PLANE OF SENSE DESIRE.
 SHOWING THE GENERAL ANALYSIS OF EITHER GOOD (PRODUCTIVE), RESULTANT
 OR INOPERATIVE STATES TOGETHER WITH THEIR INDIVIDUAL ROOT STRUCTURE.

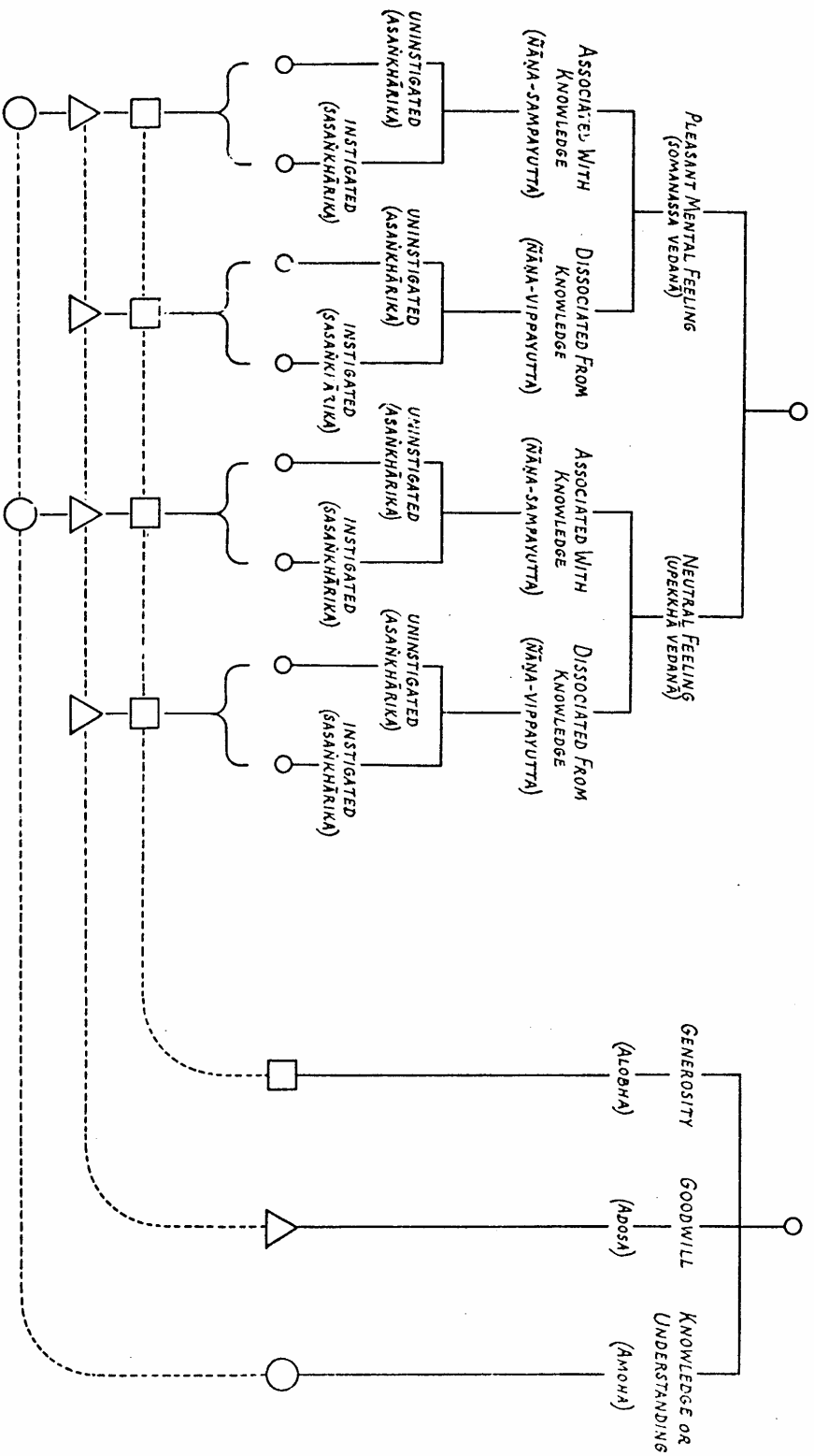

CHART No 9

TO BE READ IN CONJUNCTION WITH CHART No 8.

CONSCIOUSNESS CHARACTERISTIC OF
 THE PLANE OF FORM
 (RUPAVACARA, CITTA)
 SHOWING A GENERAL ANALYSIS OF EITHER
 GOOD (PRODUCTIVE), RESULTANT OR INOPERATIVE
 STATES, TOGETHER WITH THEIR INDIVIDUAL JHANA
 CONSTITUENTS.

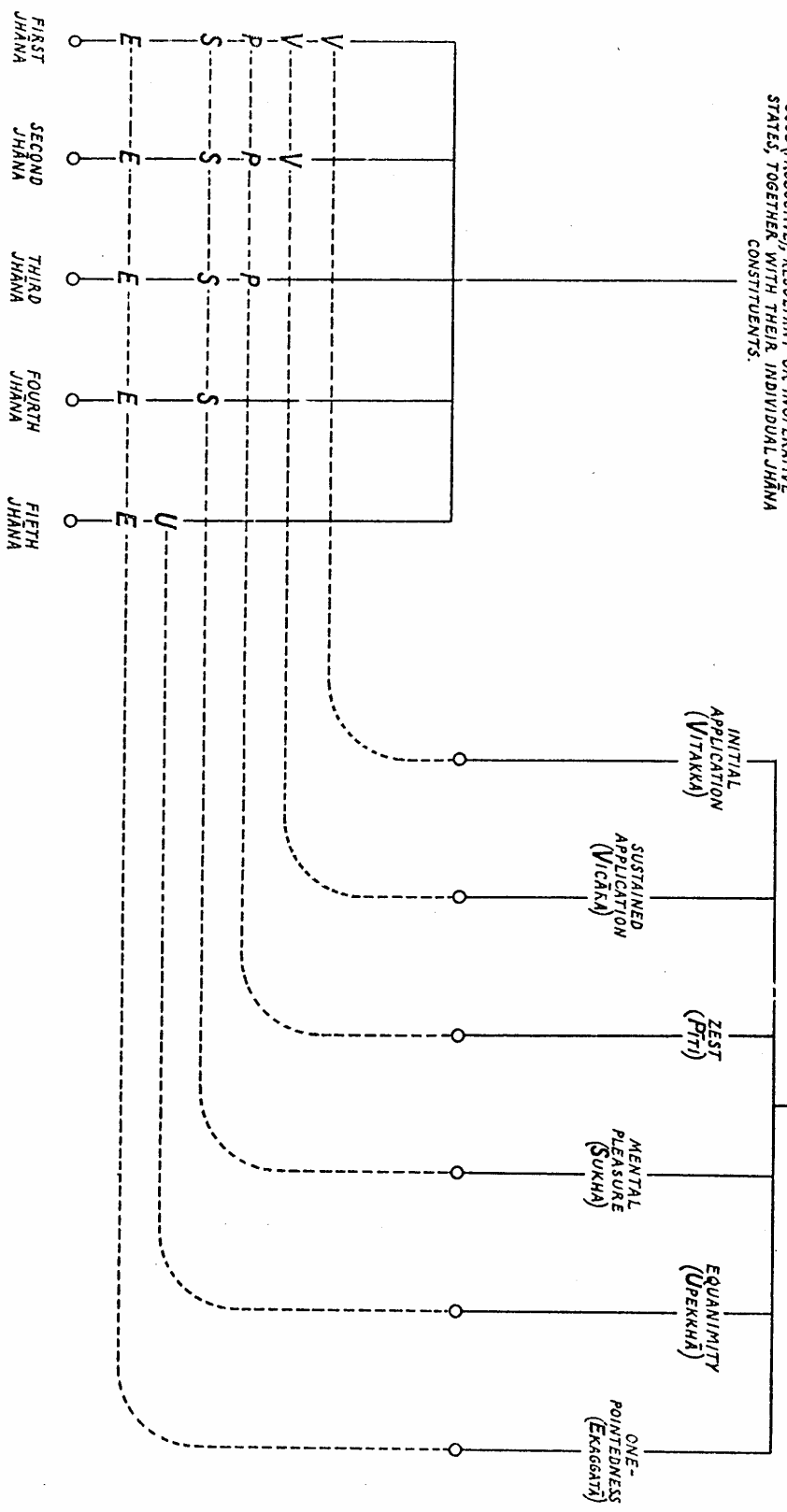

CHART No 10
 REF: ABHI/S. VERSES Nos 21-24 /INC.

HINDRANCE

1. WISH FOR SENSE PLEASURE
(KĀMACCHANDA)

IS INHIBITED BY

2. ILLWILL
(BYĀPĀDA)

IS INHIBITED BY

3. SLOTH & TORPOR —
(THINA-MIDDHA)

IS INHIBITED BY

4. DISTRACTION & REMORSE
(UDDHACCA-KUKKUCA)

5. DOUBT
(VICIKICCHĀ)

CONSTITUENT
OF JHĀNA

1. INITIAL APPLICATION
(VITAKKA)

IS INHIBITED BY

2. SUSTAINED APPLICATION
(VICĀRA)

3. ZEST
(PĪTI)

IS INHIBITED BY

4. (MENTAL) PLEASURE
(SUKHA)

5. ONE-POINTEDNESS
(EKAGGATĀ)

CHART N^o 11

ILLUSTRATING THE INHIBITING OF HINDRANCES BY
CONSTITUENTS OF JHĀNA.

CHART SHOWING THE FULL RANGE OF
RŪPĀVĀCARĀ & ARŪPĀVĀCARĀ INTEGRAL
CONSCIOUS STATES.

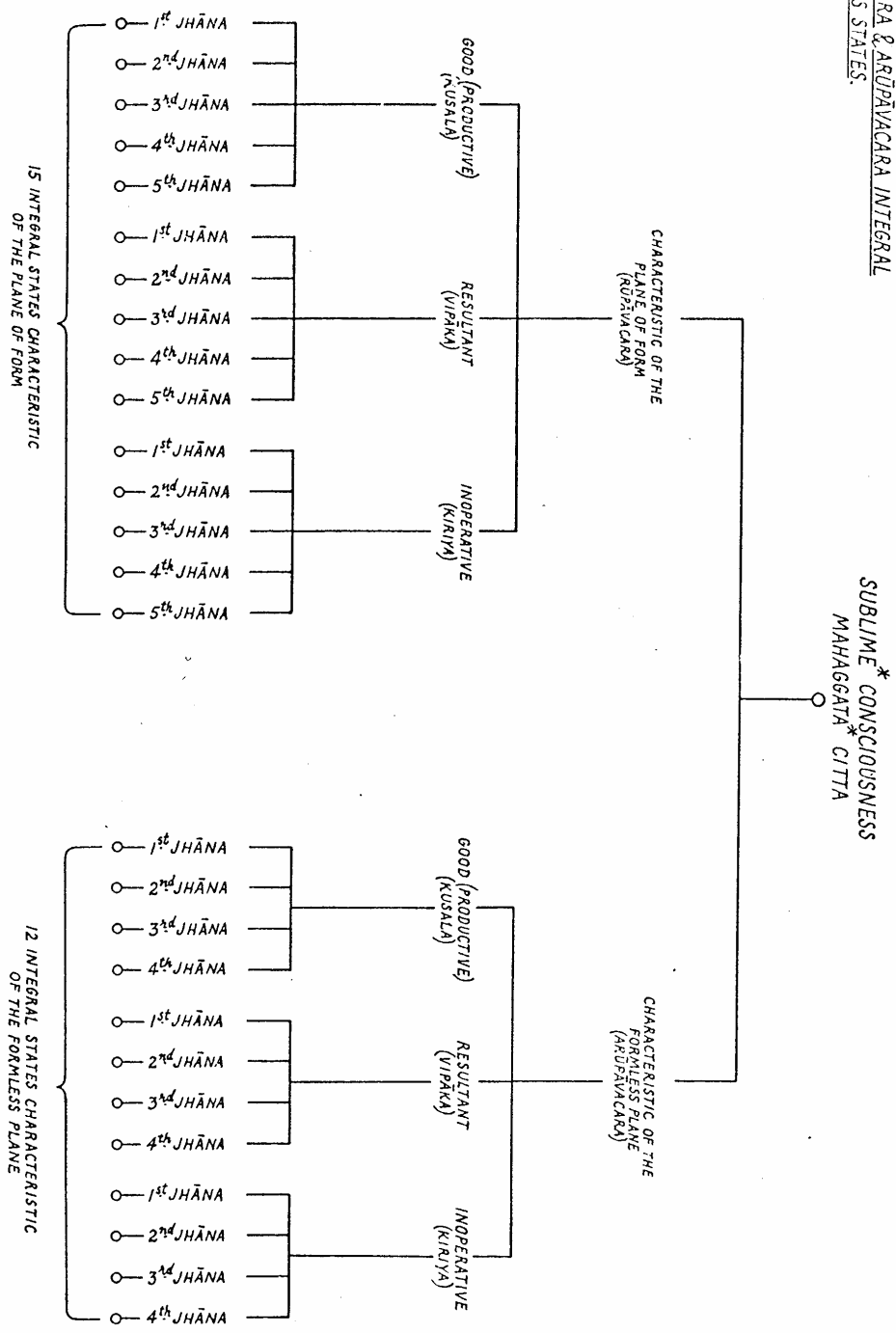

15 INTEGRAL STATES CHARACTERISTIC OF THE PLANE OF FORM

12 INTEGRAL STATES CHARACTERISTIC OF THE FORMLESS PLANE

CHART N^o 12
REF: ABHĪ'S VERSES 21-30 (INC. SCRIPT PASS. 460pp. & 480.

* THE GROUP NAME FOR THE TOTALITY OF RŪPĀVĀCARĀ & ARŪPĀVĀCARĀ INTEGRAL STATES

CHART SHOWING THE RELATIONSHIP
 BETWEEN 5th RUPAVACARA JHANA &
 THE DEVELOPMENT OF THE FOUR
 ARUPAVACARA JHANAS.

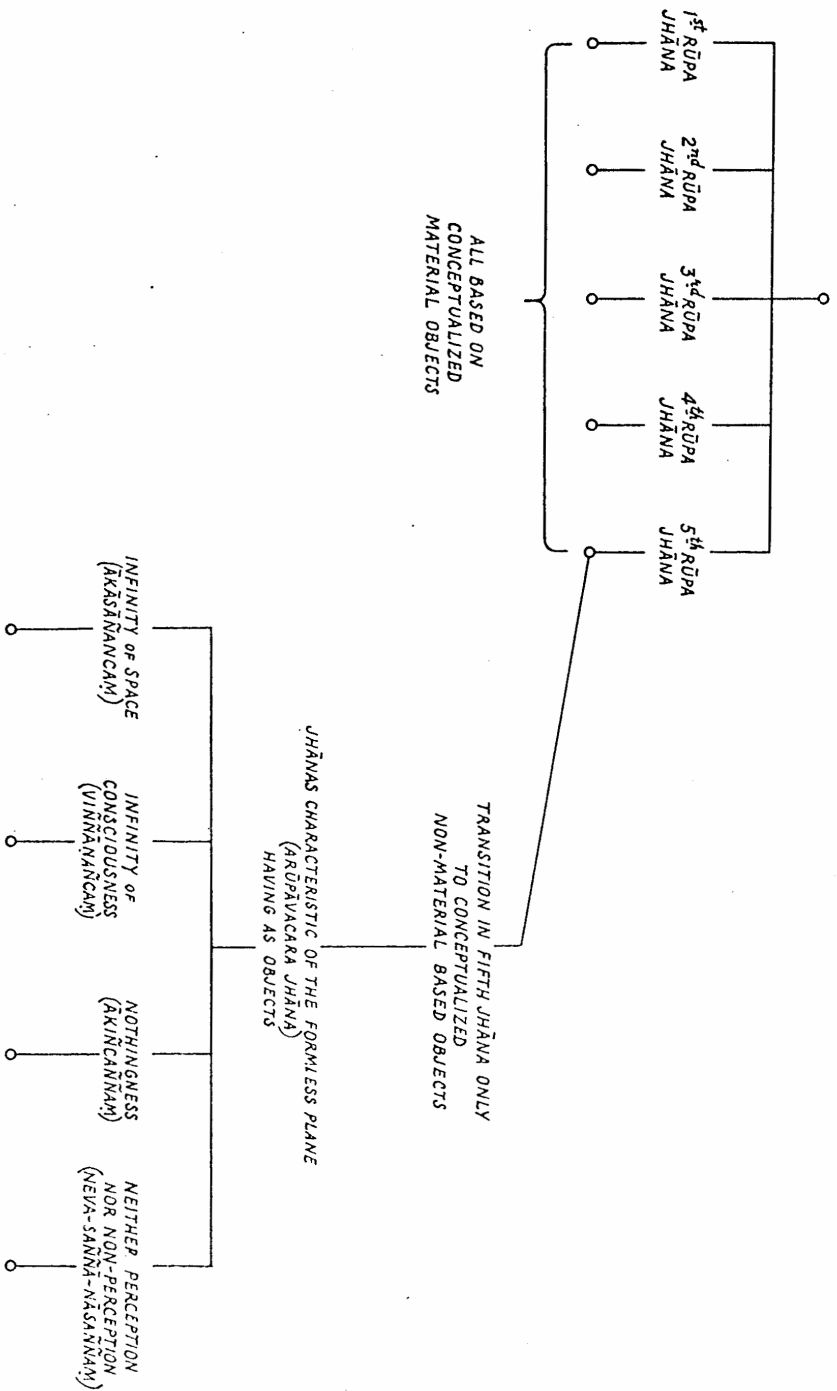

CHART No 13

REF: SCRIPT PAR. No 478

THE FOUR SUPRAMUNDANE PATHS

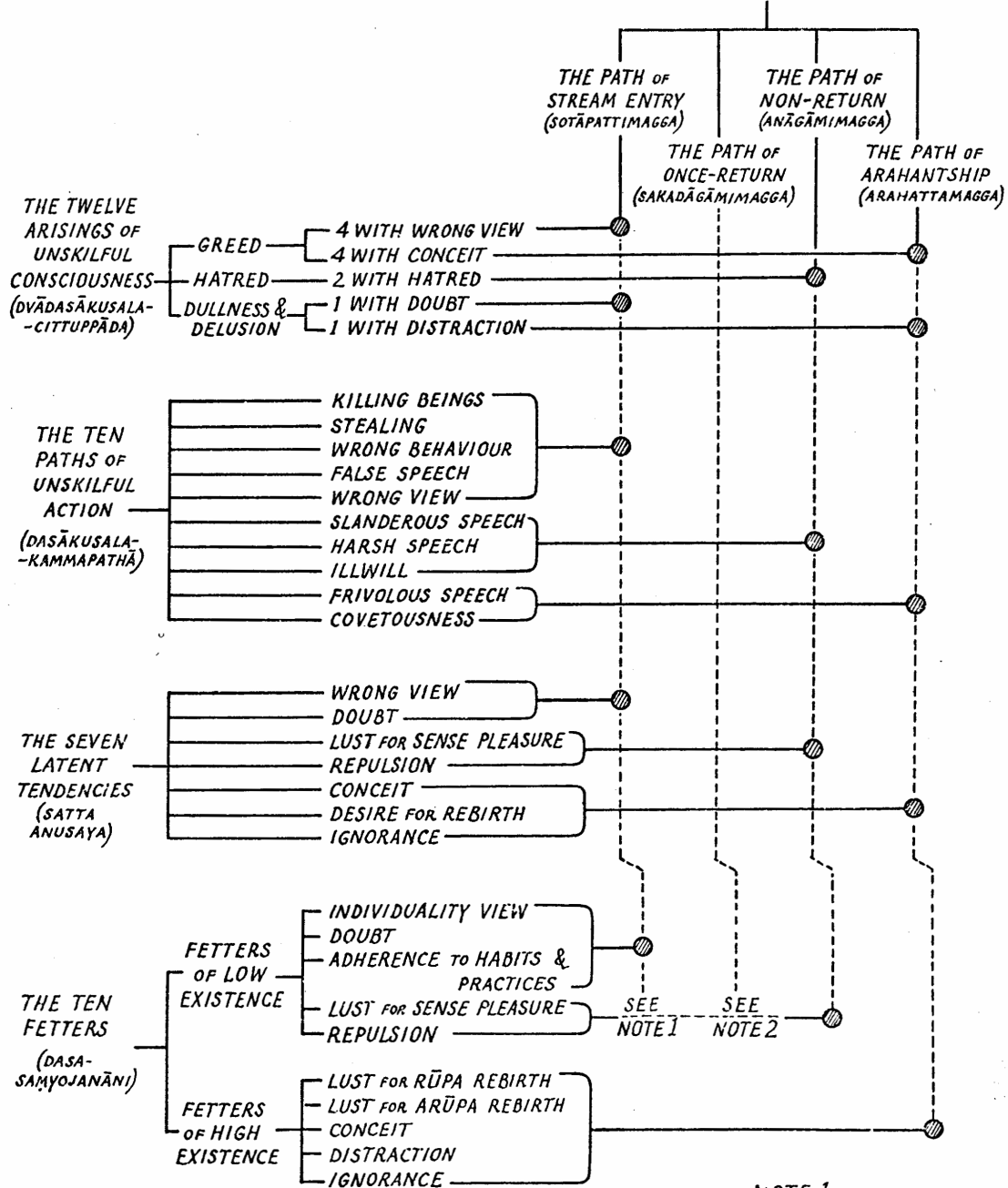

CHART N°14

THE ABANDONMENT OF INIMICAL STATES BY THE FOUR PATHS.

SEE PARS. 557-566 INC.

NOTE 1.

GROSSEST ASPECTS WEAKENED TO EXTENT THAT WOEFUL REBIRTH CANNOT BE CAUSED.

NOTE 2.

CESSATION OF GROSSEST ASPECTS.

⊗ = COMPLETE ABANDONMENT.

CHART No 15

REF: PAR. 634 B.

THE EIGHT SUPRAMUNDANE STATES (LOKUTTARA CITTA)

METHOD OF ATTAINMENT

PATH CONSCIOUSNESS (MAGGA CITTA)

FRUIT CONSCIOUSNESS (PHALA CITTA)

SIMPLE OR DRY INSIGHT (SUKKHA VIPASSANĀ)

INSIGHT OF CALM (SAMATHA VIPASSANĀ)

THESE EIGHT ARE OF A
STRUCTURE EQUIVALENT
TO 1st JHĀNA

HERE, REALIZATION OF EACH OF THE
FOUR PATHS AND THEIR APPROPRIATE
FRUITIONS IS ENTERED UPON DIRECTLY
FROM THE BASIS OF A SKILFUL KAMA-
VACARA CONSCIOUS STATE AND NOT
FROM A SINGLE BASIS OF JHĀNA. BECAUSE
OF THIS SINGLE BASIS OF REALIZA-
TION THE PATHS AND FRUITIONS
TOTAL

HERE, REALIZATION OF EACH OF
THE FOUR PATHS AND THEIR
APPROPRIATE FRUITIONS IS
ENTERED UPON DIRECTLY FROM
THE BASIS OF JHĀNA AND NOT
FROM A KAMA-VACARA STATE
THESE BEING PRECISELY EIGHT
SUPRAMUNDANE STATES BUT
FIVE JHĀNAS, EACH ABLE TO
FUNCTION AS BASES, THE
POSSIBLE COMBINATIONS OF
THE FIVE JHĀNA BASES WITH
EIGHT SUPRAMUNDANE STATES
TOTAL

- OF STREAM ENTRY
- OF ONCE RETURN
- OF NON-RETURN
- OF ARAHANTSHIP

- OF STREAM ENTRY
- OF ONCE RETURN
- OF NON-RETURN
- OF ARAHANTSHIP

8

40

- 1st 2nd 3rd 4th 5th JHĀNA PATH OF STREAM ENTRY
- 1st 2nd 3rd 4th 5th JHĀNA PATH OF ONCE RETURN
- 1st 2nd 3rd 4th 5th JHĀNA PATH OF NON-RETURN
- 1st 2nd 3rd 4th 5th JHĀNA PATH OF ARAHANTSHIP

- 1st 2nd 3rd 4th 5th JHĀNA FRUITION OF STREAM ENTRY
- 1st 2nd 3rd 4th 5th JHĀNA FRUITION OF ONCE RETURN
- 1st 2nd 3rd 4th 5th JHĀNA FRUITION OF NON-RETURN
- 1st 2nd 3rd 4th 5th JHĀNA FRUITION OF ARAHANTSHIP

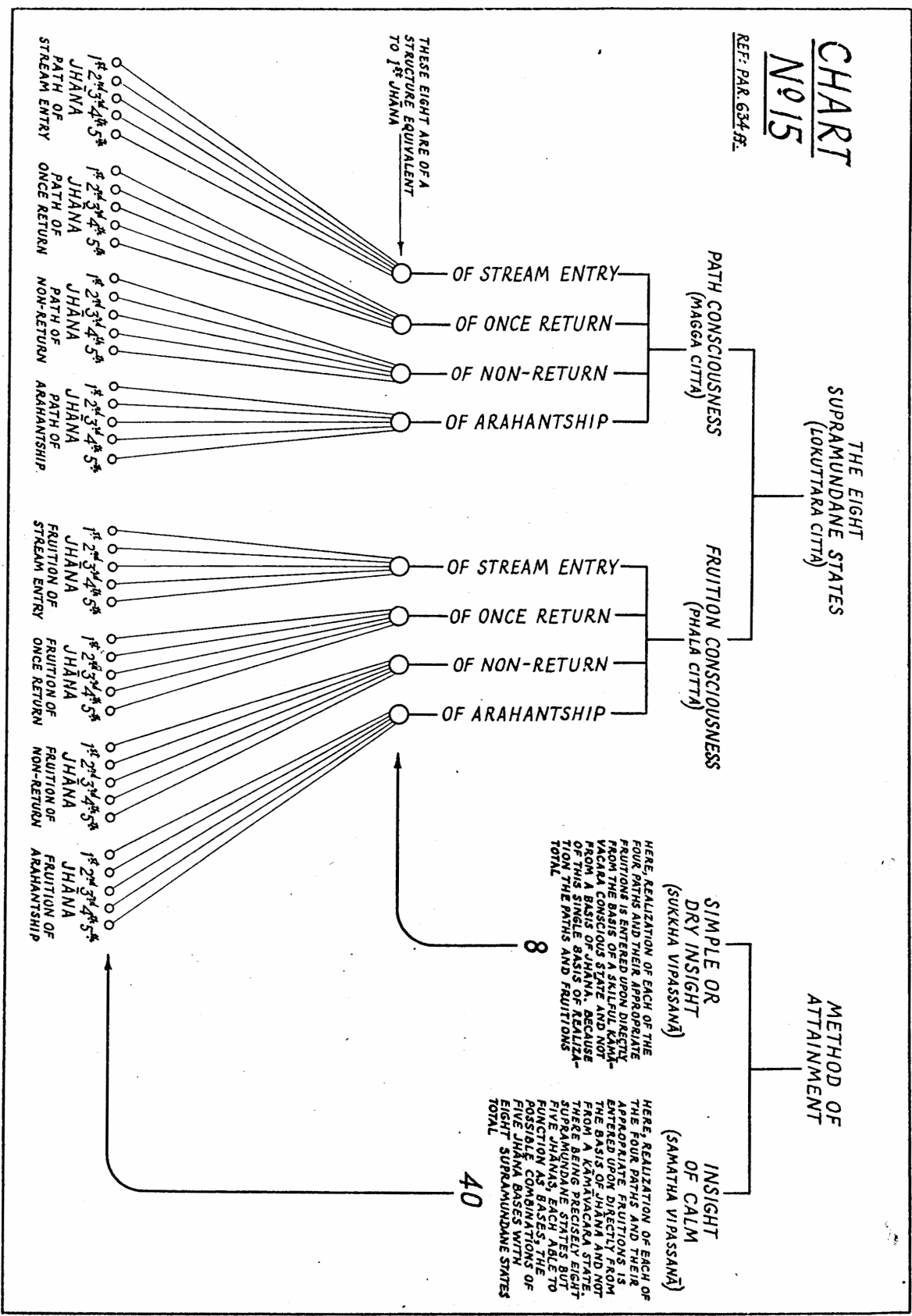

CHART No 16

THE PROCESS OF ACTIVE CONSCIOUSNESS (IN RESPECT OF A VERY STRONG SENSE IMPRESSION ONLY)

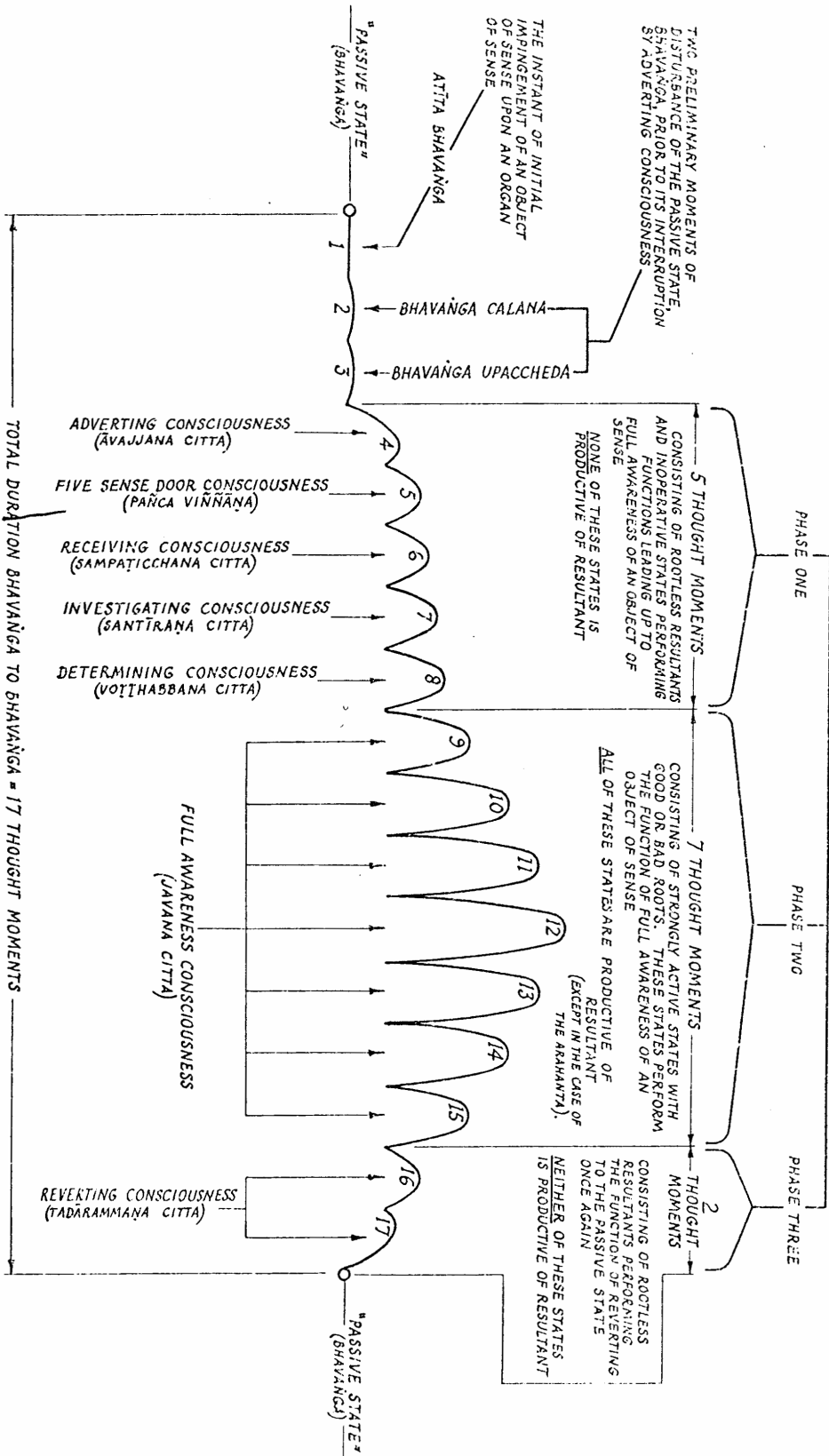
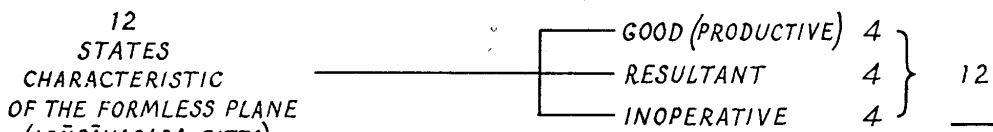
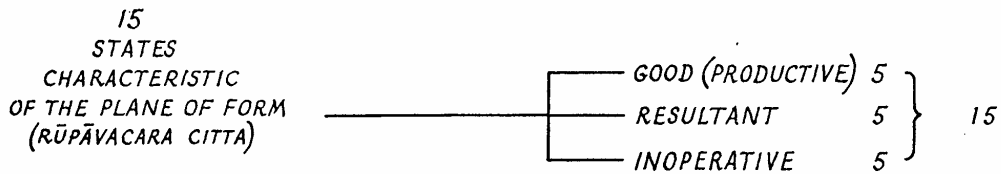
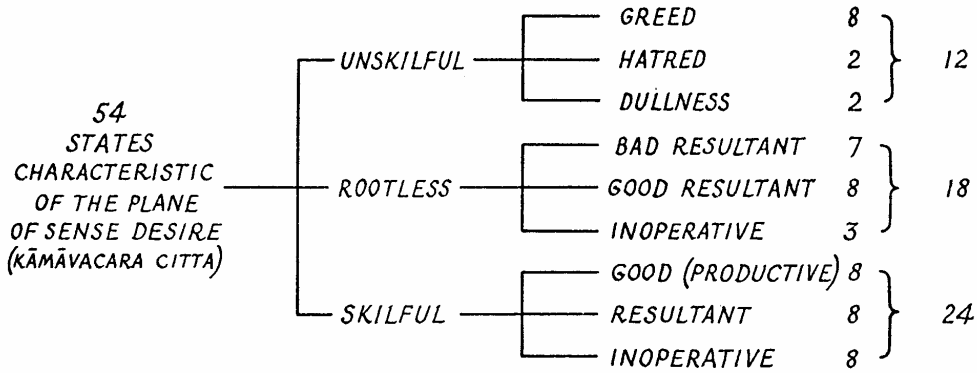

CHART N^o 17

QUICK REFERENCE CHART FOR GROUPINGS AND TOTALS OF CONSCIOUS STATES



TOTAL OF MUNDANE STATES 81

TO WHICH CAN BE ADDED

EITHER

THE PATH AND FRUITION STATES AS REALIZED WITHOUT ANY BASIS OF JHĀNA, AS IN 'DRY' INSIGHT, WHERE THE PATH AND FRUITION STATES THEMSELVES ARE NEVERTHELESS AUTOMATICALLY CHARACTERIZED BY HAVING THE STRUCTURE OF FIRST JHĀNA

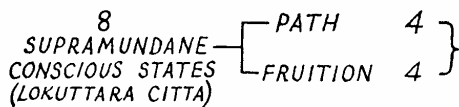

TOTAL 89

OR

THE PATH AND FRUITION STATES WHEN INITIATED FROM A BASIS OF ONE OR OTHER OF THE FIVE JHĀNAS AND ARE THUS OF APPROPRIATELY SIMILAR STRUCTURE

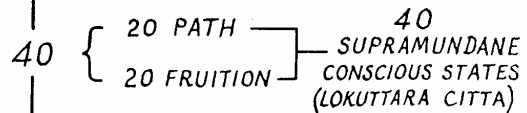

TOTAL 121